

# Needs and Opportunities for Testing of Hydropower Technology Innovations

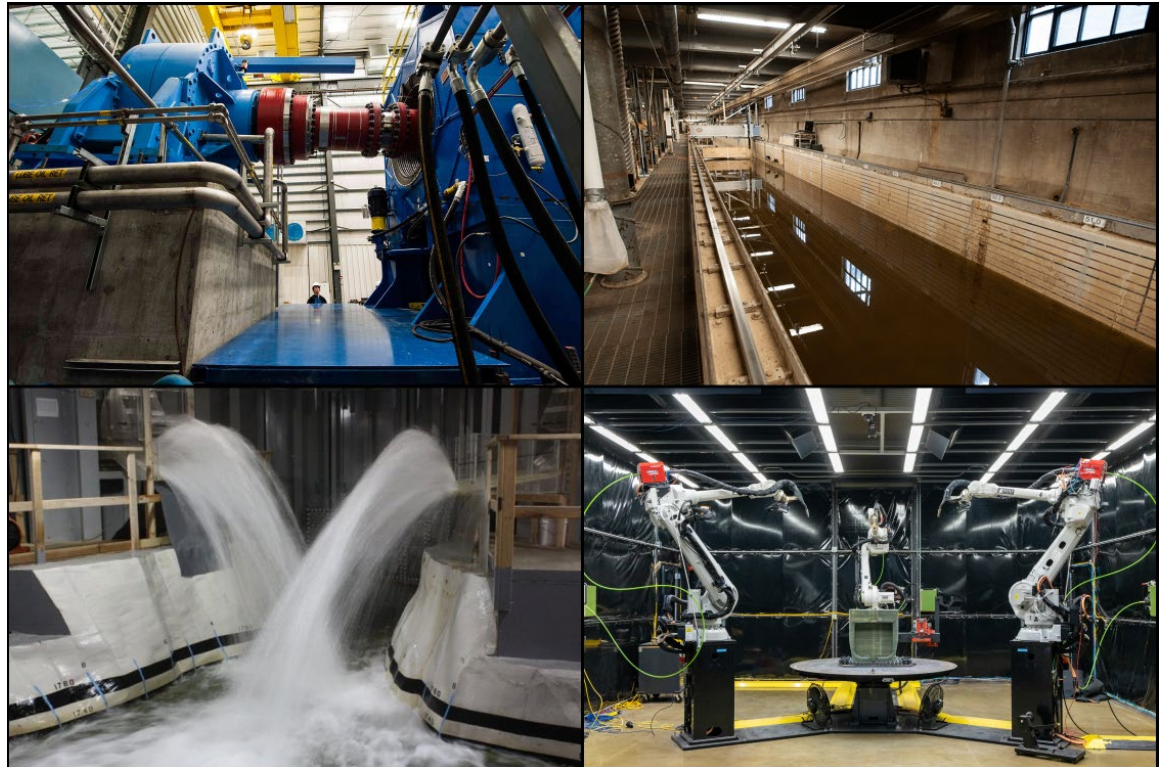

Mirko Musa  
Brennan Smith  
Colin Sasthav  
Kyle DeSomber  
Scott DeNeale  
Kevin Stewart  
et al.

**October 2022**

## DOCUMENT AVAILABILITY

Reports produced after January 1, 1996, are generally available free via OSTI.GOV.

**Website** [www.osti.gov](http://www.osti.gov)

Reports produced before January 1, 1996, may be purchased by members of the public from the following source:

National Technical Information Service  
5285 Port Royal Road  
Springfield, VA 22161  
**Telephone** 703-605-6000 (1-800-553-6847)  
**TDD** 703-487-4639  
**Fax** 703-605-6900  
**E-mail** [info@ntis.gov](mailto:info@ntis.gov)  
**Website** <http://classic.ntis.gov/>

Reports are available to DOE employees, DOE contractors, Energy Technology Data Exchange representatives, and International Nuclear Information System representatives from the following source:

Office of Scientific and Technical Information  
PO Box 62  
Oak Ridge, TN 37831  
**Telephone** 865-576-8401  
**Fax** 865-576-5728  
**E-mail** [reports@osti.gov](mailto:reports@osti.gov)  
**Website** <https://www.osti.gov/>

This report was prepared as an account of work sponsored by an agency of the United States Government. Neither the United States Government nor any agency thereof, nor any of their employees, makes any warranty, express or implied, or assumes any legal liability or responsibility for the accuracy, completeness, or usefulness of any information, apparatus, product, or process disclosed, or represents that its use would not infringe privately owned rights. Reference herein to any specific commercial product, process, or service by trade name, trademark, manufacturer, or otherwise, does not necessarily constitute or imply its endorsement, recommendation, or favoring by the United States Government or any agency thereof. The views and opinions of authors expressed herein do not necessarily state or reflect those of the United States Government or any agency thereof.

### Cover photo credits:

*Top-left:* Dynamometer Test Facility at the National Renewable Energy Laboratory's (NREL's) Flatirons Campus. The facility is used to test wind and water drivetrains with capacity ratings up to 5 MW. *Photo by Dennis Schroeder, NREL.*

*Top-right:* Main Channel Facility at the Saint Anthony Fall Laboratory (SAFL) of the University of Minnesota. *Photo by SAFL.*

*Bottom-left:* A 1:25 scale physical hydraulic model of spillways at a hydropower project, used as part of a comprehensive study to develop options for mitigation of Total Dissolved Gas at Alden Research Laboratory. *Photo by Alden Research Laboratory.*

*Bottom-right:* MedUSA at Oak Ridge National Laboratory's (ORNL's) Manufacturing Demonstration Facility. This is a large-scale hybrid system (additive, subtractive, and machining system) with three robotic arms. *Photo by ORNL.*

Environmental Sciences Division

**NEEDS AND OPPORTUNITIES FOR TESTING OF HYDROPOWER  
TECHNOLOGY INNOVATIONS**

Mirko Musa  
Brennan Smith  
Colin Sasthav  
Kyle DeSomber  
Scott DeNeale  
Kevin Stewart  
Mike Marshall  
Travis Smith  
Philip Irminger

October 2022

Prepared by  
OAK RIDGE NATIONAL LABORATORY  
Oak Ridge, TN 37831  
managed by  
UT-BATTELLE LLC  
for the  
US DEPARTMENT OF ENERGY  
under contract DE-AC05-00OR22725



## CONTENTS

LIST OF FIGURES .....	v
LIST OF TABLES .....	v
ABBREVIATIONS .....	vi
EXECUTIVE SUMMARY .....	vii
ACKNOWLEDGMENTS .....	ix
1. INTRODUCTION .....	1
1.1 PURPOSE AND OBJECTIVE .....	1
1.2 SCOPE .....	1
1.3 TESTING MOTIVATIONS AND CHALLENGES .....	3
1.3.1 The Need for Innovation in Hydropower.....	4
1.3.2 R&D Agendas Prompting Hydropower Testing.....	6
1.3.3 Sources of Testing Specifications.....	10
1.4 STRUCTURING AN ASSESSMENT OF HYDROPOWER TESTING NEEDS.....	10
2. OVERVIEW OF CURRENT AND EMERGING HYDROPOWER TECHNOLOGIES .....	13
2.1 POWERTRAIN .....	13
2.1.1 Emerging Powertrain Technologies and Testing Needs.....	14
2.2 CONVEYANCES.....	19
2.2.1 Emerging Conveyance Technologies and Testing Needs.....	20
2.3 STRUCTURE AND FOUNDATIONS .....	26
2.3.1 Emerging Structural Technologies and Testing Needs.....	27
2.4 ELECTRICAL INTERCONNECTIONS .....	28
2.4.1 Emerging Electrical Interconnections Technology and Testing Needs .....	30
2.5 I&C .....	33
2.5.1 Emerging I&C Technologies and Testing Needs .....	34
3. TESTING CHALLENGES FOR HYDROPOWER INNOVATIONS .....	39
3.1 TECHNOLOGY AND INNOVATION VALIDATION QUESTIONS .....	40
3.1.1 Powertrain Technology Example: Fish-Friendly Turbines.....	42
3.1.2 Conveyance Technology Example: Sediment Conveyance for Geomorphic Connectivity.....	45
3.1.3 Structural Technology Example: Concrete Printing for Hydraulic Structures .....	49
3.1.4 Electrical Interconnection Example: PHIL .....	51
3.1.5 I&C Example: Biomimetic Fish Sensors .....	54
3.2 THEMATIC CHALLENGES FOR TESTING HYDROPOWER INNOVATIONS.....	56
4. EXISTING TEST FACILITIES AND CAPABILITIES FOR HYDROPOWER TESTING .....	60
4.1 FACILITIES AND CLASSIFICATIONS .....	60
4.1.1 National Laboratories.....	61
4.1.2 Academic Laboratories .....	68
4.1.3 Private Research Centers and Laboratories .....	70
4.1.4 Federal Testing Facilities.....	71
4.2 MARINE ENERGY TECHNOLOGY TESTING NETWORK (TEAMER).....	74
5. OPPORTUNITIES TO ADVANCE HYDROPOWER TESTING .....	76
5.1 SUMMARY OF TESTING NEEDS AND FUTURE REQUIREMENTS .....	76
5.2 FUTURE TESTING OPPORTUNITIES.....	77
5.2.1 Initiative 1: Hydropower Testing Network Program .....	77
5.2.2 Initiative 2: Hydropower Test Facility Investment.....	78
6. THE CASE FOR LEVERAGING FEDERAL WATER INFRASTRUCTURE.....	83
6.1 OVERVIEW OF US FEDERAL INFRASTRUCTURE BY CATEGORY .....	84
6.1.1 Existing Hydropower Plants .....	86

6.1.2	Navigation Locks .....	87
6.1.3	NPDs (Non-Navigation) .....	87
6.1.4	Canals and Conduits .....	87
6.2	COST ESTIMATION .....	88
7.	REFERENCES .....	90
	APPENDIX A. OVERVIEW OF CURRENT HYDROPOWER TESTING .....	A-1
	APPENDIX B. EXAMPLE TEST FACILITY EVALUATION MATRIX .....	B-1
	APPENDIX C. SUMMARY OF RFI .....	C-1
	APPENDIX D. REVIEWER GENERAL COMMENTS AND RESPONSES .....	D-1

## LIST OF FIGURES

Figure 1. The layout and flow of rationale for this hydropower testing needs assessment. ....	2
Figure 2. TRLs.....	3
Figure 3. Histogram of NSD and NPD development potential in the United States (Hadjerioua, Wei, and Kao 2012; Kao et al. 2014) organized by (a) head and (b) $Q_{30}$ flow (watershed average 30% flow exceedance).....	5
Figure 4. The test factor testing pathways that follow from the five test factors defined in Section 1. ....	41
Figure 5. The test factor pathways of the fish-friendly turbine innovation example.....	45
Figure 6. The test factor pathways of the sediment passage innovation example. ....	49
Figure 7. The test factor pathways of the concrete printing innovation example. ....	51
Figure 8. The test factor pathways of the PHIL innovation example. ....	54
Figure 9. The test factor pathways of the biometric fish sensor innovation example.....	56
Figure 10. Map of federally owned infrastructure identified as potential candidates for testing facility retrofits. ....	86

## LIST OF TABLES

Table 1. USBR’s 2018–2022 Science and Technology Program research priorities.....	7
Table 2. Hydropower innovations compiled from Section 2. ....	40
Table 3. Validation questions, test factor combinations, and rationale for the fish-friendly turbine innovation example.....	43
Table 4. Validation questions, test factor combinations, and rationale for the sediment passage innovation example.....	46
Table 5. Validation questions, test factor combinations, and rationale for the concrete printing for hydraulic structures innovation example. ....	50
Table 6. Validation questions, test factor combinations, and rationale for a PHIL innovation pathway.....	52
Table 7. Validation questions, test factor combinations, and rationale for the biomimetic fish sensors innovation example. ....	55
Table 8. Examples of existing hydropower testing capabilities at US national laboratories spanning the five physical design categories of the hydropower technological landscape .....	63
Table 9. Average hydraulic head and flow operating ranges of emerging small hydropower turbines.....	80
Table 10. Criteria used for high-level filtering analysis of potential federal infrastructure candidates.....	85
Table 11. Empirical equations and coefficients used for cost estimation adapted from the 2015 Hydropower Baseline Cost Model Report (O’Connor, Zhang, et al. 2015). ....	89
Table 12. High-level cost estimates for retrofitting hydropower testing capabilities on existing infrastructure.....	89

## ABBREVIATIONS

AC	alternating current
CEATI	Center for Energy Advancement through Technological Innovation
CHIL	control hardware in the loop
DC	direct current
DER	distributed energy resource
DOE	US Department of Energy
ECF	efficiency, capacity, and flexibility
EI	environmental interactions
EPRI	Electric Power Research Institute
EPS	electrical power system
ERDC	Engineer Research and Development Center
H&S	health and safety
I&C	instrumentation and control
INL	Idaho National Laboratory
IP	intellectual property
MRE	marine renewable energy
NHA	National Hydropower Association
NPD	non-powered dam
NREL	National Renewable Energy Laboratory
NSD	new stream-reach development
ORNL	Oak Ridge National Laboratory
OEM	original equipment manufacturer
PHIL	power hardware in the loop
PNNL	Pacific Northwest National Laboratory
RFI	Request for Information
RRM	reliability, resilience, and maintainability
SNL	Sandia National Laboratories
TRL	technology readiness level
TVA	Tennessee Valley Authority
USACE	US Army Corps of Engineers
USBR	US Bureau of Reclamation
WPTO	Water Power Technologies Office



## EXECUTIVE SUMMARY

Despite hydropower's status as a well-established technology, changes in the global energy sector have prompted a variety of necessary hydropower technological innovations. Examples include efficient low-head turbines, more flexible and dispatchable hydropower and pumped storage systems to complement variable and intermittent renewable resources, and technologies providing higher environmental performance. However, while innovative technologies are currently being proposed to meet these development challenges, small hydropower facility owners do not have sufficient risk-bearing capacity to adopt new, unvalidated technologies. This discourages manufacturers from bringing nascent technologies to market and stalls the technological growth of the sector. To reduce the risks associated with new technologies and promote further innovation, systemic (and sometimes unconventional) validation activities and new testing capabilities for hydropower are highly desired. These testing capabilities must demonstrate the safety, environmental acceptability, reliability, and performance of innovative technologies to quantify their value compared with existing technologies. Establishing these capabilities through dedicated testing facilities will be key to promoting hydropower growth in the United States.

Following direction from the House Energy and Water Development Committee, the US Department of Energy's Water Power Technologies Office (WPTO) has been tasked with understanding the state of hydropower testing in the United States. This scoping report discusses the needs and opportunities of hydropower testing in the United States, with a specific focus on small hydropower. Future developments will likely mostly target low-head sites with less than 30 ft (9.1 m) from new stream-reach developments, non-powered dam retrofits, and rehabilitation/upgrade of existing plants.

Based on emerging technology trends, testing gaps evaluation, and stakeholder inputs, four overarching thematic challenges were identified for testing hydropower innovations:

- **Theme 1:** Full-scale testing is necessary to validate small hydropower innovations.
- **Theme 2:** Validation of environmental mitigation technology innovations is crucial and will benefit from a coordinated community effort.
- **Theme 3:** Hydropower technologies must be tested and validated for flexible operations over extended durations to ensure hydropower's value in the evolving grid.
- **Theme 4:** Advanced materials and manufacturing for hydropower components will require new and updated testing and validation procedures to enable innovative designs.

Existing capabilities for hydropower technology testing can be found at national laboratories, universities, private testing centers, and federal agencies. Most of these capabilities can already cover several hydropower testing needs at model scale, or at full scale on isolated components of specific design categories (e.g., powertrains). However, few or no locations have testing technologies at full scale for high-technology readiness level innovations that involve high hydraulic capacity.

Based on the findings highlighted in the report, two complementary initiatives have been identified as the most promising to support hydropower innovation through technological testing:

- **Initiative 1: Hydropower testing network program.** To reduce the cost barrier, a government-sponsored testing network program may support technological validations by coordinating existing hydropower testing capabilities highlighted in this report (at national laboratories, universities, private testing centers, and federal agencies) and providing initial support for testing activities. The program may leverage the structure and experience from other successful industrial support mechanisms, such

as the WPTO TEAMER (Testing and Expertise for Marine Energy) network for marine energy technology development.<sup>1</sup>

- **Initiative 2: Hydropower test facility investment.** Governmental support could be devoted to the development of additional testing infrastructure to pursue designs validation at full-scale, flow-through conditions, and with capabilities to monitor transient and dynamic responses for sustained durations. The facilities should be able to support validation of environmental metrics and unconventional material and manufacturing techniques.

The desired characteristics (or criteria) for a full-scale testing facility can be inferred from hydropower development trends and the testing thematic challenges:

- **Head capability.** The facility should target a flexible head operating range with max capability of at least 30 ft (9.1 m).
- **Flow capability.** The facility should target a maximum flow capability ranging between 1,000 and 3,000 cfs (28 and 85 m<sup>3</sup>/s), and larger flow capabilities are preferred.
- **Testing duration and availability.** The facility should be accessible for several testing durations, ranging between short-term (days to weeks) and long-term (months) needs.
- **Diversity of testing objectives and capabilities.** The facility should be able to validate as many design objectives as possible beyond power generation. The facility should also accommodate validation of environmental mitigation technologies and structures made with unconventional materials and manufacturing processes.
- **Accessibility and regionality.** The facility should be easily accessible and available for testing year-round, and it might be preferably located in regions with high hydropower development and/or development potential.
- **Regulatory and operational impact.** The facility should meet federal, state, and local licensing requirements, minimize the environmental impacts, and avoid/minimize negative impacts on the operation of potentially existing infrastructure.
- **Cost effectiveness.** The facility should use the lowest-cost alternatives to meet the performance goals of the project, potentially incorporating revenues from energy generation from powertrain testing or parallel operations.

These criteria are desired features for a potential full-scale testing facility and are mostly intended to be general guidance for any future initiative. A single facility might not be able to fulfill all the criteria at once, so various factors might be prioritized, and ranges of compatibility could be proposed.

Some existing federal water infrastructure may be retrofitted to provide testing support with the following advantages: full-scale testing, reduced regulatory burden associated with new infrastructure development, centralized resources to execute testing, and support from the federal government. However, the retrofit must not interfere with the existing facility's purpose. Opportunities can be found at decommissioned hydropower facilities, navigations locks, non-powered dams, canals, and conduits.

---

<sup>1</sup> <https://www.teamer-us.org/>

## ACKNOWLEDGMENTS

### US Department of Energy Water Power Technologies Office

The authors would like to acknowledge and express their appreciation to the US Department of Energy's (DOE's) Water Power Technologies Office (WPTO) for overseeing and funding this scoping study to assess needs and opportunities for testing hydropower technology innovations. The following DOE WPTO staff were heavily involved in reviewing this report and supporting this study:

- Madden Sciubba
- Timothy Welch
- Jennifer Garson

### Oak Ridge National Laboratory

The following individuals from DOE's Oak Ridge National Laboratory provided technical editing, review, and support for this report:

- Olivia Shafer
- Shih-Chieh Kao
- Christopher DeRolph

### Technical Reviewers

The following individuals provided a thorough technical review of this report as external critical reviewers. The listing of reviewers does not imply their agreement with all findings of the report.

- Clark Bishop, US Bureau of Reclamation
- Lucas DeLong, Kleinschmidt Associates, Chair of the IEEE PES EDPG Hydroelectric Power Subcommittee
- Budi Gunawan, Sandia National Laboratories
- T. J. Heibel, Pacific Northwest National Laboratory
- Curt Jawdy, Tennessee Valley Authority
- Vladimir Koritarov, Argonne National Laboratory
- Al LiVecchi, National Renewable Energy Laboratory
- Pradeep Ramuhalli, Oak Ridge National Laboratory
- Stephen J. Reese, Idaho National Laboratory

### Request for Information Respondents

The following organizations or individuals provided written response to Request for Information DE-FOA-0002561, issued August 24, 2021. The listing of respondents does not imply their agreement with all findings of the report. More details regarding the request for information are provided in the appendix.

- Alden Research Laboratory
- Cadens LLC
- Hydropower Foundation
- Mark McKinley
- Natel Energy

- National Hydropower Association
- Pacific Northwest National Laboratory
- St. Anthony Falls Laboratory (University of Minnesota)
- Tennessee Valley Authority
- Tetramer Technologies LLC
- University of California, Davis
- US Army Corps of Engineers, Engineer Research and Development Center
- Willow Springs Water Bank

### **DOE National Laboratories**

The following DOE national laboratories provided specific input on their testing facilities and capabilities:

- Argonne National Laboratory
- Idaho National Laboratory
- National Renewable Energy Laboratory
- Pacific Northwest National Laboratory
- Sandia National Laboratories

### **Federal Agencies**

The following federal agencies provided specific insight on their hydropower facilities and guidance on potential future opportunities for hydropower testing development:

- US Army Corps of Engineers
- US Bureau of Reclamation

In addition, the authors would like to acknowledge that this scoping study report provides a first-of-its-kind assessment of the testing needs and capabilities for hydropower technology innovation in the United States. Additional insights may be gained through additional stakeholder input. The authors would like to thank the many labs, universities, and contributors who made this report possible, and the authors look forward to future insights and collaboration to improve upon the information collected.

# 1. INTRODUCTION

## 1.1 PURPOSE AND OBJECTIVE

Because of the strategic importance of hydropower in the national renewable energy portfolio, the House Energy and Water Development Committee of the Congress of the United States, starting in FY 2020 and continuing throughout FY 2023, “remains supportive of the Department’s [DOE’s] ongoing scoping activities toward establishing a network of hydropower testing facilities” (US House Energy and Water Development Committee 2022). To support DOE’s Water Power Technologies Office (WPTO) responding to this congressional inquiry, Oak Ridge National Laboratory (ORNL) was directed by WPTO to prepare this scoping report to better understand the role of testing facilities and capabilities in the current and future research, development, demonstration, and deployment of innovative hydropower technology. As the United States moves toward a more sustainable electric power system, the hydropower development context and the associated opportunities for innovation have changed significantly and will continue to change over time. New hydropower development will be at sites with lower heads and flows than much of hydropower developed in the twentieth century. Existing hydropower facilities can also benefit from technological innovations that improve flexibility, sustainability, and reliability without prohibitive cost increases. These innovations will require validation through testing if they are to garner investment for development and progress to commercialization and wide-ranging deployment.

The objective of this report is to clarify the immediate needs for investment in hydropower innovation testing facilities and capabilities. This testing must enable hydropower technology innovators to advance their technologies through validation so that the necessary conditions are met for investment in and adoption of these technologies at commercial scale. Using this report, WPTO may consider these immediate needs as it prioritizes testing within its research, development, and demonstration programming. More specifically, the reports objectives are to (1) distinguish between testing that is already accomplished well within the hydropower industry and testing for which capabilities are absent; (2) identify barriers that prevent technology innovators from accessing existing testing facilities and capabilities; and (3) identify resources—including the potential for repurposing or co-purposing mission-specific federal water infrastructure—that may be helpful in making existing and new testing facilities/capabilities available to hydropower technology innovators. To accomplish these objectives, a review of literature, a public request for information (RFI), and a nationwide analysis of existing facilities were conducted. Ultimately, the report reflects and summarizes feedback from hydropower stakeholders (e.g., developers, owners, researchers), who are therefore contributors and beneficiaries.

## 1.2 SCOPE

A simple definition of *testing* is to measure the quality, performance, or reliability of a technology, especially before putting it into widespread use or practice. A broader interpretation of testing in its application to hydropower includes assessing the effects of technology on public and worker health and safety, and interactions of technology with biota, proximate equipment and property, and other components of the environment. The focus of this report is *innovation testing for hydropower technology*—testing that occurs within R&D to validate a technological innovation before putting it into the market. Innovation testing is crucial to commercialization and deployment because it helps satisfy the technical, economic, and environmental performance standards of R&D investors, first adopters, natural resource stewardship agencies, and other stakeholders. Thus, throughout this report, *testing* should be assumed to refer to the following definition:

***Hydropower technology innovation testing:*** *an activity that validates the health and safety protections, quality, performance, reliability, resilience, maintainability, or*

*environmental interactions of hydropower technological and methodological innovation prior to, and in furtherance of, commercialization and widespread adoption.*

Innovation testing is distinct from production testing, which occurs for routine assessment of commercialized equipment for production quality, functional degradation after normal use, damage and operational status after an extreme or catastrophic event, and quality of repairs. Similar physics, apparatuses, and methods may be involved in innovation testing and production testing, but the purpose, utility, and cost of these two realms are different. Production testing usually entails standardized methodologies and equipment and minimal cost per unit tested to ensure that a threshold of performance is met, whereas innovation testing typically entails more varied conditions, experimental methodologies, specialized equipment, and greater costs to explore the response and performance of technological innovations and prototypes under multiple use scenarios and ambient conditions. Innovation testing and production testing intersect when technological innovation creates the potential for new production testing technology or methodology that reduces testing costs, reduces the cost of operating hydropower assets, or increases the production or services available from a hydropower asset.

Figure 1 highlights the structure of this scoping study.

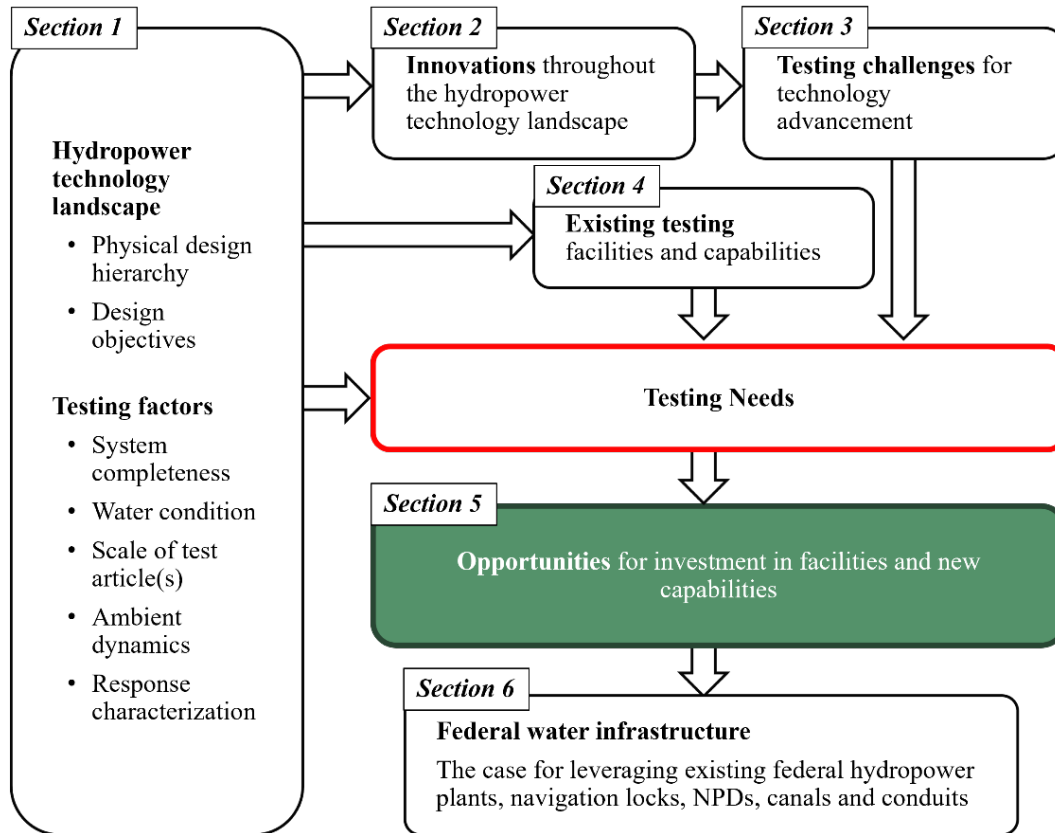

**Figure 1. The layout and flow of rationale for this hydropower testing needs assessment.**

Section 1 introduces motivations and challenges of hydropower testing and proposes an overview of the hydropower technology landscape (i.e., the hierarchy of hydropower technology and its design objectives) and the test factors (i.e., intrinsic characteristics of the testing activities). Section 2 provides an overview of current technologies and discusses emerging technologies and needs for validation for each category of the physical design hierarchy, with references to the standards and requirements engendered by the design objectives. Section 3 describes the testing challenges for emerging technology and how the

aforementioned test factors are invoked by the design objectives for each validation. Section 4 summarizes the testing facilities and capabilities existing in the United States (without aiming to be comprehensive) that are or could be applied to these testing challenges. Section 5 explores opportunities for investment in new testing facilities and capabilities as a result of the scoping study. Finally, Section 6 provides an overview of existing federal water infrastructure and proposes their potential repurposing as full-scale hydropower testing facilities.

### 1.3 TESTING MOTIVATIONS AND CHALLENGES

Testing is necessary to advance a hydropower technology innovation along the path from conception to commercialization. Inventors and innovators, whether they are individuals or companies, create value by translating their innovative ideas into prototypes that must be tested, refined, and retested until they become deployment-ready technologies. A common framework for describing this innovation process is through technology readiness levels (TRLs), which are typically represented on a scale from 1 to 9. Each TRL represents a step closer to the end goal of field deployment, as shown in Figure 2.

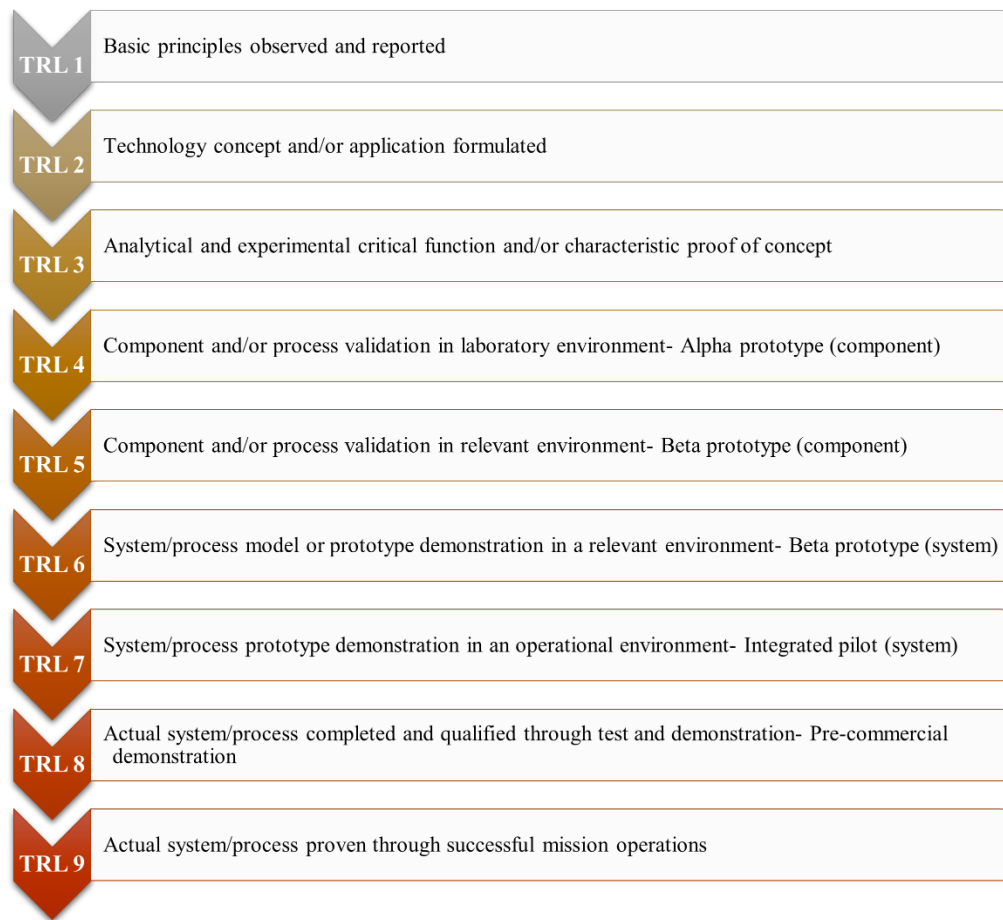

**Figure 2. TRLs.**

The steps can differ among technologies, but they can include validation of concepts through computer models, partial-scale physical testing of prototypes, and full-scale physical testing of pilot projects. Testing provides several functions, including benchmarking technology performance and identifying areas for improvement, ensuring operation and performance over a wide range of conditions, and alleviating risks of the technology for stakeholders. Innovations often inherently carry a risk, whether that is a physical risk to human safety or equipment or an economic risk for the loss of investment. Testing

provides a track record to describe qualitatively and quantitatively the risk of failure and the value of the technology. Several stakeholders must decide whether the value of the innovation outweighs the risk, including the following:

- Investors, who provide funding for research, development, prototyping, scale-up, and initial production
- First adopters, who incur costs of acquisition, installation, operation, maintenance, forced outage, risk and consequences of failure, and decommissioning of first-generation units
- Regulatory and resource authorities (and their constituencies), who are concerned with potentially adverse environmental interactions of new technologies, or failure of environmental protection
- Insurers, who underwrite projects and provide compensation in the case of project failures

### **1.3.1 The Need for Innovation in Hydropower**

Innovation drives the need for testing, so it is important to highlight why a demand for innovation in hydropower exists. Technological innovation can lower costs, improve performance, and expand the opportunities for hydropower in the United States. As described in the DOE Hydropower Vision Report (US Department of Energy 2016), hydropower growth can come in many forms, including upgrades to existing plants, retrofits of non-powered dams (NPDs), new stream-reach development (NSD) projects, pumped storage hydropower, and innovative hydropower configurations. Growing electricity demands and clean electricity goals across state and federal levels provide clear motivations for growth in the hydropower sector, but the need for innovation, as opposed to expansion of conventional technologies, stems from several trends (US Department of Energy 2016).

First, the focus on available hydropower potential has shifted from high-head projects to small, low-head projects. This is exemplified in the NSD and NPD resource assessments conducted at ORNL, as illustrated in Figure 3 (Hadjerious, Wei, and Kao 2012; Kao et al. 2014). The figure highlights that the majority (71%) of hydropower potential is contained within low-head sites (<30 ft, or 9.1 m, of head). Lower-head sites are considered to have higher costs per kilowatt on average, so innovation is needed to lower costs (O'Connor, DeNeale, et al. 2015). When cost reduction is the goal of innovation, performance and reliability testing is imperative to monitor the cost/benefit trade-offs. For example, using additive manufacturing techniques for runner blades may reduce initial costs but may lead to lower durability, which would require higher maintenance costs. These trade-offs exist throughout all classes of hydropower technologies.

The second trend is aging dam infrastructure. Most dams are reaching the end of their expected 50–100 year lifetimes in the next 2 decades, meaning that dam owners face difficult decisions about whether to rehabilitate, retrofit, or remove their projects (Stanford University Uncommon Dialogue 2020; DeNeale et al. 2019; Hansen et al. 2021). The economic and environmental costs of each of these options can be significant. Innovations in technologies for retrofit or rehabilitation could improve the value proposition of adding NPD infrastructure to the hydropower fleet. Civil works necessary for the retrofit might be a serious challenge and structural safety will be a major concern, so innovative modular designs, advanced manufacturing, and alternative materials are needed to safely integrate new technologies and rehabilitate existing infrastructure. These innovations will require testing for the reliability/stability of the technology and the existing infrastructure. In addition, new technologies may require new ways to deploy the technology, which requires testing for the health and safety of people during deployment.



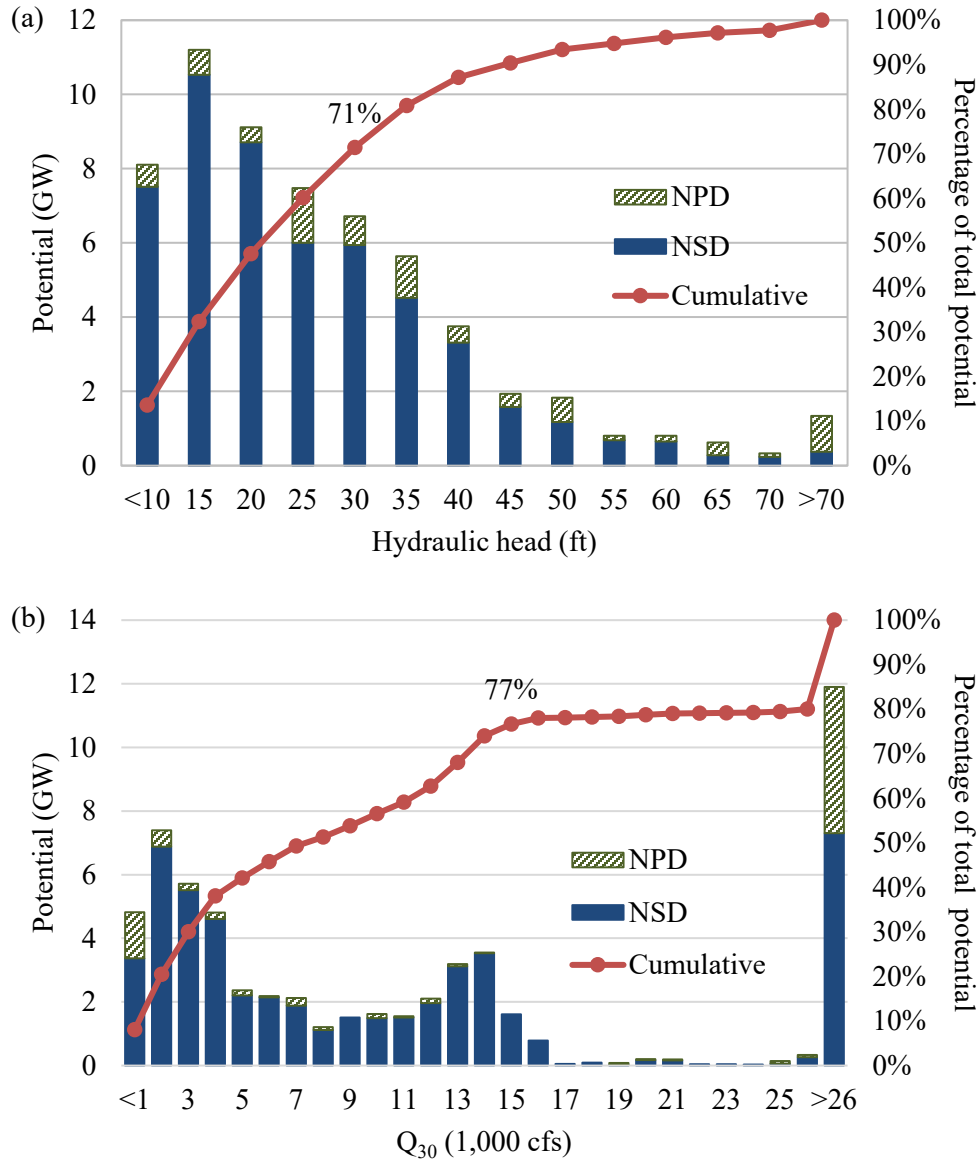

**Figure 3. Histogram of NSD and NPD development potential in the United States (Hadjerioua, Wei, and Kao 2012; Kao et al. 2014) organized by (a) head and (b) Q<sub>30</sub> flow (watershed average 30% flow exceedance). Only includes sites with >1 MW of potential capacity and available flow and head data. The red dotted lines indicate the percentage of total cumulative potential (i.e., 59.7 GW total: 51.5 GW of NSD and 8.2 GW of NPD) for a given head or flow. The data labels highlight head and flow points that are relevant for the testing criteria in Section 5.2.2.**

The third major trend is an increase in environmental performance standards. Regulators, resource agencies, local stakeholders, and environmental advocates require projects to not significantly impact a variety of ecosystem functions, which can include fish passage, sediment passage, habitat, endangered species, water quality, hydrologic variability, and more. This requirement is often expressed in the development process through environmental mitigation measures such as fish passageways, fish screens, sediment management and bypass options, and run-of-river operation (Levine et al. 2021). These mitigation measures can have significant costs, especially for smaller projects that are more cost-sensitive (Oladosu et al. 2021). Innovative environmental technologies are needed to reduce costs and improve performance to aid the value proposition of new developments, particularly within the context of climate

change, which is expected to alter water availability and variability. However, a key concern is the need for standardized efficacy assessment across technologies. Testing standards enable comparability across technologies and provide assurance to stakeholders that performance metrics are reliable. Environmental performance can often be difficult to quantify and compare between environmental conditions, so new testing capabilities and methods are needed to facilitate the development of hydropower technologies.

The last trend is grid modernization and the movements toward high market penetrations of variable renewables and distributed energy systems. Research efforts such as the HydroWIRES<sup>1</sup> initiative and the Energy Storage Grand Challenge (US Department of Energy 2020b) are investigating how hydropower can provide storage and flexibility to better enable energy systems with variable renewables, support distributed energy systems and microgrids, and provide ancillary and other grid services. Along with improvements to grid monitoring and digitization, innovations in hydropower infrastructure can support more efficient electricity systems. These technologies will require transient, dynamic, and extended duration testing and measurement techniques to ensure safe operation with increasingly complex grid conditions. In addition, emerging integrated technologies will require risk reduction with advanced next-generation governor controls, storage, grid integration, and a platform for interoperability testing, cyber-secure communication, and operational technology. This would likely require at-scale testing and prototyping of controls with nonlinear scalability of hydropower representation across sizes, designs, and configurations for hybridization with clean energy and storage technologies.

Constant production of new data for research and analysis is another major motivation to support innovative and more structured testing activities. Data produced by physical measurements are constantly sought as validation for numerical simulation and analytical modeling, which are both used for R&D, long-term monitoring strategies, and forecasts. In particular, numerical simulations have recently become a powerful tool in engineering for initial design approach, design optimization, and predictions. Improved prudent data collection allows for advanced machine learning for cyber-physical designs, prototyping, interoperability testing, cyber-secure communication, and operational technology for hydropower.

### **1.3.2 R&D Agendas Prompting Hydropower Testing**

Hydropower testing needs evolve as industry and technology change. One goal of this report is to identify current and future hydropower testing needs. Research agendas that are published and funded demonstrate the need for long-term testing capabilities. This section highlights the research priorities for several institutions that invest in hydropower R&D. These institutions include WPTO, the US Bureau of Reclamation (USBR), the US Army Corps of Engineers (USACE), hydropower industry consortia, and original equipment manufacturers (OEMs). Project catalogues, research mission statement documents, and websites were used to gather data for each institution. These priorities highlight a high-level path for future investment in hydropower testing.

#### **1.3.2.1 WPTO**

WPTO supports the research, development, and testing of new technologies for hydropower, pumped storage, and marine energy applications. WPTO's Hydropower Program works with national laboratories, industry, small businesses, universities, and other governmental organizations through a host of funding opportunities. The Hydropower Program's five core research and activity areas are outlined as follows:

1. Innovations for low-impact hydropower growth
2. Grid reliability, resilience, and integration (HydroWIRES)
3. Fleet modernization, maintenance, and cybersecurity

---

<sup>1</sup> <https://www.energy.gov/eere/water/hydrowires-initiative>

4. Environmental and hydrologic systems science
5. Data access and analytics

WPTO invests in hydropower R&D through peer-reviewed projects. These projects are reviewed biannually by a committee of reviewers, and the results are published in the respective biannual reports. Reports for 2019, 2017, 2014, 2011, 2010, and 2009 are available from WPTO.<sup>2</sup> The project descriptions were used to classify the projects according to the testing framework described in Section 1.4. The total investment and project count was fairly even among projects involving physical infrastructure and nonphysical projects such as studies, data analysis, and administrative tasks. Of the physical projects that could explicitly use testing capabilities, the largest category was powertrain technologies. Powertrain projects involved low-head turbines, modular powertrain technologies, fish protection, advanced materials, and hybrid systems. Additionally, a subset of research activities included pilot projects aimed at demonstrating the performance of powertrain technologies at scale. NPD retrofits, canal/conduit projects, and hybrid systems are technology applications of particular interest. Several core research areas address the modernization and digitalization of hydropower technologies through technologies such as embedded sensors, digital twins, and intelligent control systems. Environmental technologies, such as fish tracking and passage systems, are also important to the research missions and require testing and validation. Overall, the WPTO mission is heavily involved in the testing of new hydropower technologies and focuses on the performance of technologies across environmental and economic domains.

### 1.3.2.2 USBR

USBR is a governmental agency that manages, develops, and protects water and related resources. USBR is the second largest hydropower producer in the United States; it has constructed more than 600 dams and reservoirs<sup>3</sup> and supports research into hydropower related projects through the Research and Development Office’s Science and Technology Program.<sup>4</sup> USBR’s 2018–2022 Science Strategy documents five primary research areas and their subcategories, as listed in Table 1 (US Bureau of Reclamation 2017).

**Table 1. USBR’s 2018–2022 Science and Technology Program research priorities.** Boldface, italicized text indicates research categories that are applicable to the hydropower testing needs described in this report. Adapted from the US Bureau of Reclamation (2017)

Research area	Research category
Water infrastructure	<ul style="list-style-type: none"> <li>• <b><i>Dams</i></b></li> <li>• <b><i>Canals</i></b></li> <li>• <b><i>Pipelines</i></b></li> <li>• <b><i>Miscellaneous water infrastructure</i></b></li> </ul>
Power and energy	<ul style="list-style-type: none"> <li>• <b><i>Hydropower plants</i></b></li> <li>• <b><i>Energy efficiency</i></b></li> <li>• <b><i>Pumping plants</i></b></li> <li>• Non-hydropower renewables</li> </ul>
Environmental issues for water delivery and management	<ul style="list-style-type: none"> <li>• <b><i>Water delivery reliability</i></b></li> <li>• <b><i>Invasive species</i></b></li> <li>• <b><i>Water quality</i></b></li> <li>• <b><i>Sediment management</i></b></li> <li>• River habitat restoration</li> </ul>

<sup>2</sup> <https://www.energy.gov/eere/water/water-power-program-peer-reviews>

<sup>3</sup> <https://www.usbr.gov/main/about/mission.html>

<sup>4</sup> <https://www.usbr.gov/research/st/index.html>

Research area	Research category
Water operations and planning	<ul style="list-style-type: none"> <li>• Water supply and streamflow forecasting</li> <li>• Water operations models and decision support systems</li> <li>• Open data</li> <li>• Climate change and variability</li> </ul>
Developing water supplies	<ul style="list-style-type: none"> <li>• Advanced water treatment</li> <li>• Groundwater supplies</li> <li>• Agricultural and municipal water supplies</li> <li>• System water losses</li> </ul>

The Science and Technology Program implements its science strategy through R&D projects, prize competitions, technology transfer, and dissemination of research results (US Bureau of Reclamation 2017; 2021b). Projects range in topic and scope (a full list is available on USBR’s website<sup>5</sup>). An analysis of 360 projects within the power and energy research category and the latest Research Updates report (US Bureau of Reclamation 2021a) found that approximately half of the projects involve physical infrastructure or technology that could directly involve testing, as opposed to nonphysical administrative or modeling projects. Common project categories among the 360 projects include monitoring equipment, maintenance practices, coatings, conveyance and structural materials, and geotechnical sensing. Numerous projects, such as underwater remotely operated vehicles and robotics for pipe realignment, focus on the safety of performing maintenance. Other projects, such as algae-resistant linings and cavitation detection techniques, focus on minimizing maintenance and identifying when maintenance is needed. Overall, the USBR project portfolio is largely focused on the maintenance and improvement of existing USBR infrastructure.

### 1.3.2.3 USACE

USACE is a governmental organization that provides engineering solutions for vast amount of US infrastructure, including dams and hydropower plants. Through its Hydropower Program, USACE is the largest producer of hydropower in the United States, with 356 generating units.<sup>6</sup> USACE supports hydropower R&D in several ways, including through investment into its existing fleet, through its research centers (namely the Engineering Research and Development Center, Hydropower Design Center, and Hydrologic Engineering Center), and through partnerships with other organizations. USACE’s 2020–2024 National Hydropower Program Strategic Plan outlines the following goals (US Army Corps of Engineers 2019):

- **Goal 1:** Transform operations and maintenance to ensure future reliability, flexibility, and competitiveness of our energy resources.
- **Goal 2:** Effectively apply funding to asset improvements that are driven by data, informed by external water resource and power marketing requirements, and prioritized based on maximizing return on asset investment.
- **Goal 3:** Ensure confidence in the long-term value of hydropower assets by cultivating partnerships and engaging in outreach.

Although these goals do not explicitly specify technology areas, goals 1 and 2 align with WPTO’s agenda regarding facility modernization/digitalization and maintenance of existing infrastructure. Research areas

<sup>5</sup> <https://www.usbr.gov/research/projects/index.html>

<sup>6</sup> <https://www.usace.army.mil/Missions/Civil-Works/Hydropower/>

of interest such as generator failure analysis, remote operation, equipment age monitoring, transformer insulation methods, invasive species exclusion, self-lubricated bushings, and environmentally acceptable lubricants have been highlighted in personal communications with USACE.

#### **1.3.2.4 TVA**

The Tennessee Valley Authority (TVA) is a federal hydropower operator that is pursuing R&D to address the changes within the hydropower and electric utility industries. TVA owns and operates 29 hydropower plants in the Tennessee region, including a 1.65 GW pumped storage plant on Raccoon Mountain. TVA operates as a public power company and has an innovation and research division that supports a wide variety of renewable energy, electrification, and other grid service research programs.

#### **1.3.2.5 Hydropower industry consortia**

Hydropower industry consortia bring industry stakeholders together to collaborate on policies, innovations, and technologies that affect the entire industry. Examples of industry consortia are the Center for Energy Advancement through Technological Innovation (CEATI),<sup>7</sup> the Electric Power Research Institute (EPRI),<sup>8</sup> and the National Hydropower Association (NHA).<sup>9</sup> These consortia are often funded by industry, and although participation from larger industry stakeholders is significant, they do not represent all stakeholders, especially smaller companies that may not be able to afford entry fees.

An analysis of approximately 264 CEATI publications reveals a focus on powertrains (~38% of publications) followed by focuses on structures and conveyance (27% and 21% of publications, respectively). The focuses of these projects are aligned primarily with reliability, resilience, maintainability, efficiency, and performance design objectives of installed and operating hydropower assets, consistent with the aims of the Hydraulic Plant Life, Hydropower Operations and Planning, and Dam Safety Interest Groups. Validation (testing) of innovative components and methods is undertaken by CEATI, but primarily at full scale within operating facilities of CEATI members, and generally in cases for which the technology risk and consequences of failure are minimal and outweighed by the potential for incremental benefits of deployment or wider adoption of validated best practices.

An analysis of approximately 203 EPRI publications reveals a balanced focus between powertrains and conveyance applications (41% and 40% of publications, respectively). Environmental interactions and technologies appear to be a focus of EPRI hydropower research (55% of publications), with secondary focuses on reliability, resilience, maintainability, efficiency, capacity, and flexibility. Notable examples of EPRI technology research include efforts to advance the Alden Research Laboratory/NREC fish-friendly turbine (Foust et al. 2011) to commercial deployment, laboratory testing of turbine blade leading edge shapes for fish-friendliness, and full-scale in situ and laboratory flume research of environmental interactions through the Eel Passage Research Center, established in 2013 by EPRI with major funding from Ontario Power Generation, Hydro-Québec, New York Power Authority, and Duke Energy.

#### **1.3.2.6 OEMs**

OEMs have product lines established through internal proprietary technology development and design practices developed over time with multiple customers. Testing and validation of incremental improvements and site-specific customization of designs are often a part of the customer- and application-

---

<sup>7</sup> <https://www.ceati.com/>

<sup>8</sup> <https://www.epri.com/>

<sup>9</sup> <https://www.hydro.org/>

specific development and delivery of products to customers (for example, the model and full-scale turbine performance testing described in Section 2.1).

### 1.3.3 Sources of Testing Specifications

The advancement of a hydropower technology from concept to commercialization and widespread use requires science, engineering, environmental assessment, regulatory oversight, construction, and best practices for operations and maintenance. Testing plays a role throughout most of this advancement, such that a collection of testing activities, capabilities, and facilities must draw upon multiple domains and stakeholder sectors to be comprehensive. Whereas the previous section addresses research agendas that establish the long-term motivations and value for testing, this section addresses the sources of specifications and methods for how such testing should be done. Information is drawn from testing activities as described in publications from five major source areas:

1. Peer-reviewed science and technical publications—scholarly publications (journals) addressing domains of mechanics, hydraulics, electricity, energy, structures, ecology, and biology, among others
2. Research and technical publications from industry forums and consortia—technical conference and symposium proceedings, CEATI publications, and EPRI publications
3. Regulatory and resource agency guidance and regulations—from the Federal Energy Regulatory Commission, the US Fish and Wildlife Service, National Oceanic and Atmospheric Administration Fisheries, the US Environmental Protection Agency, USACE, and OSHA (Occupational Safety and Health Administration)
4. International and national standards publications—including ASME,<sup>10</sup> ASTM International,<sup>11</sup> IEC,<sup>12</sup> ANSI,<sup>13</sup> ISO,<sup>14</sup> IEEE,<sup>15</sup> and NERC<sup>16</sup> standards, and ASCE Manuals of Practice<sup>17</sup>
5. Research agendas, research reports, and technical guidance from agencies with hydropower-relevant research missions and facilities—including DOE, USBR, USACE, the US Geological Survey, the US Environmental Protection Agency, the California Energy Commission, and the New York State Energy Research and Development Authority

## 1.4 STRUCTURING AN ASSESSMENT OF HYDROPOWER TESTING NEEDS

A hydropower facility is a complex integration of systems and subsystems, requiring an interdisciplinary and hierarchical treatment to understand how its constituents function in part and as a whole, and how they may be tested. Thus, hydropower testing needs are complex and varied, with multiple factors to determine the facilities, equipment, resources, and methods required to yield useful results for evaluation of hydropower technology efficacy. A discussion of testing naturally leads to a discussion of success (i.e., efficacy) and failure (i.e., inefficacy) in relation to a set of design objectives. Failure in this testing context includes inadequate performance, unmitigated hazards to health and safety, inadequate reliability,

---

<sup>10</sup> <https://www.asme.org/>

<sup>11</sup> <https://www.astm.org/>

<sup>12</sup> <https://www.iec.ch/homepage>

<sup>13</sup> <https://www.ansi.org/>

<sup>14</sup> <https://www.iso.org/home.html>

<sup>15</sup> <https://standards.ieee.org/>

<sup>16</sup> <https://www.nerc.com/Pages/default.aspx>

<sup>17</sup> <https://ascelibrary.org/doi/full/10.1061/9780784478998.ch05?src=recsys>

and unacceptable interactions with the environment. Thus, the first two factors to consider, which are intrinsic to hydropower technology and describe the hydropower technology landscape, are as follows:

- A. **The physical design hierarchy** is divided into five major categories—powertrains, conveyances, structures, electrical interconnections, and instrumentation and controls (I&C). A technology that requires testing is categorized according to its position within an equipment hierarchy specification for a hydropower facility. Each of these major hydropower systems may be disaggregated into components according to one of several published hydropower equipment hierarchies.
- B. **Design objectives** represent the multiple scopes for which a specific technology is designed, but they also determine, in part, the type of test facility, sensor types, and monitoring regimes that are required to produce outputs necessary to validate efficacy and determine ways to mitigate failure. In more specific terms, the four categories of design objectives are as follows:
  - a. *Health and safety* (H&S) address hazards to operators, workers, public, and property. Safety design (and by extension, safety testing) addresses the inherent systems and measures within technology to mitigate hazards, ensuring that failure is not initiated or, when failure is initiated, the realized consequences are minimal (Verma, Ajit, and Karanki 2016).
  - b. *Reliability, resilience, and maintainability* (RRM) address the capability to operate as intended (without failure or with an acceptably minimized frequency of failure) with predictability and longevity, and to withstand rated and extreme conditions without significant damage or extended loss of service. Testing and designing for resilience includes resolving and mitigating potentially harmful interactions among systems by establishing design bases for related systems and components (for example, designing pressurized conveyances to withstand pressure pulsations and transient pressure extremes resulting from turbine instability or emergency shutdown).
  - c. *Efficiency, capacity, and flexibility* (ECF) of energy conversion or water throughput are selectable design objectives that often create trade-offs for designers. Flexibility connotes value propositions of (1) functioning effectively over a range of operating conditions and (2) modulating or ramping output frequently or quickly to maintain stability of related systems. The clearest examples of technological components with these design objectives are generators and hydraulic turbines. Spillways, sluices, trash racks, screens, fishways, pumps, and other flow-through components also have these design objectives and require testing.
  - d. *Environmental interactions* (EI) convey a host of design objectives that address fish passage, recreational use of water, water quality alteration, streambank and streambed erosion, sediment deposition, and other environmental concerns or enhancements that may result from installation and operation of a technology. Testing related to EI typically includes measurement and monitoring of biological (physiological or behavioral), chemical, or fluvial interactions with the technology in addition to the hydraulic testing required for other design objective categories.

These factors also affect the design of facilities to test the technology, as well as the computational simulation and validation for testing. An additional consideration involves various factors that are intrinsic to the testing of hydropower technology (and important in the specifications and design of a testing facility) rather than the technology itself. Five primary **test factors** are as follows:

- 1. **Scale** may be *partial scale* or *full scale*. Traditional hydropower designs and determinations made from interpretation of testing outcomes rely on assumptions of dimensional similitude and scaled components as homologs to full-scale, field-installed (in situ) components. Greater scales of testing require facilities with larger geometries and equipment to handle test articles, and they require



facilities to provide greater flow rates of water, greater pressures, and greater forces or torque to be applied to test articles.

2. **Water condition** may be *dry*, *immersed*, or *flow-through*. Some technologies may be tested adequately without being in contact with water, such as gearboxes (notwithstanding the need for lubrication using oil or water) and generator components. Other components may need to be immersed in quiescent (non-flowing) water to test them under hydrostatic pressure conditions. Still other components, such as gates, valves, and turbines, need to be tested under flowing water conditions to assess their performance with realistic hydrodynamic loads, stresses, and relative motions imposed.
3. **Completeness level** indicates whether the innovation is tested as the *full system* or as a *component* (e.g., a coupon, a unit or multi-unit, or a combination of different components). System completeness relates to physical design hierarchy in that it describes how much of the hierarchy is included in the testing scope. The selection of one of the levels of completeness is made to either (a) isolate the testing conditions, outcomes, and causes of outcomes to the test article, or (b) ensure that the interface of the test article with its planned environment or encompassing system is assessed. The hydroelectric machine is the most obvious example of the single (unit) and arrayed (multi-unit) levels of system completeness, and other cases of single and arrayed units include spillway bays, sluices, intake and draft tube gates, oxygen diffusers, and fishways, in which the interactions between units may be important to test.
4. **Time variance of ambient conditions** may be *steady-state* or *transient*. Test articles may be designed for steady-state conditions (even multiple steady-state conditions) of load, flow, pressure, temperature, water quality, or other environmental parameters, and may not require a test facility to modulate environmental/ambient conditions. However, components may be designed to survive, mitigate, or respond in desirable ways to rapidly varying loads, flows, pressures, or environmental conditions, which would require a facility with the capability to impose such time-varying conditions on a test article.
5. **Response characterization** may be *static*, *dynamic*, or *monitored/trended*. Even in steady-state ambient conditions, some test articles may exhibit fluctuating/periodic (dynamic) or evolving (trending) responses that must be resolved through high-frequency data acquisition, extended monitoring durations, or both. The types of sensors, data acquisition, and data storage necessary to provide static vs. dynamic response characterization vary. Extended duration monitoring and trending of test article response introduces additional requirements for test facility scheduling, monitoring, and data acquisition and storage systems.

The costs a technology are crucial to design (including material, deployment, and operation costs), but the scope of testing described by these dimensions focuses on the function of the technology. The methodology presented throughout this report is arranged primarily according to the described intrinsic dimensions of the technology (i.e., physical design hierarchy and design objective).



## 2. OVERVIEW OF CURRENT AND EMERGING HYDROPOWER TECHNOLOGIES

This section introduces the physical design categories and the potential testing needs relevant to emerging hydropower technologies. The section is subdivided into the five main categories of the physical design hierarchy introduced in Section 1.4: powertrain, conveyances, structure, electrical interconnections, and I&C. For each category, a high-level overview of the technology and examples of typical principal components are provided. Then, emerging hydropower innovations and technologies that will soon approach the market or that could spark new research avenues in response to hydropower upcoming trends are highlighted. For each physical design category, some of these emerging technologies may benefit from existing testing procedures and capabilities, whereas others may require new testing techniques, instrumentation, and/or facilities. These discussions will ultimately inform current testing challenges discussed in Section 3 and the evaluation of new testing requirements in Section 5. An overview of conventional testing performed during design and/or development phase is provided in Appendix A, focusing on traditional procedures and instrumentations.

The validation of models, algorithms, and related data tools is inherent in the testing of hydropower technologies. These data solutions are part of the prototyping processes as they predict and assess the performance of technologies during operation. This report focuses on physical testing capabilities toward the goal of identifying unmet testing that can be met with new testing infrastructure. Although not explicitly addressed in all the following sections, data and modeling efforts are a key testing practice and should be considered as part of any proposed initiatives (Section 5).

### 2.1 POWERTRAIN

Powertrain technology is the system of mechanical and electrical machines that convert hydraulic potential energy into electricity. Baseline hydroelectric powertrain technology includes the following configurations:

- A vertical, slant, or horizontal shaft hydraulic turbine
- A three-phase salient pole synchronous generator
- An excitation system, shaft mounted or static, that supplies and regulates the amount of direct current (DC) supplied to the generator
- A main shaft coupling the generator to the turbine, stabilized by one or more guide bearings
- A thrust bearing to resist axial forces, such as hydraulic forces and the weight of vertical-axis powertrains
- Wicket gates, which are a circumferential array of actuating gates controlling flow through the turbine runner
- A governor control system actuating the wicket gates, thereby matching instantaneous load (resisting torque) to maintain a constant (synchronous) rotational speed (discussed in Section 2.5)

Hydraulic turbines convert the potential energy created by the elevation difference between water bodies (i.e., reservoirs or rivers' natural geography) into rotational mechanical energy. The two main types of turbines in conventional hydropower are reaction and impulse. The distinction is based on the physical mechanism that causes the rotation of the runner, which is defined as the whole system of hub, blades (or

buckets), and cone. Reaction turbines are fully submerged, and torque is developed by the water pressure against the blades. Conventional subtypes include Francis, integrated pump-turbine (used mostly for pumped storage hydropower), Kaplan, and propeller designs. Impulse turbines operate in air (i.e., at near-atmospheric pressure), and torque is generated by water jets impinging onto the runner buckets (converting the water pressure into kinetic energy). Pelton, Turgo, and Banki (or crossflow) are classic subtypes of impulse turbines. In reaction and impulse turbines, the flow actuating the turbine is regulated depending on the operating conditions. For reaction turbines, flow is adjusted through the wicket gates surrounding the runner, which are adjusted by the governor to control the rotational speed or power output. For impulse turbines, the jet's flow rate is controlled by needle valves actuating inside the jet and precisely changing the opening area.

The turbine runner is connected to a generator through a shaft, ultimately converting the rotational mechanical energy of the turbine into electricity. Conventional hydropower plants typically adopt three-phase salient pole synchronous generators. Pumped storage facilities can deploy synchronous motor-generators, sometimes with a frequency convertor, or asynchronous motor-generators in connection to pump-turbines to act as a generator whenever water is discharged downstream through the runner acting as turbine, or as a motor when the water is pumped back up in the reservoir.

With regard to the testing hydropower technology landscape, powertrain technologies accommodate the design objectives in the following ways:

- *H&S*—the risk to humans related to mechanical or electrical malfunction during abnormal working conditions or maintenance operations
- *RRM*—the ability of the technology to achieve its desired function over the life of the project, withstand variable operations and transient conditions for long durations, and allow maintainability in a cost-effective manner
- *ECF*—the ability of mechanical and electrical machines to convert energy in the most efficient way (hydraulic potential to mechanical, mechanical to electrical) possible, and to endure variable operating conditions
- *EI*—fish survivability through hydraulic turbines, the effects on water quality (e.g., dissolved oxygen, lubricant leakage), and other relevant environmental conditions

Appendix A.1 provides an overview of conventional powertrain testing.

### **2.1.1 Emerging Powertrain Technologies and Testing Needs**

Relative to the baseline powertrain technology, emerging technology may exhibit multiple types of innovations that require testing for validation. The advent of new intermittent renewable energy sources such as wind and solar will require increasingly more flexible powertrain technologies for new and existing hydropower plants. This change will evidently require reimagining certain designs and potentially new types of generators. Variable renewable generation also will pose a strain on conventional materials and turbine configurations. Furthermore, increasing renewable energy production will require additional storage capacity and power conditioning, which is already resulting in more pumped storage facilities and other grid resources being developed. Innovation in pump-turbines and new material for reservoirs will be crucial. Finally, environmental compatibility has become a major constraint for both existing and new hydropower developments. Although this design objective cuts across all five physical design categories, it could have particularly significant implications for new turbine designs. Powertrain testing needs are captured in the following subsections.

### 2.1.1.1 Turbine design innovations

Hydraulic turbines have reached a significant level of maturity and efficiency. Therefore, innovations will focus on new fabrication methods and advanced materials for turbines and generators, aiming at reducing construction costs and time, and improving installation, maintainability, and replacement. Standardization and scalability of turbine designs for small hydropower facilities could also help reach those goals. ORNL introduced the concept of standard modular hydropower, providing a series of specifications for the modular design rather than proposing instructions for an ideal specific technology (Witt et al. 2017). This design could include turbine-generator packages preassembled in the factory and already mounted onto preconstructed foundations, thus requiring minimal on-site installation work. Packages could also include preinstalled electrical and control systems and, if needed, environmental enhancement technologies (e.g., aeration). Modularity could be pursued for subcomponents of the units, reducing outage time caused by component replacement. Examples of this type of generation packages have been introduced as a compact, fully submersible turbine-generator assembly, such as the Amjet turbine<sup>18</sup> that uses variable speed technology and a permanent magnet generator to eliminate the need for mechanical controls, and Voith StreamDiver<sup>19</sup> and the ANDRITZ HydroMatrix,<sup>20</sup> which are bulb-type turbines that incorporate the generator into a hub on the upstream nose of the unit.

Recently, DOE funded other hydropower turbine innovative technologies, as well, including the following:

- The Eaton Corporation turbine<sup>21</sup> is a Roots-based turbine design inspired by the Eaton’s technology Roots-based compressors and expanders, to be integrated with small modular units and used at NPDs.
- Natel Energy,<sup>22</sup> as mentioned in Appendix A1.1, is proposing the Restoration Hydro Turbine<sup>23</sup>—a new unit designed to be compact (water-to-wire unit), cost-saving (no fish exclusion and minimal civil works), fish-friendly (>99% fish passage survival), and efficient (90% demonstrated efficiency).
- The Pennsylvania State University turbine<sup>24</sup> is a rapidly deployable hydropower turbine prototype designed and developed for low-head, variable flow applications. The turbine is modular, multi-bladed, and hub-less (ecological friendly, self-cleaning, low maintenance), and it is connected to a direct-rim-drive, variable speed generator. A 0.2 m prototype was tested at Applied Research Laboratory’s 0.305 m diameter water tunnel facility under variable flow conditions.
- The Percheron Power turbine<sup>25</sup> is an optimized Archimedes hydrodynamic screw turbine made of composite materials using advanced manufacturing techniques. The unit is developed and shipped fully assembled from the factory. The unit is designed to reduce equipment and installation costs. A full-scale prototype was tested at Utah Water Research Laboratory of the Utah State University with flows from 0 to 50 cfs (0 to 1.4 m<sup>3</sup>/s) and turbine speeds from 10 to 40 rpm (more than 70 test runs).

All these projects were peer-reviewed, and results are available in the 2019 Project Peer Review report published by WPTO (US Department of Energy 2020a). The shared commonality of all these recent projects was the pursuit of a compact, standard, modular design for low-head applications. Because of

---

<sup>18</sup> <http://amjethydro.com/>

<sup>19</sup> <https://voith.com/corp-en/hydropower-components/streamdiver.html>

<sup>20</sup> <https://www.andritz.com/products-en/hydro/products/hydromatrix>

<sup>21</sup> <https://www.energy.gov/sites/prod/files/2017/04/f34/cost-optimization-modular-helical-rotor.pdf>

<sup>22</sup> <https://www.natelenergy.com/turbines/>

<sup>23</sup> <https://www.natelenergy.com/turbines/>

<sup>24</sup> [https://www.energy.gov/sites/prod/files/2019/12/f69/06\\_EE0006928\\_PSU\\_Fontaine\\_FINAL.pdf](https://www.energy.gov/sites/prod/files/2019/12/f69/06_EE0006928_PSU_Fontaine_FINAL.pdf)

<sup>25</sup> [https://www.energy.gov/sites/prod/files/2019/12/f69/07\\_EE0007247\\_Percheron\\_Straalsun\\_FINAL.pdf](https://www.energy.gov/sites/prod/files/2019/12/f69/07_EE0007247_Percheron_Straalsun_FINAL.pdf)

their relatively small size at full scale (with respect to large turbines for large head and/or large flow projects), these prototypes could be tested at full scale.

### **2.1.1.2 Generator innovations and flexibility**

The increased use of wind and solar power in the electric grid has introduced some challenges. One of these challenges relates to the strong intermittency of energy delivery of these resources, which leads to an increase in residual load (i.e., the difference between electricity consumption from the grid and non-adjustable generation). Pumped storage hydropower is currently one of the most attractive and efficient solution to store this excess production of energy. However, wind and solar generation is not only intermittent, but also highly variable, resulting in rapid changes of this residual load. This quality requires fast responses and flexible adjustments in pumped storage capacity, which cannot be accomplished by standard fixed speed pumped hydropower solutions because they can only operate at rated power, with time and energy consuming start-up and synchronization phases. To address this issue, variable speed, ternary, and quaternary pumped hydropower solutions are becoming increasingly popular. Variable speed solutions are based on two emerging generator types that use power electronic converters: converter-fed synchronous machines and doubly fed induction machines (Steimer et al. 2014; Kougias et al. 2019).

Ultimately, these generator configurations offer better active and reactive power control in pump mode, larger spinning reserve capacity, and faster start-up and change in operating mode compared with conventional pumped storage units. The standard testing of these emerging hydropower generator types should follow IEEE 1547 since inverters are either used or conceptually similar in regard to the electrical interconnection. New hydropower test facilities will need to be able to test these power electronic converter interfaces for H&S, quality, performance, RRM, and EI. Additionally, the variable speed solutions offer increased flexibility (−20% to +10% of rated power) on the pumped cycle for capturing residual load and can make ride-through faults easier. Ternary and quaternary technologies are also being investigated and proposed for flexible pumped storage hydropower. Both concepts can pump and generate simultaneously through short circuiting of the water. For ternary systems, the pump and turbine are connected to the same shaft; for quaternary systems, they may be separate machines but use similar logic. These concepts use the flexibility of the turbine-generator to accommodate the varying residual loads. Pumped water is short-circuited through the turbine to generate the difference between the varying residual load and the pump rating. For reactive power control specifically, existing plants are also exploring increased condensing capabilities through specialized operating modes and technologies such as synchronous condensers to enable fault ride-through. Minimizing the needed for synchronous condensing or the related maintenance costs through innovative designs or technologies would also be beneficial for non-PSH projects.

With variable water resources, the power output must be effectively controlled, which can be achieved using electrical machines combined with the correct controls and power conversion interface equipment. These conversion interfaces can be successfully implemented using five basic types of modern power electronics or torque converter technology, which provide higher yield of efficiency, provide reduced cost and footprint, and address the high variability of some water resources through specialized controls. Most of these alternative power conversion devices typically have a significantly reduced short circuit output and transient response owing to the smaller ratings and limitations of the equipment and machines compared with synchronous generators. The water resources that can be intermittent and rapidly fluctuate greatly benefit from these new technologies for electric power production. The five basic technology types are designed to adapt to these fluctuations in the hydropower water resources and can deliver stable electrical power generation to meet the requirements of modern and future transmission and distribution system. These five types are generally described as follows:

- Type I: squirrel cage induction generator

- Type II: wound rotor induction generator with a variable external rotor resistance
- Type III: doubly fed asynchronous wound rotor induction generator with one-third power converter connected from rotor to stator
- Type IV: full electronic back-to-back power electronic converter generator
- Type V: synchronous generator mechanically connected through a torque converter

These five basic rotating electric generator conversion methods are deployed in several industrial applications, such as in factories and for renewable energy generation, such as wind power turbine generators and geothermal electric generation systems. Each generator method is outlined in an IEEE Power System Relay Committee joint report<sup>26</sup> with the IEEE T&D PES and Electrical Machinery Groups of IEEE. This reference document adequately describes many of the details associated with integrating these generator technologies into the power grid and should provide input for facility testing of emerging hydropower generators.

A valid alternative for low-head small hydropower are variable speed permanent magnet generators, such as those recently funded by DOE (Kinloch 2015). This technology uses one power converter box to adjust the output voltage and frequency of the generator, allowing the turbine to spin following the peak efficiency of the available head. Permanent magnet generators eliminate the need for a contactor, exciter, voltage regulator, auto-synchronizer, speed increaser, and speed-matching controls. These systems can easily replace induction generators that are typically used for small low-head hydropower developments. Permanent magnet generators are already commonly used for wind turbines. Similarly, superconducting generators are also being proposed for wind energy applications. Superconducting machines can provide high torque and efficiency because of the reachable high magnetic loading and/or electric loading, resulting in light and compact electric machines (Wang et al. 2016). Superconducting materials lead to high efficiency because they display no resistance to the flow of electricity under certain low-temperature conditions. New materials are exhibiting superconducting properties at temperatures that can be reached using commercially available cooling systems. Therefore, the use of superconducting generators could be extended to hydropower applications very soon. For instance, E.ON Wasserkraft GmbH recently successfully replaced one of the three 1.25 MW twin Francis turbine-generators with a 1.7 MW machine using high-temperature superconductors.<sup>27</sup>

Magnetic gears are another emerging technology currently receiving significant attention and funding, mostly from the wind energy sector, which heavily relies on transmission gears. Magnetic gears execute the same function of mechanical gears (i.e., transferring power between high-torque, low-speed rotation and low-torque, high-speed rotation) using the modulated interaction of magnetic fields instead of the physical contact of interlocking teeth (Bird and Williams 2018; Praslicka et al. 2021). The absence of physical contact reduces (or even eliminates) the wear of the material and mechanical damages caused by overloads, thus improving the reliability and durability and reducing expensive maintenance. Therefore, magnetic gears could be extended to hydropower, as well, considering that small hydropower applications often use a speed increaser or gearbox to drive the generator at a faster speed than that of the runner. DOE recently provided federal funding to Emrgy to develop and test new magnetic gears for hydropower drivetrain.<sup>28</sup>

---

<sup>26</sup> <https://www.pes-psrc.org/kb/published/reports/Fault%20Current%20Contributions%20from%20Wind%20Plants.pdf>

<sup>27</sup> <https://www.hydroreview.com/world-regions/superconductor-technology/#gref>

<sup>28</sup> <https://www.energy.gov/sites/prod/files/2017/04/f34/magnetic-gears-hydropower-drivetrains.pdf>

### 2.1.1.3 Environmental testing

Hydropower turbines play an important role in the environmental performance of hydropower plants and have been a focal point for research and innovation. Unlike conventional turbine or generator testing, environmental testing of turbines is not standardized across the industry. Instead, environmental testing practices stem from the studies required by regulators during the licensing process. The ORNL Hydropower Mitigation Database<sup>29</sup> documents thousands of these mitigation measures and studies from hydropower license documents submitted between 1998 and 2013. The two areas of particular importance to powertrain technologies are turbine entrainment or mortality studies and powerhouse aeration studies. These areas have been studied in the past, and innovative testing methods and technologies could reduce the costs of these studies and the risks to biota.

Turbine entrainment studies aim to understand the effect of hydropower powerhouses on local and migratory species. At full scale, traditional techniques include collecting and tagging fish, sending the fish through the turbine unit, recollecting and holding the fish for one or more days, and physically assessing the potential blade impacts. The monitoring and tagging technologies needed for these studies are discussed in Section 2.5. High-speed cameras and fish autopsies can help provide an understanding of the modalities of fish impairment (i.e., blade strike, pressure, cavitation, and shear/turbulence) (Pracheil et al. 2016). Fish-safe turbines are an emerging technology that leverage this information to design blades and hydraulic regimes that minimize this risk of injury. Studies must also examine the performance of fish screens and other exclusion devices that guide fish away from the powerhouse. Exclusion devices may not work for all species and may impinge fish if velocities are too high for the target species' swimming capabilities. Turbine mortality testing has been done at partial scale, using beads or model fish to represent the movement of fish through scale turbines. Technologies such as the Sensor Fish and Gelfish allow scientists to gather data about the fish's experience without capturing and injuring live fish (Deng et al. 2014; Saylor 2021; Saylor et al. 2021). In particular, Sensor Fish, developed by Pacific Northwest National Laboratory (PNNL), is a proven tool for turbines characterization that has been validated in lab and field environments and used for various molding materials and sensors at considerably high TRLs (Martinez et al. 2019; 2020). The main challenge for turbine mortality testing is that mortality can depend on the species, life stage, turbine shape, flow conditions, environmental conditions, and testing methods, so it often must be done as part of the licensing process. New testing capabilities must consider the ability to house and study a variety of species in closed-loop or isolated system to prevent the introduction of invasive species or diseases.

Turbine aeration and water quality are other important areas of powertrain testing. Turbines often draw water from low levels in the reservoir that are colder and have lower dissolved oxygen concentrations than the upper layers. Aerating turbines mix air into the water that spins the turbines to improve the water quality downstream. Aeration studies test the effectiveness of the aeration across the turbine and can examine the impacts on turbine efficiency. As discussed in Section 2.5, water quality monitoring technologies, such as dissolved oxygen sensors, are important for tracking water quality along the powertrain (Salalila et al. 2020). An emerging area of related study is the impact of greenhouse gas emissions from turbines. Anoxic environments in the bed of the reservoir can produce methane and other greenhouse gases that are emitted when water is withdrawn from low levels. Testing and studies are needed to understand and mitigate the resulting emissions from the powertrain.

### 2.1.1.4 Advanced materials and manufacturing innovations

Advanced manufacturing techniques could have tremendous impacts on powertrain innovations, especially for small hydropower turbines. Additive and advanced manufacturing could improve turbine

---

<sup>29</sup> <https://hydrosourc.ornl.gov/dataset/us-hydropower-mitigation-database>

reliability and durability, and reduce production time and costs. Turbines will also benefit from state-of-the-art and new materials. For example, composite materials could be good candidates for hydropower runners owing to their great structural performance, reliability, and resistance to corrosion. These materials have been largely employed in the wind energy industry where turbine blades are typically made in polyester or epoxy reinforced using fiberglass, carbon, and/or Kevlar. Hydrokinetic turbines are following a similar path considering the similarity with wind turbine designs. However, water-specific tests are typically performed for hydrokinetic machines. Similarly, the use of innovative materials for hydropower runners will require specific tests to ensure that they can withstand load, tension, compression, inter-laminar shear, impact (low- and high-speed), and environmental durability. Conventional tests such as those specified by ASTM International and ISO could be applied, and other new testing specifications might need to be introduced. For instance, composite materials applied in water might require specific tests for cavitation, corrosion, and water absorption. Recently, Composite Technology Development<sup>30</sup> proposed and tested innovative new composite and replaceable blades for hydraulic turbines. Composite materials were proposed for the main structure and for coating, aiming at reducing manufacturing and operating costs while increasing energy capture. PNNL has also conducted studies using composite materials for small hydropower blades. Carbon fiber-reinforced thermoplastic blades were developed and tested in a lab-scale turbine performance test loop to compare with stainless steels blades of the same design (Li et al. 2019). Composites could also be used for other parts of the powertrain system, such as the flow-guiding vanes. For example, laboratory tests were conducted at the Pennsylvania State University Applied Research Lab on composite blades in bench tests (load and fatigue) and mounted on a scaled Voith Bulb Hydropower Turbine System and tested in a water tunnel. The same group is planning on testing a similar composite runner system at full scale in the near future.

Advanced materials and manufacturing technologies techniques play a crucial role, and will continue even more in the future, in maintenance (repair or replacement) of installed powertrain components. Examples include cold-spray repair of cavitation damage, new coating technologies, environmentally acceptable lubricants, and replacement of metal alloy components with polymer composite components.

## 2.2 CONVEYANCES

Conveyances are systems or structures that enable water to move through the hydropower facility from the upstream side (reservoir or river reach) to the downstream side (back to the main river). Although water is typically what conveyance structures are linked to, it is not the only element that can (or should) be passed through a dam. To improve the sustainability of hydropower facilities, novel designs and technologies are introduced to ensure the continuity of sediments and fish through the flowing water. Recreation structures are also designed to allow the passage of boaters. Therefore, in general, any structure that allows the transition of water and water constituents from upstream to downstream can be classified as a conveyance.

Examples of conveyance technologies include the following:

- *Head-race or power canals*: channels that direct the water from the reservoir to the generation section intake
- *Intakes*: openings that collect the water from the head-race and direct it to the generation section, transitioning from an open channel to a closed conduit condition; trash racks made of wood or metal are usually installed in front of intakes to prevent anything that can damage the turbine (e.g., logs, debris, ice) from entering the conduit

---

<sup>30</sup> [https://www.energy.gov/sites/prod/files/2019/12/f69/08\\_EE0007248\\_CTD\\_Fabian\\_CompositeHydro\\_FINAL.pdf](https://www.energy.gov/sites/prod/files/2019/12/f69/08_EE0007248_CTD_Fabian_CompositeHydro_FINAL.pdf)

- *Tunnels*: typically low-pressure systems excavated underground
- *Penstocks*: pressurized conduits, made of steel or concrete, that convey water from the intake (or tunnel) to the turbine
- *Surge tanks and pressure relief valves*: systems designed to release pressure surges caused by transient operation (e.g., load rejection and waterhammer)
- *Draft tubes*: tubes (typically divergent) that connect to the exit of the turbine to the tailrace channel (i.e., the exit of the dam)
- *Tailrace channels*: open channels or tunnels that carry the water from the powerhouse to the downstream main river system
- *Spillways*: structures located at the crest of the dam or on the side, designed to pass water flow not used for hydroelectric purposes; can be controlled or uncontrolled depending on whether gates are present
- *Gates and valves*: mechanical systems that regulate water release; usually operate at the interface of the other conveyances mentioned previously.

With regard to the testing hydropower technology landscape, conveyance technologies accommodate the design objectives in the following ways:

- *H&S*—the risk to humans and biological constituents during passage of water
- *RRM*—the ability of the conveyance technology to achieve its desired function over the life of the project
- *ECF*—the ability to efficiently convey the water constituents within the design specification, and to withstand future fluctuations
- *EI*—the effects of conveyance technologies on local species, water quantity and quality, ecosystem health, and other relevant environmental conditions

Appendix A.2 provides an overview of conventional conveyance testing.

### **2.2.1 Emerging Conveyance Technologies and Testing Needs**

Although hydropower is a well-established resource and technology, innovative solutions are constantly sought to minimize costs and improve environmental compatibility. These goals can be reached specifically through advancements in conveyance structures that allow for continuity in river functionalities (water-biota-sediments-recreation) and can improve the environmental footprint. Novel conveyance designs with complex geometries and new materials might lead to reexamining conventional testing procedures and measuring techniques. Furthermore, changes in national and international energy portfolio and/or grid innovations will likely translate into new evolving hydropower operating conditions. These changes are likely related to fast-growing expansion of more intermittent renewable energies, which could benefit from the flexibility of hydropower systems, or the increasing adoption of pumped storage hydropower solutions. As described in Section 2.1, these changes will have implications mostly on powertrain systems and therefore will affect water conveyance technologies, as well. This subsection



identifies some of the key innovations within the hydropower conveyances field and the consequent validation needed to justify commercialization to buyers and developers.

### 2.2.1.1 Water conveyances

The primary element to be passed through and over a dam is water. As mentioned in previous sections, hydraulic conveyances are one of the most studied and tested design features of a hydropower plant. However, several innovations and changes call for new designs and thus new validations.

Examples of water conveyance technologies or topics that require testing include the following:

- **Environmental mitigation:** Combination of water passage with fish passage structures may improve the environmental mitigation strategy at several new and existing hydropower plants (Section 2.2.2.2). Similarly, water quality improvements could be reached by introducing aeration in conveyances, such as in spillway crests and/or gates, or through innovative designs for stilling basins. Aerating weir designs could benefit from non-canonical shapes that can be obtained by combining advanced manufacturing techniques and new materials (also addressed hereafter). These types of technology will require a combination of hydraulic measurements (e.g., hydrodynamics, flow visualization, pressure fields) with chemical and biological tests to validate the positive ecological effects of water quality improvements. A testing facility may not have all those testing capabilities, but they will be needed to validate all the design objectives of a technology, with particular focus on EI. Given the nature of these tests and the challenge to scale some of these interactions (e.g., with fish), these requirements call for full-scale testing, environmental instrumentation innovation, and coordination among facilities with different testing capabilities.
- **Erosion control and prevention:** Erosion can be a destructive mechanism that occurs at interfaces of river beds, structures, materials, and so on, and the boundary layer of flowing water. This can occur in sediment beds as well as at the surface of coatings of materials. In river beds, higher than expected velocities may mobilize bed material, resulting in erosion and scour exceeding design criteria, which compromises the safety conditions for structures since catastrophic failure can occur and cause excessive downstream flooding. For example, researchers investigated the conditions contributing to erosive mechanisms that compromise the reliability and safety associated with cantilevered spillways (Khusankhudzaev and Jahonov 2020). Scale model studies enabled investigations of different design adjustments to minimize and prevent local erosion effects. Sediment-laden water flow can also act as an abrasive force to hydraulic structures, seals, and other components. To assess hydro-abrasive resistance for penstock coating systems, researchers develop new methodology and laboratory experimental device to subject test specimens with various coatings to wear conditions caused by erosion (Aumelas et al. 2016). Erosion control will call for innovative material, advanced manufacturing, and potentially new designs that improve the hydrodynamics of the water release.
- **Water control structures:** Novel designs and/or configurations of water control structures are being investigated to improve hydraulic performance and energy dissipation downstream of spillways. This type of enhancement is pursued to improve the overall safety and reliability of water conveyances. For example, researchers have recently used experimental models to investigate swirled flows with oppositely rotating layers in a high-head spillway structure to dissipate energy of high-velocity flows (Orekhov 2019). Newer, more efficient trash racks are being proposed and tested in laboratory flumes to improve trash removal and water passage efficiency while preventing the rack from clogging (Itsukushima et al. 2016). Laboratory investigations were recently carried out to test the hydraulic characteristics and improved outflow efficiency performance of a side weir with linearly decreasing width in the flow direction inserted in a converging channel (Maranzoni, Pilotti, and Tomirotti 2017).

- Advanced manufacturing nonconventional materials:** As introduced in Section 2.1.2.4, the advent of alternative materials and advanced manufacturing techniques will likely benefit emerging technology across all five physical design categories of the hydropower landscape. A recent cost analysis conducted by ORNL found that near-term innovations might adopt non-steel materials for water conveyance and penstocks to reduce costs and improve flexibility for maintenance and retrofits (Oladosu, George, and Wells 2021). Fiberglass-reinforced plastic, centrifugally cast fiberglass-reinforced polymer mortar (e.g., Hobas<sup>31</sup>), and high-density polyethylene (e.g., Weholite<sup>32</sup>) could be used for penstocks, draft tubes, and other pressurized conduits. Alternative materials could also be explored for other larger conveyances (e.g., spillways, fish, and boat passages), but they will likely be associated to modular designs. Examples include new technologies for inflatable rubber structures and pneumatically actuated gates, such as those offered by Obermeyer Hydro.<sup>33</sup> These modular water control structures are recently receiving increased attention from the industry for their flexibility in water-control strategies and low costs (Gebhardt 2013). This technology is completely modular, which reduces the capital investment and maintenance, and it can be used to update existing dams or develop new low-head sites. Elastic materials are also being tested for water retention and storage; for example, a polyester-based fabric with flexible PVC coating was proposed as a floating membrane reservoir system for closed-loop pumped storage hydropower (Hadjerioua et al. 2019). Properties of materials (e.g., reliability, durability) could be tested in the lab on a single coupon (Section 2.3, structural testing) but may also require updated validation processes that are not necessarily in line with conventional testing. Conversely, the performance and efficacy of the whole structure (e.g., the gate operations for Obermeyer, the storage capacity of the membrane or the resistance of polyethylene penstocks) might require a prototype model and/or full-scale study.
- Climate change:** The effects of climate change pose a serious threat to the hydraulic safety of structures, which may not be up-to-date to face changes in flood and drought frequencies and intensities. Modifications of the water release schedules to adapt to different generation operations might also reveal a need for more reliable and durable structures that will have to be validated, especially for new transient applications.

### 2.2.1.2 Fish conveyances

New innovative solutions for fish passage can introduce complex design with untested hydrodynamic performance that will require new ways of testing. In this example, the EI of the proposed technology are potentially the most important and obvious features to validate before commercialization can be justified. However, a streamlined procedure for environmental performance testing of fish passage technologies does not currently exist. Clear metrics and monitoring techniques are needed to assess passage efficacy, such as the threshold of survival and migration rate. In addition, the connection between the hydrodynamics of the passage and fish behavior could present new opportunities for research and novel designs.

Examples of fish conveyance technologies or topics requiring testing include the following:

- Fish behavior and passage engineering:** HydroPASSAGE is significantly improving the general understanding of fish migration through hydropower facilities (Pflugrath et al. 2020), and Parish et al. (2019) reported a comprehensive review of environmental metrics currently used to assess the impacts of hydropower developments. Validations of this kind require a multidisciplinary approach that combines hydraulics, biology, and physics, but existing testing activities that include all these

---

<sup>31</sup> <https://hobaspipes.com/>

<sup>32</sup> <https://www.weholite.com/>

<sup>33</sup> <http://www.obermeyerhydro.com/inflatableddams>

disciplines are likely uncommon. Although hydraulic performance is now a standard testing activity in hydropower, biological testing might still be a gap (Section 2.1.2.3). Fish behavior is an evolving science and represents one of the biggest complications for hydropower testing. Most efforts have focused on single species, typically salmonoids. However, different species respond differently to external stressors and thus might affect the testing approach or even the hydraulic measurements. Additionally, fish behavior might change between lab and in situ conditions. For example, attraction flows are significant when testing the passage efficacy. Different fish species possess different swimming speeds (burst speeds, prolonged, and sustained speeds) and respond differently to characteristics of turbulence and velocities of flow fields. Attraction flows are used to guide and encourage fish to passage entrances and, in many applications, interact with turbine flows in tailraces. Developing guidelines for hydraulic conditions that are amenable to successful fishway passage is of interest for meeting environmental and economic goals (Gisen, Weichert, and Nestler 2017). Testing and assessing the effect of in situ conditions such as turbine flow fields, extents of tailraces, and attraction flows on fish behavior is challenging since fish cannot be scaled for use in a partial-scale model. Therefore, facilities and resources are needed to accommodate full-scale experiments in which controlled conditions and provisions can be implemented for replicating realistic hydropower conveyances flows.

- **Fish passage and exclusion technologies:** Although there are currently no standardized testing activities, fish passage designs and fish behavior within water conveyances received substantial investment and research over the past few decades. Fish exclusion can be divided into three primary categories—physical or positive, behavioral, and trapping. Screening, bars, racks, and netting are used to physically prevent fish and larvae from being entrained into turbine intakes. Screen and bar spacing are designed such that flow velocities discourage impingement against screens. Technologies include flat-plate (horizontal and inclined) and cylindrical screens (require cleaning), traveling, drum, and Coanda screens (self-cleaning). Mulligan et al. (2019) showed through physical model testing how novel, less common fishways, such as overshot and reverse overshot gate, outperform the more common vertical gate fishways in fish passage performance. Mulligan et al. (2018) conducted a series of nine experiments to measure the 3D velocity field around a scale mode of new fish guiding walls, with varied hydraulic parameters and wall installations. Conversely, behavioral technologies consist of a suite of technologies that include light, sound, and bubbles used to safely persuade fish to navigate away from dangers and toward passage mechanisms. In some cases, these technologies can be used in combination with manipulating local hydraulic conditions at a site to encourage movement and direction of fish. Deleau et al. (2020a; 2020b) built an experimental channel within an outdoor recirculatory flume to test innovative acoustic speakers aimed at guiding eels toward the fish bypass to increase downstream-passing efficiency. Test facilities and scaled models have been developed to specifically study fish behavior within hydropower plant environments using randomly actuated synthetic jet arrays to study fish behavior in highly turbulent flows (Harding et al. 2019). Physical technologies are more effective and widely accepted by regulators because of their relatively higher exclusion rates compared with behavioral technologies. Another challenge is cost, which can vary widely based on the technology type, flow/sizing requirements, and material types. These measures can be prohibitively expensive for small projects.

### 2.2.1.3 Sediment conveyances

The dam and consequent reservoir impoundment block the natural transport of sediments and force it to deposit upstream of the structure, limiting the supply of sediments downstream (Schleiss et al. 2016). This factor has implications on the environmental sustainability and hydropower generation potential of a facility. Sediment starvation in the downstream reach can cause geomorphological changes in the river channel, such as incision, bank erosion, and/or armoring, whereas reservoir sedimentation reduces the

volume and head available for power production. Sediment conveyances are structures that allow for the evacuation of sediments trapped upstream of the hydropower facility.

Examples of sediment conveyance technologies or topics requiring testing include the following:

- **Conventional sediment conveyances:** Conventionally, three main types of sediment conveyance structures have been used in the past, namely bypasses, crest gates (i.e., sediments sluicing), and low-level (submerged) gates (i.e., sediments flushing). The bypass is a tunnel that conveys sediment-laden flows bypassing the dam, which prevents sediments reaching the reservoir. Sediments sluicing involves the passage of high-flow discharges, typically associated to flooding events and thus rich in sediments, over the dam crest and gates, to limit the sedimentation in the reservoir. Conversely, sediment flushing uses low-level gates and targets the evacuation of sediments already deposited near the dam. This is achieved by either emptying the whole reservoir (drawdown flushing) and trying to remove as much of the deposit as possible or using the head pressure to flush the sediments adjacent the gates (i.e., pressure flushing). A comprehensive review of conventional methods can be found from Kondolf et al. (2014).
- **Innovative sediment conveyances:** Newer sediment passage technologies will likely resemble the bypass strategy, thus aiming at improving the capture of sediments before they get to the reservoir, which decreases the sedimentation and efficacy of the passage. For example, the University of Minnesota recently proposed and was awarded a DOE funding<sup>34</sup> in 2019 to develop a “hydrosuction” approach that “uses siphon flow to continually pass sediment through the dam structure.” Sediments are transported both as bedload (i.e., moving bedforms on the bottom of the channel in a conveyor belt-like movement) and in suspension, depending on the sediment granulometry (smaller lighter sediments are easier to be suspended) and the turbulence level of the flow. Improving the performance of the sediment passage implies improving the ability to pass both the transport process and as much as the incoming granulometry as possible (i.e., not selecting only a specific range of sediment grain sizes). However, sediment passages should be designed to achieve specific environmental goals based on the morphodynamic and ecological condition of the river, but clear guidelines do not currently exist. Additionally, sediments could be redirected toward the inlet of the bypass using submerged vanes to maximize the collection. Specific examples of these guiding structures include the Iowa Vanes, which were first theorized and physically tested by the University of Iowa to control the sediments dynamic to protect riverbanks and pumping stations’ inlets (Odgaard and Kennedy 1983; Odgaard and Mosconi 1987; Odgaard and Wang 1991a; 1991b). Sediment passage techniques and related testing systems are relatively less represented in current literature, which might reflect a gap. Recently, Isaac and Eldho (2019) presented a 1:100 scale model of a Bhutanese hydroelectric project to demonstrate and study a drawdown flushing process for sediment removal. Auel (2014) conducted a large hydraulic-scale model study to investigate the operation, performance, and potential detrimental abrasion of novel sediment bypass tunnels.
- **Sediment flux measurement:** Conventional and innovative sediment conveyances require similar testing capabilities that are not common in hydropower technological validations. Other than using classical hydraulic infrastructure and measurements techniques, a testing facility should be able to reproduce and measure sediment transport processes (both bedload and suspended) and potentially ensure sediments recirculation. The transport capacity of the hydraulic facility should be able to be changed to mimic different transport stages (e.g., slowly changing bathymetry vs. flooding event), which typically requires a wide range of water discharge availability and variable channel slope, or a sediment feeder. Innovative technology could arise in the future to measure more efficiently and

---

<sup>34</sup> <https://www.energy.gov/articles/doe-announces-249-million-funding-selections-advance-hydropower-and-water-technologies>.

rapidly both sediment discharge and sediment granulometry at the laboratory scale and in situ. These important metrics are needed to validate the mechanical performance of sediment conveyances.

- **Sediment abrasion testing:** The resistance to abrasion induced by particles and cobbles is a fundamental test required for sediment passage structures. Similarly to other conveyances but in particular for sediments, the advent of innovative material and manufacturing techniques could improve the resistance to abrasion, and the viability of new nonconventional shapes (e.g., syphoning pipes or the guiding vanes) and modern validation techniques will be required.

#### 2.2.1.4 Boat conveyances/recreation

Boat conveyances, water parks, and recreational strategies are generally considered to improve economic and social impacts of the hydropower facility in new projects or as additions to plants seeking relicensing (Bonnet et al. 2015; Witt et al. 2017). The primary goals of recreational conveyance are typically to provide a safe and recreational passage for watercrafts (e.g., kayaks, canoes, paddleboards, other nonmotorized boats), improve recreational fishing opportunities, and potentially preserve (or improve in the case of impaired rivers) the overall ecological conditions of the site. Whitewater parks can have a range of sizes and functions from a small single stationary wave for local surfing to a large series of rapids that allow for whitewater activities such as rafting, canoeing, and kayaking. Alternatively, if boat passage cannot be allowed, lateral shore access (exit and entry) can be provided for portaging, thus including different kinds of ramps or launches.

Examples of boat or recreational conveyance technologies or topics requiring testing include the following:

- **Whitewater parks:** The most sophisticated whitewater parks passages may involve special hydrodynamic conditions that must be carefully designed and tested before use (Caisley and Garcia 1999; Caisley, Bombardelli, and Garcia 1999; Bombardelli et al. 2002; Colorado Water Conservation Board 2008). Recreation developments at hydropower facilities could be also combined with fish passage strategies or ecological restoration in general. For instance, Natel Energy is considering design concepts that incorporate dual fish and recreation passage as a part of an ongoing DOE-funded award.<sup>35</sup>
- **Advanced manufacturing:** Advanced manufacturing techniques could facilitate the adoption of more complicated shapes that could improve hydrodynamic performances but would be difficult to fabricate using conventional techniques. These new designs would require new nonconventional validation tests and physical modeling. However, because these types of conveyance directly involve interaction with people, H&S validation are the priority.

#### 2.2.1.5 Conventional hydropower designs and retrofit vs. new modular facilities

Most existing dams in the United States provide water control benefits such as flood control, water supply, navigation, and irrigation, but they do not currently produce electricity. These dams, also referred to as NPDs, represent an untapped opportunity to increase hydropower production nationwide (Hadjerioua, Wei, and Kao 2012; Hansen et al. 2021). The advantage of NPDs is that the main costs associated with dam and foundation design, construction, and materials have already been incurred. Novel water passages and power generation technologies could be developed and applied to existing structures with minimal civil intervention. Siphons, for example, are a cost-effective solution that move water over

---

<sup>35</sup> <https://www.energy.gov/eere/articles/funding-selections-announced-innovative-design-concepts-standard-modular-hydropower>

the dam, with generation potential, thus avoiding any major time-consuming and expensive modifications to the structure. These are attractive solutions to mitigate dam safety issues (preexisting or associated with the civil works required for the retrofit) and considering the rise of new, less expensive advanced materials and manufacturing techniques.

Modular designs could represent a potential new route to optimize the development costs while improving hydropower sustainability and environmental compatibility (Witt et al. 2017). Future dams and refurbished structures could take advantage of standardized modules that perform all the basic functionalities of a hydropower plant, namely power generation and water passage, and allow for the continuity of fluvial natural processes, such as sediment passage and fish migration, and recreational activities. All these structures will be completely new and will therefore require new and specialized testing, either at the laboratory scale or in situ full scale. Some examples of low-head turbines provided in Section 2.1.2.1 are designed serve this purpose and facilitate existing dam retrofits.

#### **2.2.1.6 Changing conditions**

Changes in baseline operations and conditions might also lead to newer designs and thus justify the need for new testing procedures and techniques, as discussed for powertrain technology in Section 2.1.2.2. For example, some Swiss studies (Adam et al. 2018; Adam, De Cesare, and Schleiss 2019) proposed the design of a throttling system to be implemented in the surge tank of a refurbished hydropower plant to handle extreme water levels that might occur as consequence of increased generation capacity. Different throttling systems were tested numerically and using scaled physical models. Hydropower units that are required to operate in condenser mode to supply reactive power experience decreased water levels below the runner by closing the guide vanes and experience air-water phenomena causing air losses such as in sloshing of the free-surface of the water below the runner in the draft tube cone of a Francis turbine. Partial-scale models are typically used to understand these phenomena (Vagnoni et al. 2018).

### **2.3 STRUCTURE AND FOUNDATIONS**

Structural and geotechnical technologies aim to reduce the risk of structural failure for the facility or facility components, thus enabling long-term operation. These technologies are purposed with establishing connections between facility components and the ground to (1) impound water while reducing or eliminating seepage, (2) maintain structural stability and support, or (3) house physical equipment, all in a cost-effective and sustainable manner.

Structural technologies include physical structures and the materials and methods used to assess and treat the subsurface. Examples of structural technologies include the following:

- *Geotechnical sensing methods and equipment* are intended to qualitatively and quantitatively assess the condition of subsurface materials used in geotechnical engineering practice.
- *Dam cores* are purposed primarily for impounding water, and the self-weight contributes to the dam's overall structural stability.
- *Dam fill* is purposed primarily for accomplishing dam impoundment. Similar to dam cores, dam fill's self-weight contributes to the dam's overall structural stability.
- *Cutoff walls* are designed to support dam and foundation seepage control.
- *Grouting* is applied to support structural adhesion and seepage control.

- *Filters* are designed to allow for seepage control while avoiding piping or other unintended material displacement.
- *Reservoir liners* are occasionally installed to prevent seepage and leakage of water outside the intended reservoir containment.
- *Rock anchors* are designed to fix a rigid structure to the streambed or bank in a rock foundation.
- *Riprap* is installed to provide for energy dissipation and erosion control in various parts of a dam design.
- *Powerhouses* are superstructures purposed for housing power generating equipment.

With regard to the testing hydropower technology landscape, structural technologies accommodate the design objectives in the following ways:

- *H&S*—the risk to humans during construction or implementation of structural technologies, as well as the risk to humans caused by potential failure of the corresponding structure
- *RRM*—the ability of the structural technology to achieve its desired function over the life of the project
- *ECF*—the ability of the structures to efficiently withstand the loads for which they were designed; *flexibility* refers to the range of subsurface and or superstructure conditions under which a given technology could be safely and cost-effectively applied.
- *EI*—the effects of structural technologies on local species, surface water, groundwater, greenhouse gas emissions, and other relevant environmental conditions

Appendix A.3 provides an overview of conventional structural and geotechnical testing.

### 2.3.1 Emerging Structural Technologies and Testing Needs

Several relatively new and emerging civil structures technologies offer opportunities in the hydropower industry. These innovative technologies require testing to validate their design and operational objectives. Some of these technologies include the following:

- **Manufactured formwork** offers potential cost and timeline savings during the construction process. Example applications include the Muskrat Falls hydroelectric project<sup>36</sup> in Canada, in which considerable formwork was used to expedite construction in a cold climate where the construction season is short.
- **Prefabricated concrete** offers potential cost and timeline savings during the construction process. Example applications include the French Dam<sup>37</sup> in which prefabricated components are assembled to construct a water-retaining structure.
- **Concrete printing** represents an emerging technology owing to advances in additive manufacturing processes becoming increasingly more affordable. Such manufacturing could offer considerable cost

<sup>36</sup> [https://www.doka.com/en/news/press/Muskrat\\_Falls2](https://www.doka.com/en/news/press/Muskrat_Falls2)

<sup>37</sup> <https://www.fdepower.com/hydropower/french-dam/>



and timeline savings, especially if such printing could be completed underwater, thereby reducing or eliminating the need for temporary dewatering and diversion during the project construction process. This concept is still in its infancy.

- **Modular superstructures** represent an innovative technology, pioneered in part by standard modular hydropower research<sup>38</sup> led by ORNL. Modular superstructures offer potential cost and timeline savings compared with conventional civil works methods. Example applications include the facility design concepts being explored by Natel Energy and Littoral Power Systems as a part of an ongoing DOE-funded award.<sup>39</sup> Given the diversity of superstructure functions (e.g., house power generating equipment, pass fish, pass sediment, pass recreational craft, pass water), a variety of validation steps may be required.
- **Modular foundations** represent an innovative concept that could offer cost and timeline reductions. This concept is addressed as a part of ORNL's standard modular hydropower research<sup>38</sup> and is addressed by DeNeale et al. (2020). Example applications include the concepts developed by GZA GeoEnvironmental and Littoral Power systems as a part of the Groundbreaking Hydro Prize.<sup>40</sup>
- **Anchoring** is a common geotechnical engineering technique to provide for structural stability but is not widely used for hydropower applications. Anchoring could be viewed as a form of modular foundation, and the GZA GeoEnvironmental concept awarded via the Groundbreaking Hydro Prize centers on anchoring technology.
- **Floating reservoirs** are novel and could offer cost, timeline, and environmental advantages over conventional approaches for reservoir construction. An example application is the membrane technology described by Hadjerioua et al. (2019).
- **Innovative pumped storage systems** have the potential to reduce construction costs and timelines. Example applications include the Obermeyer pumped storage system,<sup>41</sup> Quidnet's geomechanically pumped storage system,<sup>42</sup> and the ORNL GLIDES system.<sup>43</sup>

Testing of these emerging structural technologies may be required to validate structural reliability and performance, EI, biological H&S, and human H&S. All of these technologies are likely to require response characterization for strength and stiffness. Prefabricated concrete may require leakage testing, and concrete printing may require leachability testing. Modular superstructures may require durability, leakage, and abrasion resistance testing at partial or full scale. Modular foundations may require durability and seepage control testing. Anchoring technologies may require corrosion resistance testing. Floating reservoirs may require leakage, operability, corrosion resistance, and durability testing.

## 2.4 ELECTRICAL INTERCONNECTIONS

In this report, *electrical interconnections* refer to the equipment and process of connecting hydropower-based generation to the power grid. Testing the hydropower electrical interconnection is an important step in verifying whether a new hydropower resource will meet the requirements for safety, reliability,

---

<sup>38</sup> <https://smh.ornl.gov/>

<sup>39</sup> <https://www.energy.gov/eere/articles/funding-selections-announced-innovative-design-concepts-standard-modular-hydropower>

<sup>40</sup> <https://www.energy.gov/eere/water/articles/us-department-energy-announces-groundbreaking-hydro-prize-winners>

<sup>41</sup> <http://www.obermeyerhydro.com/pumpedstorage>

<sup>42</sup> <https://www.energy.gov/eere/water/articles/new-approach-pumped-storage-hydropower>

<sup>43</sup> <https://www.ornl.gov/news/energy-high-efficiency-storage>



performance, and environment interactions. For hydropower, the three main routes of connecting to the grid are to use power electronic converters (rectifiers, inverters, cycloconverters), directly connected induction generators, or directly connected synchronous generators.

- *Rectifier*: device that can convert alternating current (AC) power to DC power
- *Inverter*: device that can convert DC power to AC power
- *Cycloconverter*: device that can convert AC power of one frequency to AC power of another frequency
- *Induction generator*: device that produces electricity once its rotor is turning faster than its synchronous speed; operates similarly to an induction motor except that it runs at a faster speed (as opposed to a slower speed) and provides electricity instead of consuming it
- *Synchronous generator*: device that converts mechanical energy into synchronized AC energy by running a rotor at a constant speed

To further delve into the conventional and modern electrical interconnection testing, common metrics, equipment, and methods are defined as follows:

- *Active power*: real power resulting from resistive sources and loads that is correlated with frequency
- *Reactive power*: imaginary power resulting from inductive/capacitor sources and loads that is correlated with voltage
- *Power factor*: ratio of real power to apparent power (the product of the root mean square current and the root mean square voltage measured in volt-amps)
- *Frequency*: the measure of cycles per second of a sine wave
- *Distributed energy resource (DER)*: electricity producing resources that are connected on the distribution section of the grid
- *Islanded mode*: a mode that occurs when a power system is disconnected from the power grid and operating independently
- *Point of common coupling*: the location of where the hydropower resource is connected to the grid; also can be called the point of interconnection
- *Inverter-based resources*: renewable technology that uses inverters to connect to the power grid

With regard to the testing hydropower technology landscape, electrical interconnection technologies accommodate the design objectives in the following ways:

- *H&S*—the risk to humans caused by interconnections faults and other electrical malfunctions during abnormal working conditions or maintenance
- *RRM*—the ability of the technology to provide reliable interconnection among systems and to the grid over the whole life of the project, with easy access to maintainability of the components

- *ECF*—the resolution, range, and response time of the technology
- *EI*—the potential electrical interference with local ecosystems environmental conditions (water and air)

Appendix A.4 provides an overview of conventional electrical interconnection testing.

### 2.4.1 Emerging Electrical Interconnections Technology and Testing Needs

The primary emerging electrical interconnection technology for hydropower systems are power electronic converters (rectifiers, inverters, and cycloconverters), as opposed to fixed-speed induction generators. In the frequency conversion process using a rectifier and inverter, the variable AC output from the turbine rotor is rectified to DC, and then the inverter converts it to synchronized AC, which allows for better control over reactive power consumption or absorption. In the frequency conversion process using a cycloconverter, the AC output from the turbine rotor at one frequency is converted to the frequency required for the grid. This allows generators to spin at nonsynchronous speeds, which allows for increased efficiencies and minimized damage at nonoptimal operating points. This process is extremely similar to most wind power installations but with the source being generated from moving water rather than from wind propellers. Therefore, the testing for this category of hydropower systems could primarily follow the testing for power electronic converter-based generators, which are mainly provided in IEEE 1547 for distribution and radial sub-transmission systems, and IEEE P2800 for transmission and networked sub-transmission systems. IEEE P2800 is currently under development and is not publicly available yet. The testing focus for power electronic converter should be on H&S, quality, performance, RRM, and EI. Other considerations for testing hydropower emerging technology include advanced modeling and digital testing, microgrids testing for hydropower, hardware-in-the-loop methods, and underwater electrical interfaces.

#### 2.4.1.1 Testing for inverter-based hydropower electrical interconnection

IEEE 1547 specifies various parameters that must be satisfied before a DER can be connected to the electrical power system (EPS), and requirements for when DERs must be separated from the EPS during abnormal conditions. This standard is not intended to cover testing for product safety. It is more focused on the safety of the equipment under test used for an interconnection from the EPS to a DER. To determine if a DER can be safely connected to the EPS, various standardized tests and evaluation procedures involve factors such as voltage, current, frequency, and response to islanding situations that must be within the test limits.

The tests that are applicable to innovative testing of inverter-based hydropower resources include the following:

- *Cease to energize testing* verifies that the DER does not deliver active power in the “cease to energize” state. Additionally, reactive power exchange in the cease to energize state should be limited to 10% of the DER nameplate rating if the DER rating is <500 kVA, or 3% of the DER nameplate rating if the DER rating is  $\geq$ 500 kVA, and shall exclusively result from passive devices (IEEE Standard 1547.7). If the DER fails to cease to energize, it will have negative implications on the safety of personnel, the health of adjacent equipment, and the reliability of the DER.
- *Anti-islanding testing* verifies that the DER does not energize or remain energized when the system voltage and frequency are not within acceptable ranges. A failure of this test would have negative implications on the safety of personnel, the health of adjacent equipment, and the reliability of the DER.

- *Fault characterization testing* is important for the electrical interconnection because the fault current contribution from the DER can greatly affect the sensitivity and reliability of the power system protection system. Running these tests increases the safety of personnel and the health of adjacent electrical equipment.
- *Power quality testing* analyzes the characteristics of the power delivered to meet standard requirements. The specific tests include examining the DC injection current, rapid voltage change, flicker, current harmonic distortion, and voltage harmonic distortion. Adverse power quality could have consequences for the health of adjacent electrical equipment.
- *Testing for DER response to abnormal events and disturbances* is important for the safety of personnel, health of adjacent electrical equipment, the reliability of the DER, and the performance of the DER. Specific abnormal event tests for electrical interconnection include examining electrical faults (inside the DER and on the adjacent power system), open-phasing events, voltage disturbances, and frequency disturbances. Depending on the situation, the correct response of the DER may be tripping the DER completely or having the DER ride-through temporary abnormal events. Furthermore, for faults, in certain situations, the DER may be required to provide voltage support in the form of reactive power injection.
- *Voltage regulation and operating mode testing* is applicable.
- *Synchronization testing* verifies that the DER is paralleling with the area EPS without causing step changes exceeding 3% for medium voltage and 5% for low voltage (IEEE Standard 1547.7). Exceeding these values can harm the health of adjacent electrical equipment and decrease the reliability of the system by causing protective devices to trip.
- *Surge-withstand testing* verifies that the DER can withstand voltage and current surges as defined in IEEE Standards C62.41.2, C37.90.1, and C62.45, and IEC 61000-4-5, as applicable. The results of these tests can have implications for DER reliability, performance, and quality.
- *Electromagnetic interference testing* ensures that an electric field strength of 30 V/m or less does not affect the reliability or performance of the DER (IEEE Standard 1547.7).

#### **2.4.1.2 Advanced modeling and digital testing of electrical interconnection**

Modeling inverters in a power systems model can present many challenges. Inverters have been modeled as synchronous generators with a 1.1–1.5 p.u. fault current output; however, this does not capture all the inverter dynamics. Manufacturers now provide dynamic inverter files to help utility companies and developers more accurately model inverter behavior. Additionally, power system software companies are providing more features for inverter-based technologies in their products.

Previous attempts at analyzing dynamic behaviors of inverter-based resources were not feasible because of the lack of computing power. With advances in dynamic power system simulation programs, detailed and accurate digital testing of the electrical interconnection can be performed before physical testing. Modern transient simulation programs allow for detailed modeling of induction- and inverter-based generators for dynamic load flow, fault, and stability analysis. These studies find problems that would result with the hydropower generator connecting to the electrical grid, and these issues can be mitigated before commissioning.

### 2.4.1.3 Microgrid testing for hydropower resources

Microgrids are becoming more prevalent; they are small-power systems that operate in an islanding mode or act separate from the main grid and may be permanent or temporary depending on the situation. Without the grid source, a generator will have to act as the main source for the power system, and the generator can be rotating or inverter-based. The generator acting as the main source for the microgrid must have a constant power source, which may be plausible for constant run-of-river hydropower generators, hydropower pumped storage, or hydropower in conjunction with battery energy storage. Additionally, other generators that have an intermittent power source can be included to follow the main generator and reduce the energy storage requirement of the main source. Microgrids may be particularly important for using hydropower emerging technologies to help power isolated areas, such as islands, and local sections of the grid that get disconnected because of power system component failure.

The isolated power system (i.e., microgrid) can be dynamically modeled in a power system transient analysis program, and a black-start and islanding study could be performed. The black-start study simulates whether the generator can properly and safely start the system and includes an analysis of transformer energization, motor starting, and protection and coordination analysis. An islanding study is performed while the simulated system is energized and includes an analysis of breaker switching, capacitor switching, and large infrequent motor starting.

### 2.4.1.4 Power hardware-in-the-loop

Although the conventional large hydroelectric generator interconnections are typically tested using simulation and on-site testing, with emerging small-scale inverter-based hydroelectric technologies, physical testing may be possible in a lab setting using a hardware-in-the-loop method.

A power hardware-in-the-loop (PHIL) test bed method could more accurately simulate the hydropower generator's performance in a main grid or microgrid without causing safety concerns with personnel or expensive equipment. This test bed should accurately simulate control systems, varying dynamic loads, other generation sources, and grid devices. PHIL testing can simulate grid stiffness, voltage, and frequency. Emerging hydropower generators can be safely tested for their interaction with the grid and their response to grid events, such as faults or transient waveforms. The test bed should also be able to simulate the transition from main grid to islanded mode. This type of testing would help increase the reliability of the DER and reduce the effects of grid integration before testing the device on the actual grid.

When testing the controls and generator for hydropower, the generator would be connected to the control unit, a dynamometer<sup>44</sup> to act as the turbine, and a computer interface. The control unit would receive input from the model about the water levels and flow speed. The unit would then send control commands to produce power and maintain power quality. The power generated from the tests would be compared against the theoretical optimal power production, which is directly proportional to the cube of the water speed.

The Air Force Research Laboratory conducted experimental tests using PHIL with a high-speed generator (Langston et al. 2012). Similar to the given example, the physical components of the test include the dynamometer coupled to the generator, which is connected to the computer interface. A real-time digital simulator simulates the electromagnetic transients and sends control signals to the dynameter, the variable voltage source, and the generator. The setup illustrated by Langston et al. (2012) shows that the generator

---

<sup>44</sup> A dynamometer is a test apparatus for rotating machines that simultaneously measures torque and rotational speed so as to enable the calculation of instantaneous power output.

and the supporting components are physical devices, and the control signals and electrical grid are simulated. The testing of the generator begins with a spin test with no power produced to verify that vibrations were minimal and within the safety margins. Testing continues with open-circuit excitation tests and load bank tests. All these tests help show that the rectifier can operate at the high fundamental frequency, measuring the harmonic distortions, and maintain the proper voltage. Once the described tests are done to ensure safety, load testing is done with the generator to produce real power and highlight the capabilities and limitations. These results help with analyzing the potential effects the generator could have on the electrical interconnection in simulations and field tests.

#### **2.4.1.5 Underwater electrical interface considerations for testing**

Underwater electrical interfaces are highly subject to corrosion caused by water, salt, and biome. The reliability and performance of the DER and its components may significantly deteriorate even over a short period of time. Additionally, if the electrical interface is underwater, it could cause current leakage that could paralyze or otherwise harm humans and marine life even with minute amounts of current. Devices fitting these criteria must be tested to ensure that damage caused by corrosion (particularly saltwater), aquatic organisms, or adverse weather conditions cannot cause the device to leak current.

### **2.5 I&C**

I&C technology comprises the equipment that monitor and manage different variables in a system. These technologies are crucial for safe and efficient operation of the hydropower facility because they identify and address changes in normal operating conditions. Sensors that monitor water flow, water pressure, current, voltage, frequency, and temperature are some of the monitoring equipment used for hydropower. Control equipment such as relays, governors, and other devices are used to send commands that cause predetermined actions throughout a system.

I&C technology includes a variety of equipment, including the following:

- *Governor*: a device used to monitor and control the speed of a turbine
- *Protective relay*: a relay whose function is to detect defective lines or apparatuses or other power system conditions of an abnormal or dangerous nature and to initiate appropriate control circuit action
- *Current transformer*: a step-down transformer that lowers current to a measurable level
- *Potential transformer*: a step-down transformer that lowers primary voltage to a measurable level
- *Breaker*: a device that protects equipment from overcurrent and short-circuit damage by interrupting electrical current
- *Supervisory control and data acquisition (SCADA)*: a computer system that collects and analyzes real-time data from field equipment

With regard to the testing hydropower technology landscape, I&C technologies accommodate the design objectives in the following ways:

- *H&S*—the risk to humans during monitoring or maintenance of plant equipment and the identification of unsafe or abnormal working conditions
- *RRM*—the ability of the technology to achieve its desired function over the life of the project

- *ECF*—the resolution, range, and response time of the technology
- *EI*—the effects of I&C technologies on relevant environmental conditions, and the use of environmental monitoring technology (i.e., sensors)

Appendix A.5 provides an overview of conventional I&C testing.

### **2.5.1 Emerging I&C Technologies and Testing Needs**

The new and emerging technologies regarding the I&C of hydroelectric facilities revolve around distributed small hydropower designs, power electronic-based electrical interfaces (e.g., rectifiers, inverters, cycloconverters), cybersecurity, advanced environmental monitoring, automated testing, and other novel instrumentation.

#### **2.5.1.1 Distributed and small-scale hydropower**

Emerging hydropower technologies are focused on distributed and small-scale hydropower generation rather than traditional large hydropower facilities. These systems will require several changes in the testing of hydropower I&C, including the testing of multiple distributed hydropower generators, distributed hydropower in conjunction with other DERs, and smaller and lower unit instrumentation. Compared with large hydropower plants that have well developed standards and specifications, small and micro hydropower systems have few standards that address these new technologies. Therefore, hydropower expert groups are developing new testing standards to reflect the specific challenges faced by smaller hydropower plants.

Future testing capabilities will need to be able to accommodate the testing of the combined control for multiple small, electrically close hydropower generators. Additionally, as other emerging technologies, such as solar, wind, and battery storage, are being added to the system, conventional and emerging hydropower resources should be tested alongside these other technologies. Control systems for distributed hydropower, especially considering inverter-based generators, may require testing for reaction speed to changes in the power systems influenced by other renewables sources, especially wind and solar. A test facility will also need to accommodate instrumentation that measures smaller unit values. For example, because of the nature of saturation with current transformers, the current transformers used for smaller generators will need to be accurate for smaller currents.

#### **2.5.1.2 Testing of inverter controls and measurements**

Section 2.4.2 describes the emergence of inverter-based hydropower generators and electrical infrastructure. Along with the previously mentioned emergence of hybrid systems that colocate inverter-based resources such as small-scale solar, wind, and battery systems, hydropower I&C technologies must interface with and control inverter-based systems. IEEE 1547 outlines basic control capability requirements for inverters. Some of the requirements include the capability to quickly disable the DER, limit active power, and change control settings. Other control requirements are based on various operating modes. Voltage regulation and operating mode testing verifies that the inverter can operate in its intended mode and with sufficient voltage regulation if applicable. These tests have implications for the reliability and performance of the DER. Typical operating modes for inverters include the following:

- *Constant power factor operating mode*: The inverter operates with a fixed output power factor (typically in the range of 95% leading to 95% lagging) such that the reactive power output is proportional to the active power generated. The most common power factor used is unity; however, an interconnection may be required to operate at a specific power factor different from unity on a

case-by-case basis. For testing this operating mode, a test bed will require accurate measurement of reactive and active power, and the simulated grid source will need to be able to vary system voltage and frequency through normal steady-state and transient states.

- *Voltage-reactive (volt-var) operating mode:* The inverter reactive power is based on the distribution system voltage and will inject or absorb power based on the target voltage thresholds through a specified volt-var relationship. For testing this operating mode, a test bed will require accurate measurement of voltage, and the simulated grid source will need to be able to vary system voltage.
- *Active power–reactive power (watt-var) operating mode:* The inverter reactive power injection or absorption is based on the active power injection through a specified watt-var relationship. For testing this operating mode, a test bed will require varying the real power injection of the inverter and measuring the resulting reactive power.
- *Volt-watt operating mode:* The inverter limits active power output based on the distribution system voltage following a volt-watt relationship. The reactive power modes may be used in conjunction with this mode. For testing this operating mode, a test bed will require varying the grid source voltage and measuring the resulting active power output.
- *Constant reactive power mode:* The inverter maintains a constant reactive power injection or absorption independent from the active power output. For testing this operating mode, the simulated grid source will need to be able to vary grid parameters.

Inverters are equipped with measuring devices to determine the operating point and maximum yield. The measurement devices include current, voltage, efficiency (ratio of output power to input power). These internal measurements should be connected to the control system and tested for accuracy. The efficiency could be particularly difficult because it requires simultaneous high-precision measurements of the input and output power for the inverter. More information on measurement accuracy requirements is provided in IEEE 1547.

### 2.5.1.3 Cybersecurity testing

Cybersecurity for I&C systems is becoming increasingly important because of the increasing occurrences of remote cyberattacks on critical infrastructure. These attacks are becoming more severe and more frequent. Recent examples of cyberattacks on critical infrastructure include the Colonial Pipeline ransomware attack in May 2021, the attack on SolarWinds in December 2020, and the ransomware attack on the Norwegian energy company Volve that resulted in the shutdown of several hundred municipal water treatment facilities in May 2021.<sup>45</sup> Any control system that is not locally isolated from the greater network is vulnerable to these remote cyberattacks, which can include direct communication links or other external factors such as timing and location. Throughout the evaluation of the system, all inputs to the system and what could happen if an adversary was to have control of that input must be considered. Guidelines to consider for design of the system are provided in reference guides (Stouffer et al. 2015; Bartock et al. 2021). The MITRE ATT&CK model<sup>46</sup> is another tool that can help evaluate the overall system from a cyber-vulnerability perspective. Using this model will allow for evaluating the security based on real-world observations of adversary tactics and techniques. As more electrical interfaces are

---

<sup>45</sup> [https://csis-website-prod.s3.amazonaws.com/s3fs-public/211022\\_Significant\\_Cyber\\_Incidents.pdf?aEdoMUixpyx5OpU4dNevDfNSFfKraUgT](https://csis-website-prod.s3.amazonaws.com/s3fs-public/211022_Significant_Cyber_Incidents.pdf?aEdoMUixpyx5OpU4dNevDfNSFfKraUgT)

<sup>46</sup> <https://attack.mitre.org/>

being made through inverter-based generation, additional potential vulnerabilities need to be examined with respect to the control system, communication links, and any potential supply chain concerns.

#### **2.5.1.4 Advanced environmental monitoring**

Environmental monitoring technologies are important for validating the performance of environmental technologies, such as fish passageways, and assessing the performance of hydropower facilities before and after commissioning. Particularly for fish passage, these technologies aid site assessment by identifying what species are of concern, where they are, and when they are present. Advanced technologies aim to reduce the associated costs, improve the resolution and accuracy of measurements, and reduce the overall impacts of hydropower on local biota and ecosystems. An important consideration in environmental testing is the impact of the monitoring or testing process on the subject. For example, tagging for fish passage should limit stress on live samples to ensure realistic conditions. These technologies are useful for environmental studies required by the Federal Energy Regulatory Commission and other regulators during the licensing process. Environmental monitoring spans several technologies categories, each with their own standards, innovations, and testing needs, including the following:

- *Fish tagging and telemetry systems* are useful in upstream and downstream fish passage studies because they enable the tracking and capture of fish before and after interaction with hydropower technologies. A conventional example is balloon tags that are manually attached to fish and inflate after passage so they can be captured and studied. Innovative approaches leverage acoustic, radio, and other types of transponders with telemetry systems (e.g., antennas or automated vehicles) to track the fish digitally.
- *Fish collection systems and methods* enable the capture of species for use in studies and testing. Electrofishing, block netting, and fish traps are common examples. Innovations could enable less expensive, more efficient, and safer means of fish capture. New testing capabilities must ensure proper handling of live vertebrates according to the Institutional Review Board standards.
- *Environmental DNA* describes an emerging field that leverages the analysis of DNA in water samples to identify local species. Testing is needed for novel applications of this concept in the hydropower field.
- *Underwater acoustic sensors and imaging* enable the monitoring and measurement of physical processes underwater, such as sediment and fish passage. High-conductivity water and the noise of hydropower plants can make some types of sensing equipment, such as hydrophones, difficult in hydropower applications. However, innovative imaging technologies paired with intelligent software could provide useful insights into biological and geomorphological processes.
- *Water quality sensors* assess various characteristics of the water, including dissolved gas concentrations, sediment concentrations, nutrient concentrations, temperature, biological contamination, and many more. These technologies are well developed and are crucial for monitoring the operation and effectiveness of hydropower technologies. Innovations could target novel applications, such as greenhouse gas emissions from reservoirs, or could improve the effectiveness of these technologies.

#### **2.5.1.5 Automated testing of I&C for hydropower generators**

Historically, many of these systems are tested manually, and this testing is typically tedious and requires the generator to be shut down. For regular maintenance testing after commissioning, researchers are investigating new methods for automated testing. Automated testing could eliminate labor-intensive tasks,



provide an opportunity for more frequent testing, eliminate outages associated with manual testing, and eliminate risk to personnel. The existing methodology is to apply the automated testing of I&C systems to conventional, large hydropower facilities; however, automated testing systems should also be applied to smaller, distributed hydropower for the same reasons. Ultimately, automated testing would greatly decrease the risk to the H&S of testing personnel and increase the reliability of the I&C systems of hydropower DER.

#### **2.5.1.6 Testing of novel instrumentation for hydropower systems**

Emerging hydropower technology introduces new instrumentation that needs to be tested to verify the accuracy of the measurement and the quality of the instrument. Large hydropower plants that use a reservoir system were designed to operate at baseload conditions for long periods of time. The stable and predictable environment causes less strain on the generating unit to reduce maintenance issues and enable planned shutdowns. The need for continuous and automatic monitoring of the plant was unnecessary. However, with the introduction of more DERs on the power grid and the more prevalent usage of small hydropower systems, the environment is becoming more unpredictable and dynamic. The generators are expected to operate at various speeds and frequent shutdowns. In addition, smaller hydropower systems experience greater changes in water flow speeds causing more wear on equipment. In addition, with the usage of smaller units, the quantity of generating sites will become more of an issue as the probability of component failures increases.

Real-time water flow measurements are possible with modern data recording systems and may be more important with hydropower turbines designed for smaller flow volumes and intermittent water sources. Instrumentation that measures and the systems that record and store these real-time water flow measurements should be tested for accuracy and functionality with the conditions (including water speed) considered.

Digital twins are another novel area of innovation that pairs sensors with simulation models to predict equipment health and performance. By modeling physical systems with historical and real-time data, the digital twins can help optimize performance and make proactive maintenance decisions with limited outages. These tools can be applied across the physical design hierarchy, but the current research focuses on integrated powertrain and grid modeling for generation optimization. Testing of physical systems is crucial for validating the accuracy of the simulation models in real-time.

As emerging hydropower generators are being designed with novel composite and other structural materials, structural health monitoring of DERs is becoming increasingly important. The instrumentation that monitors the structural health of DERs must be tested to ensure accuracy and functionality since failures in this instrumentation could lead to decreased reliability and performance of the DER, as well as potential environmental impacts. Instrumentation for structural health monitoring could include temperature, vibration, pressure, and leakage sensors. Additional information is provided in ISO 13373-7:2017 and 19283:2020.

Many of the tests described for the controls and instrumentation in this report are short-term types of tests. The testing required for monitoring of vibrational anomalies or other types of faults is extended-duration testing. The hydropower plant should operate at expected power outputs, and it will need to do so for long periods of time. During the tests for controls or generation capability, the failure points of the device will be highlighted. These are used to determine the steady-state behavior of the hydropower system. Once this state is determined, the vibrational data that are collected from critical locations throughout the plant as it operates will show abnormalities when components begin to fail or if the water conditions are causing strain on the parts. Furthermore, depending on the spectral analysis of the waveforms, this data can provide insight into the underlying cause of the abnormal behavior in relation to a hydropower

component. For an effective condition monitoring system, various potential failure modes should be monitored as outlined in A.3 of ISO 19283. The failure modes relate to how the components of the hydropower system fail and include the generator and exciter, shaft and bearing assembly, penstock, runner, and draft tube. The effects of these failure are monitored with different techniques as outlined in Table 2 of ISO 19283. Instrumentation should be used to monitor the components to establish normal behavior and then, when abnormalities occur, the prototype design can be altered, or an operational plant can be shut down for maintenance.

As described in Section 2.4.2.4, hardware in the loop is a testing technique that allows for the interaction between physical devices and a simulated environment using a computer interface. A more specific type of this technique is control hardware-in-the-loop (CHIL), which is used for testing the input and output of data signals between the physical electrical device and the simulated environment. CHIL testing provides an interaction between varied time scale response of hydropower and other integrated technologies. Digital governors must be prototyped in a controlled real-world environment, including emerging SiC power electronics converters as grid interface for hydropower. CHIL also helps understanding communication interactions, interoperability, cyber-physical analysis and design, and next-generation communication such as low-earth orbit satellites (5G LEO). This testing could involve connecting the control unit to a computer that is running the model of a simulated generator. CHIL enhances the quality of tests and iterative development of hydropower control and power systems. Software such as Digital Real-Time Simulation is used to realistically represent the system dynamics. In the simulated environment, the water level or flow speed could be adjusted to any parameters within the expected range. The device can be tested quickly and over a wide range of values without the safety concerns or the time and cost of building a full-scale physical test that come with real water systems. In addition, a water testing facility may have limitations, and the hardware under test capabilities might not be fully tested. In contrast, the simulated model of a water test facility could be designed to thoroughly test any device. This is especially important for emerging technologies that can generate power from water flows that differs from conventional uses. Hardware in the loop can be used to accelerate the development process and allows for products to come to market more quickly.

### 3. TESTING CHALLENGES FOR HYDROPOWER INNOVATIONS

This section provides the rationale and analyses for discernment of emerging hydropower innovations and technologies that will require additional or enhanced capabilities or facilities to test, validate, and enable them to progress through a pathway from conceptualization to commercialization to deployment. This section introduces testing challenges for emerging hydropower innovations from which opportunities and alternatives are formed in Section 5. This evaluation includes the background and factors of the hydropower technology landscape and testing (Section 1) and the overview of technology and testing needs from across the landscape (Section 2).

The emerging technologies and innovations described in Section 2 were compiled to demonstrate the innovation trends and examples of hydropower innovations, as listed in Table 2. Specific inventions or innovations (for example, a patentable device or a new control scheme) can be categorized into one or more of these trends or, if necessary, a new trend/innovation can be accommodated by the rationale that follows. The hydropower innovations are categorized by the physical design hierarchy in the rows of Table 2 (i.e., powertrain, conveyance, structures, electrical interconnections, and I&C). However, each particular invention or innovation has a footprint (i.e., dependencies, effects, or influences) across a host of constraints, including the four main design objectives introduced in Section 1.4 (H&S, RRM, ECF, and EI). Therefore, each invention or innovation must be validated against each design objective, thus engendering the type of specific testing and validation required. These requirements are communicated by specifying the combinations of test factors, as described in Section 1.4 (scale, water condition, system completeness, variance of ambient conditions, and response characterization), that are necessary during testing to yield results that may be used to validate the innovation.

Answering the question of how design objectives and constraints invoke testing requirements and engender test factors is typically a shared responsibility of technology developers, product engineers, test engineers, and subject matter experts with knowledge of and experience with the specific innovation or its proposed or target application. The test plans and test results they produce must be amenable to analyses, summary, and reporting that are acceptable and sufficient to validate the technology for investors, first adopters, natural resource stewardship agencies, regulators, and others invested in the outcomes of deploying the technology (Section 1.2).

As a surrogate for invention-specific testing plans and programs that provide very detailed testing requirements in a specific case, Section 3.1 provides tables of validation questions as an example for a selected innovation in each of the five physical design categories. Considering the testing necessary to answer those questions leads to several combinations of test factors that must be provided by existing or new testing facilities (as highlighted at the end of each example). Section 3.2 ties together recurring testing thematic challenges that emerged from the analysis of these testing and innovation trends, the specific examples of Section 3.1, and the evaluation of the responses collected from the WPTO RFI (Appendix C provides more details) that informed this report.

**Table 2. Hydropower innovations compiled from Section 2.** Boldface, italicized text within the Example innovations column indicate the examples used for validating questions in Section 3.1

Physical design hierarchy	Hydropower testing and innovation trends (identified in Section 2)	Example innovations
Powertrain	<ul style="list-style-type: none"> <li>• Turbine design innovations</li> <li>• Generation innovations and flexibility</li> <li>• Environmental testing</li> <li>• Advanced materials and manufacturing</li> </ul>	<ul style="list-style-type: none"> <li>○ Runner components made of composite materials</li> <li>○ <b><i>Fish-friendly turbines</i></b></li> <li>○ Small modular turbines</li> <li>○ Aerating turbines</li> <li>○ Variable speed machines</li> <li>○ Converter-fed synchronous machine and doubly fed induction machine</li> <li>○ Permanent magnet generators</li> <li>○ Magnetic gears powertrains</li> <li>○ In-line turbines for urban water systems</li> <li>○ Environmentally acceptable lubricants</li> </ul>
Conveyances	<ul style="list-style-type: none"> <li>• Water conveyances</li> <li>• Fish conveyances</li> <li>• Sediment conveyances</li> <li>• Boat conveyances</li> <li>• Retrofits and modular designs</li> <li>• Changing conditions</li> </ul>	<ul style="list-style-type: none"> <li>○ Penstocks made in composite materials</li> <li>○ Volitional fishway designs</li> <li>○ <b><i>Sediments bypass</i></b></li> <li>○ Whitewater park structures</li> <li>○ Aerating weirs and downstream structures</li> <li>○ Advanced linings</li> <li>○ Flow measurement devices</li> </ul>
Structures	<ul style="list-style-type: none"> <li>• Advanced concrete technologies</li> <li>• Modular superstructures</li> <li>• Geotechnical innovations</li> <li>• Innovative storage systems</li> </ul>	<ul style="list-style-type: none"> <li>○ <b><i>Concrete printing</i></b></li> <li>○ Prefabricated concrete and formwork</li> <li>○ Modular foundations</li> <li>○ Floating reservoirs</li> </ul>
Electrical interconnection	<ul style="list-style-type: none"> <li>• Inverter-based interconnection</li> <li>• Advanced modeling and digital testing</li> <li>• Microgrid designs for hydropower</li> <li>• PHIL testing</li> <li>• Underwater electrical interfaces</li> </ul>	<ul style="list-style-type: none"> <li>○ Digital twins</li> <li>○ Small hydropower energy converters</li> <li>○ Black start systems</li> <li>○ Microgrid designs</li> <li>○ <b><i>PHIL</i></b></li> </ul>
I&C	<ul style="list-style-type: none"> <li>• Distributed and small-scale hydropower</li> <li>• Inverter control testing for hydropower</li> <li>• Cybersecurity testing</li> <li>• Advanced environmental monitoring</li> <li>• Automated testing</li> <li>• Novel instrumentation</li> </ul>	<ul style="list-style-type: none"> <li>○ Embedded sensors for smart components</li> <li>○ Structural health monitors</li> <li>○ <b><i>Biomimetic fish sensors</i></b></li> <li>○ Fish tracking sensors and telemetry</li> <li>○ Flow-tracking (Lagrangian) sensors and telemetry</li> <li>○ Sediment monitoring</li> <li>○ Hybrid (hydropower and other) system controls</li> </ul>

### 3.1 TECHNOLOGY AND INNOVATION VALIDATION QUESTIONS

Validation questions in the context of this report express the expected functionality for an innovation or new technology in terms of design objectives and constraints that will be important to stakeholders who make or influence a series of decisions to advance a technology from concept to commercial deployment. Technology developers and testing specialists would then translate these questions into a test plan that specifies the combinations of test factors necessary to answer the question. An important aspect of the set of validation questions for an innovation trend is that they address more than the primary design

objective; they must also address secondary objectives and design constraints, some of which may be implicit and not obvious to inventors or technology developers unfamiliar with hydropower design and operations.

The test factors introduced in Section 1 provide the structure to translate validation questions into specifications for testing. Figure 4 illustrates a set of 72 unique combinations of test factors that are possible given the test factors of scale, water condition, system completeness, ambient time variance, and response. For example, one may specify a “model-scale, dry, component, steady-state, static response” testing arrangement as a first step in validating a nascent technology, whereas a “full-scale, flow-through, complete, time-varying, dynamic response” testing arrangement would be more appropriate for a technology on the verge of commercialization (which may also need a testing arrangement that provides significant “runtime” to convince first adopters of its commercial viability). In general, testing pathways toward the left of the figure represent less expensive and earlier-stage (lower TRL) testing activities, whereas testing pathways toward the right of the figure represent more expensive and later-stage (higher TRL) testing activities. Figure 4 is representative of the vast test factors that influence hydropower technology innovation. Inclusion of additional factors and additional capabilities for each factor would expand the pathways and increase the number of testing combinations available to address the validation questions for a technology innovation, but the rationale would remain the same as that presented herein.

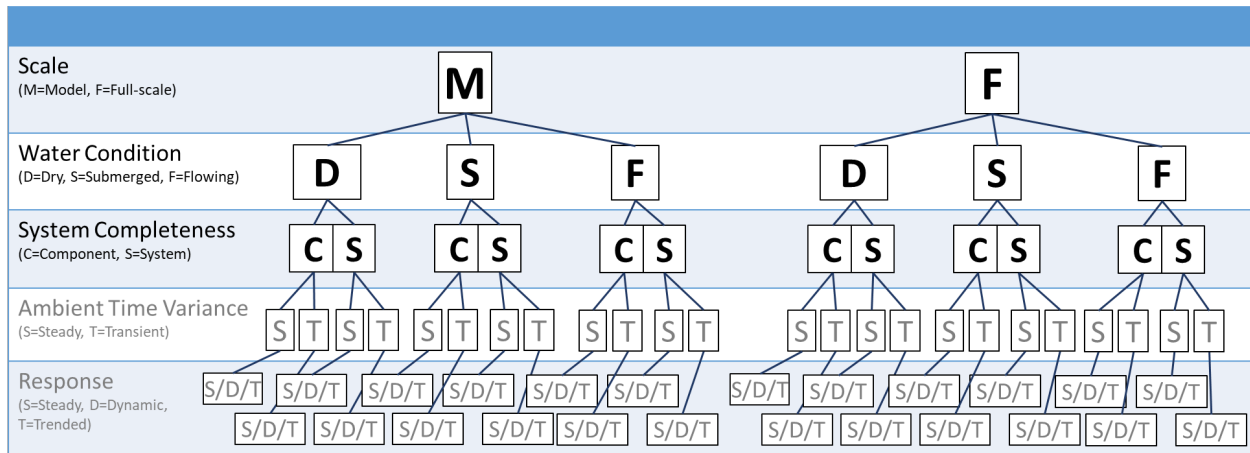

**Figure 4. The test factor testing pathways that follow from the five test factors defined in Section 1.** As introduced in Section 1.4, scale: model (M) and full scale (F); water condition: dry (D), submerged (S), and flow-through (F); system completeness: component (C) and system (S); ambient time variance: steady (S) and transient (T); response: steady (S), dynamic (D), and trended (T).

Implicit within Figure 4 is an ordering of test factors that prioritizes scale, water condition, and system completeness in decreasing significance for the type of facility that would be needed to accomplish testing. In other words, when identifying test facilities that will be required to validate an innovation, the most important factor to consider is whether testing and validation can be done at model scale or full scale, followed by whether testing and validation could be done in dry, submerged, or flow-through conditions. Next, one would consider whether testing with the complete system or just the innovative component would be required. Some technologies would require testing in several of these combinations of test factors to progress from conceptualization to commercial viability. The capabilities to expose innovative technology prototypes to ambient time variance or to characterize the dynamic or trending response of a technology prototype during testing are important considerations, but they are usually factors of testing equipment, instrumentation, controls, and schema needed within a facility, and are secondary to the factors of testing scale, water condition, and system completeness. Specific potential

combinations of test factors are highlighted for each innovation example to unveil all the capabilities that must be provided by existing or new testing facilities.

### **3.1.1 Powertrain Technology Example: Fish-Friendly Turbines**

Table 3 provides an example of a set of validation questions for a turbine prototype with a primary objective of passing a particular species of fish without injury. The questions in Table 3 are representative and may not be comprehensive; a technology developer must assemble a robust and technology-specific set of questions based on specified design objectives and application context for the technology. In this example, the questions convey the expectation that the turbine must also avoid introducing new hazards to public and worker H&S. The turbine response under the full range of operations expected must be analyzed to ensure that any new modes of failure for the turbine itself, or any failure modes the new turbine design may create in other components, are analyzed for probability and consequence, tested if necessary, and addressed with hazard controls, operating constraints, and design changes. Validating analyses of the RRM of the fish-friendly turbine may require extended duration testing, including special attention to the RRM of innovative geometries and mechanisms that make the turbine fish-friendly. The ECF design objectives for the fish-friendly turbine not only require validation of energy conversion ECF, but also those of successful fish passage over a range of hydraulic conditions. Energy performance and fish passage performance may need to be tested under conditions of up-ramping, down-ramping, condensing, and frequent start-up and shutdown to validate the flexibility of the turbine design. Finally, in the EI category, a fish-friendly turbine may need to be validated for multiple species of fish and for stressors other than direct injury (e.g., strike or barotrauma) during turbine passage, with attention to how spatial and temporal variations of water quality and other ambient conditions may affect success.

The testing factor combinations columns of Table 3 indicate how each validation question invokes test factors and conditions necessary to provide results that answer the question. The final column in the table provides a preliminary rationale for the particular combination of test factors indicated. Figure 5 combines all the test factors listed for fish-friendly turbines for the limited list of exemplary questions and highlights in green shading the potential testing pathways required.

**Table 3. Validation questions, test factor combinations, and rationale for the fish-friendly turbine innovation example.** Testing factor combination abbreviations—scale: model (M) and full scale (F); water condition: dry (D), submerged (S), and flow-through (F); system completeness: component (C) and system (S); ambient time variance: steady (S) and transient (T); response: steady (S), dynamic (D), and trended (T)

Design objective category	Validation question	Testing factor combinations					Rationale
		Scale	Water condition	System completeness	Ambient time variance	Response	
H&S	Does the fish-friendly design innovation produce hazards or potential failure modes relative to installed designs?	M	F	*	*	*	Some H&S hazards associated with assembly, installation, and operation can be inferred during scaled physical model tests in flowing water conditions.
		F	F	S	*	*	Some aspects of H&S during assembly, installation, and operation can only be discerned at full scale in near-deployment conditions.
	Does the fish-friendly design innovation produce new hazards or new potential failure modes in other components?	M	F	S	*	*	Some aspects of H&S during assembly, installation, and operation can be inferred during model-scale tests of innovated and related components.
		F	F	S	*	*	Some aspects of H&S during assembly, installation, and operation can only be discerned at full scale in near-deployment conditions.
RRM	Do fish-friendly design features affect the RRM of energy and services from the associated hydropower asset?	M	F	*	*	*	Some aspects of RRM of innovative turbines and components can be tested at model scale.
		F	F	*	*	*	Most hydropower asset owners (potential buyers) request an extended-duration (long-runtime) demonstration of full-scale efficacy.
	What issues may degrade the long-term RRM of successful fish passage?	M	F	*	*	*	Some functions of fish passage technology may be addressed through accelerated wear testing at model scale.
		F	F	*	*	*	Most hydropower asset owners request an extended-duration (long-runtime) demonstration of full-scale efficacy.

**Table 3. Validation questions, test factor combinations, and rationale for the fish-friendly turbine innovation example (continued)** Testing factor combination abbreviations—scale: model (M) and full scale (F); water condition: dry (D), submerged (S), and flow-through (F); system completeness: component (C) and system (S); ambient time variance: steady (S) and transient (T); response: steady (S), dynamic (D), and trended (T)

Design objective category	Validation question	Testing factor combinations					Rationale
		Scale	Water condition	System completeness	Ambient time variance	Response	
ECF	How do fish-friendly design features affect ECF of generation?	M	F	S	S	D	Most turbine mechanical performance characteristics can be tested at model scale (guided by appropriate standards such as IEC 60193) and then be scaled up to estimate prototype performance.
		F	F	S	*	*	For some features of performance, some potential adopters may opt for validation at full scale (similar to acceptance testing).
EI	Which fish species are passed with success?	F	F	S	*	D	Regulatory and resource agencies and other stakeholders will ultimately need proof of full-scale live fish passed without injury through full-scale turbines at rated flow and head conditions, and even under turbine start-up, ramping, shutdown, and other transient conditions.
		F	F	C	*	D	Some testing of interactions with fish can be done at full scale with turbine components in laboratory flumes. Other flume tests to characterize behavior and capability of selected fish species may be required.
		F	S	C	*	D	Some fish strike testing and barotrauma testing can be performed at full scale with turbine components in static tanks in laboratories.
		M	F	S	*	D	Early-stage component (blade and gate) shapes to produce fish-friendly hydrodynamics can be refined in computational models and validated with scaled physical models.

Notes: An asterisk (\*) indicates that testing under all possible alternatives for the indicated test factor is likely to be useful. For example, an asterisk listed for water condition indicates that useful testing is beneficial with dry, submerged, and flow-through conditions. The letters used for the testing factor combinations are defined in Figure 4.



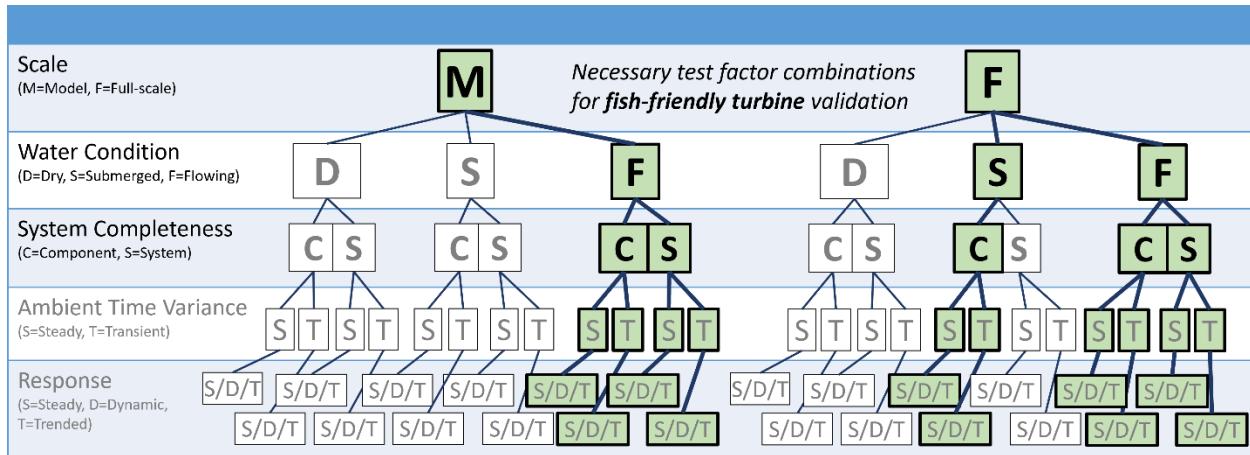

**Figure 5. The test factor pathways of the fish-friendly turbine innovation example.** Green shading highlights the potential testing pathways required.

### 3.1.2 Conveyance Technology Example: Sediment Conveyance for Geomorphic Connectivity

Table 4 provides an example of a set of validation questions for a proposed technology with a primary objective of maintaining or restoring geomorphic connectivity and transport functionality of a stream in which a dam has been constructed. In other words, the proposed technology would enable the appropriate sizes and concentrations of sediment particles to bypass the dam such that the geomorphic effects of the dam on the stream are confined to a very limited forebay and tailrace region immediately adjacent to the dam (for example, the University of Minnesota hydrosuction approach that was awarded DOE funding<sup>34</sup>). As with the powertrain example, validation questions arise from each of the design objective categories.

The questions in Table 4 are representative and may not be comprehensive; a technology developer must assemble a robust and technology-specific set of questions based on specified design objectives and application context for the technology. For this example, failure could occur if sediments are not conveyed and flushed downstream correctly; unforeseen accumulation of sediments downstream of the turbine could be detrimental for the structural safety of the facility. All potential mode of failures must be analyzed and addressed with operation constraints and design modifications. Tests to assess RRM and ECF will likely require analysis and validation at full scale for extended durations. Tests at model scale cannot always be used when simulating sediment transport because the technology geometric scaling may lead to impractically fine grain sizes that may present cohesive effects that are not representative of the sediment behavior at full scale. Furthermore, friction and abrasive forces are typically difficult to scale up for material resilience assessment analysis. Long experiments may be required in consideration of the fluctuating and intermittent nature of sediment transport, which follows flood intensities and time scale. The reliability and performance of the sediment passage technology will thus require dynamic and trended measurements for extended durations. Finally, EI will likely require full-scale validation to ensure the safe interaction between the technology and the surrounding biota (e.g., fish) and evaluate how water quality and varying ambient condition may affect performance.

**Table 4. Validation questions, test factor combinations, and rationale for the sediment passage innovation example.** Testing factor combination abbreviations—scale: model (M) and full scale (F); water condition: dry (D), submerged (S), and flow-through (F); system completeness: component (C) and system (S); ambient time variance: steady (S) and transient (T); response: steady (S), dynamic (D), and trended (T)

Design objective category	Validation question	Testing factor combinations					Rationale
		Scale	Water condition	System completeness	Ambient time variance	Response	
H&S	Are there failure modes and hazards associated with the innovative sediment passage functionality?	M	*	*	*	*	Some H&S hazards associated with assembly, installation, and operation can be inferred during scaled physical model tests in submerged or flowing water conditions.
		F	F	S	*	*	Some aspects of H&S during assembly, installation, and operation can only be discerned at full scale in near-deployment conditions.
	Do sediment handling innovations induce failure of adjacent components of a hydropower facility (for example, does sediment accumulate in unexpected ways to produce unexpected forces on components)?	M	F	*	*	*	Some H&S hazards and mitigations associated with assembly, installation, and operation can be inferred during scaled physical loose-bed model tests; for example, sediment dynamics and accumulation can be tracked using laboratory experiments.
		F	F	S	*	*	Some aspects of H&S and mitigations during assembly, installation, and operation can only be discerned at full scale in near-deployment conditions since some forces and failure modes cannot be easily scaled up from model testing (e.g., frictions, erosion).
RRM	How robust is the sediment handling innovation with respect to clogging, erosion, and other failure mechanisms?	M	F	*	*	*	Some RRM aspects of innovative sediment handling can be tested at model scale; clogging, erosion, and other failure mechanisms can be simulated in laboratory experiments and require flow-through conditions for both components (e.g., inlet, pipe) and complete systems. This test may require an extended duration of testing with different combinations of time variance and response characterizations.
		F	F	*	*	*	Validation of the RRM of the sediment passage technology may require extended-duration testing in sediment laden flows at full scale to understand how sediment passage may erode or damage components and degrade the capability to convey (i.e., pass) the necessary particle sizes.

**Table 4. Validation questions, test factor combinations, and rationale for the sediment passage innovation example (continued).** Testing factor combination abbreviations—scale: model (M) and full scale (F); water condition: dry (D), submerged (S), and flow-through (F); system completeness: component (C) and system (S); ambient time variance: steady (S) and transient (T); response: steady (S), dynamic (D), and trended (T)

Design objective category	Validation question	Testing factor combinations					Rationale
		Scale	Water condition	System completeness	Ambient time variance	Response	
RRM	Does the sediment handling innovation remain functional during extreme events (e.g., flood, drought) or return to service afterward?	M	F	*	*	*	Some RRM aspects of innovative sediment handling can be tested at model scale; transient sediment transport capacity can be simulated at the laboratory scaled so that several combinations of time variance and response characterization can be evaluated.
		F	F	*	*	*	Validation of the RRM of the sediment passage technology may require testing or demonstration in extreme flows (of water and sediment) at full scale.
ECF	Does the sediment handling innovation handle time-varying incoming mixtures of grain sizes (e.g., fine silt to cobbles)?	F	F	*	T	*	Geometrical scaling of grain size may introduce challenges making it difficult to simulate effectively transport of mixtures at model scale (and also difficult to characterize in situ). Transport efficiency will have to be evaluated at full scale.
	What sensing, control, automation, and/or operator intervention are required for continuous efficacy?	M	F	*	*	*	Conveyance operation might be automated or manually operated depending on the level of sensed sediment transport conditions. Sensors and operating plans can be designed and tested at model scale using flow-through experiments. Results may help integrate sensors and operating plans within the design process.
		F	F	*	*	*	Some measurement techniques and sensors used at laboratory scales cannot be employed directly at field scale. Different sensors and monitoring techniques might be required at full scale (and flow-through).
	How would fluctuations of turbine flows or other bypass flows affect the efficacy of the innovation?	M	F	*	T	*	Different components that affect and are affected by flow fluctuations (e.g., turbines, spillways, sediment passage modules) can be simulated through scaled laboratory experiments to assess the interdependency. Powertrains and hydraulic and sediment conveyances models will have to obey the same scaling laws, and flow-through is required. Combination of different time variance conditions and response characterizations may be required.

**Table 4. Validation questions, test factor combinations, and rationale for the sediment passage innovation example (continued).** Testing factor combination abbreviations—scale: model (M) and full scale (F); water condition: dry (D), submerged (S), and flow-through (F); system completeness: component (C) and system (S); ambient time variance: steady (S) and transient (T); response: steady (S), dynamic (D), and trended (T)

Design objective category	Validation question	Testing factor combinations					Rationale
		Scale	Water condition	System completeness	Ambient time variance	Response	
		F	F	*	T	*	The modeled interdependency might not scale up correctly, and coordinated testing of different technologies at full scale may be needed to assess the actual efficiency of the innovation.
EI	How might the innovation affect biota upstream, downstream, or passing through the facility/module?	F	F	*	*	*	Validation of the EI of the sediment passage technology will require full-scale testing to assess the safe interaction with biota (e.g., fish and other aquatic animals).
	Which hydraulic, water quality, and ambient conditions (e.g., icing) enhance or degrade sediment passage efficacy?	M	F	*	*	*	Interaction with ambient conditions, water quality, and varying hydraulics can be simulated at laboratory scales while monitoring the sediment passage efficacy. This will require flow-through, steady-state and transient conditions, and a combination of different response characterizations.
		F	F	*	*	*	The same hydraulic, water quality, and ambient conditions simulated at model scale might need to be monitored at full scale to validate the actual sediment passage efficacy.

Notes: An asterisk (\*) indicates that testing under all possible alternatives for the indicated test factor is likely to be useful. For example, an asterisk listed for water condition indicates that useful testing is beneficial with dry, submerged, and flow-through conditions. The letters used for the testing factor combinations are defined in Figure 4.

The testing factor combinations columns of Table 4 indicate how each validation question invokes test factors and conditions necessary to provide results that answer the question. The final column in the table provides a preliminary rationale for the particular combination of test factors indicated. Figure 6 combines all the test factors listed for sediment passage technologies for the limited list of exemplary questions and highlights in green shading the potential testing pathways required.

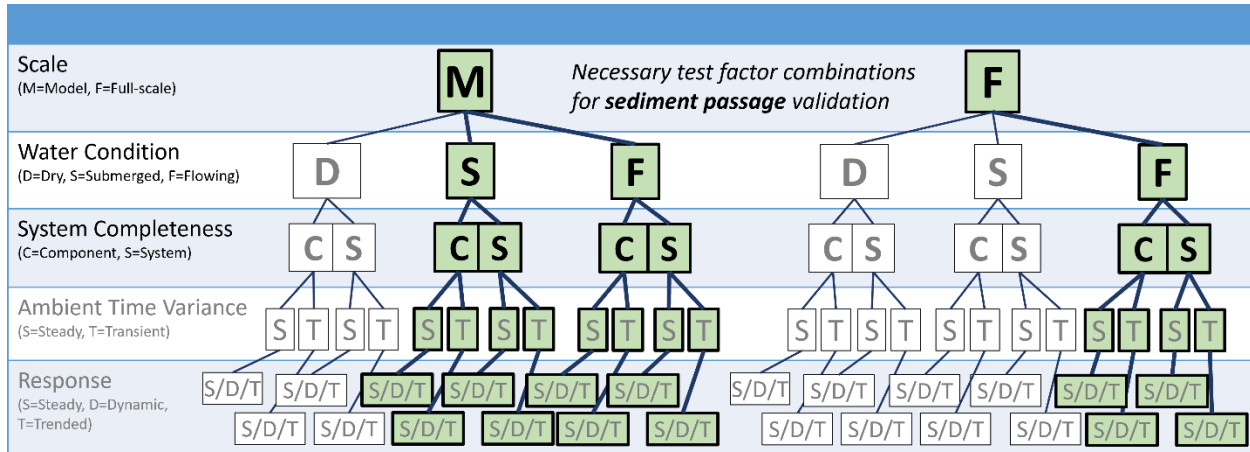

**Figure 6. The test factor pathways of the sediment passage innovation example.** Green shading highlights the potential testing pathways required.

### 3.1.3 Structural Technology Example: Concrete Printing for Hydraulic Structures

Table 5 provides an example of a set of validation questions for a technology that would enable large area, in situ printing of concrete structures. The primary objective of this technology is to manufacture reliable and resistant structures (e.g., foundations, walls, parts of the dam, conveyances) with rapid additive manufacturing technologies that may offer cost and time savings. The questions in Table 5 are representative and may not be comprehensive; a technology developer must assemble a robust and technology-specific set of questions based on specified design objectives and application context for the technology. Structural stability is a fundamental design objective, along with long-term resiliency and durability. Considering the catastrophic implications of a hydropower facility structural failure, H&S and RRM analyses are paramount. Material characteristics can be tested on specimens in the dry in laboratory settings, whereas preliminary design configurations may involve testing at model scale to evaluate efficacy and refine designs. However, the final validation of a printed concrete structure that is ready for deployment may require demonstration at full scale and in some combination of hydraulic conditions (immersed or flow-through). Concrete printing application to hydropower structures is highly unconventional and is potentially risky. Therefore, almost all the test factors will likely need to be pursued to validate its use. Table 5 provides some validation questions that arise from the design objectives, but they are not intended to be comprehensive. A technology developer must assemble a robust and technology-specific set of questions based on specified design objectives and application context for the technology.

**Table 5. Validation questions, test factor combinations, and rationale for the concrete printing for hydraulic structures innovation example.** Testing factor combination abbreviations—scale: model (M) and full scale (F); water condition: dry (D), submerged (S), and flow-through (F); system completeness: component (C) and system (S); ambient time variance: steady (S) and transient (T); response: steady (S), dynamic (D), and trended (T)

Design objective category	Validation question	Testing factor combinations					Rationale
		Scale	Water condition	System completeness	Ambient time variance	Response	
H&S	What hazards and failures are associated with the erection and operation of on-site large-scale concrete printing systems in riverine environments?	F	*	S	*	*	Preliminary full-scale testing/demonstration can be done in controlled conditions away from actual riverine sites.
		F	F	S	*	*	Validation of ready-for-deployment systems may require demonstration at a riverine site where flow water conditions must be managed.
RRM	What are the ranges of material properties (modulus and strength) of printed concrete components?	M	D	C	S	S	Basic testing of printed specimens can be conducted in existing laboratories.
		M	S	C	S	S	Basic testing of specimens printed in submerged conditions can be conducted in existing laboratories.
		M	F	C	T	T	Printed specimens may need to be monitored for degradation of properties in flowing conditions in the laboratory.
	What is the initial and long-term efficacy of printed concrete components of hydraulic structures?	M	*	S	*	*	Some aspects of printed component structural performance and adequacy can be evaluated at model (partial) scale.
		F	F	S	*	*	Some aspects of printed component structural performance and adequacy must be demonstrated in situ at full scale and in extended-duration tests.
ECF	Does in situ printing of concrete components of hydraulic structures provide greater functionality of shape and surface than conventional methods?	M	*	*	*	*	Some aspects of printing complex shapes and surfaces can be tested at model scale.
		F	*	*	*	*	Some aspects of large component shapes and surfaces must be demonstrated at full scale.
EI	Does printing of components of hydraulic structures pose risks to the environment?	M	*	*	*	*	Many types of environmental testing for printed components can be conducted in a laboratory setting (e.g., leaching, erosion, toxicity).
		F	F	*	*	*	Some aspects of installation of printing systems, printing of components, and related construction activities may require field demonstration and environmental monitoring.

Notes: An asterisk (\*) indicates that testing under all possible alternatives for the indicated test factor is likely to be useful. For example, an asterisk listed for water condition indicates that useful testing is beneficial with dry, submerged, and flow-through conditions. The letters used for the testing factor combinations are defined in Figure 4.

The testing factor combinations columns of Table 5 indicate how each validation question invokes test factors and conditions necessary to provide results that answer the question. The final column in the table provides a preliminary rationale for the particular combination of test factors indicated. Figure 7 combines all the test factors listed for concrete printing for the limited list of exemplary questions and highlights in green shading the potential testing pathways required.

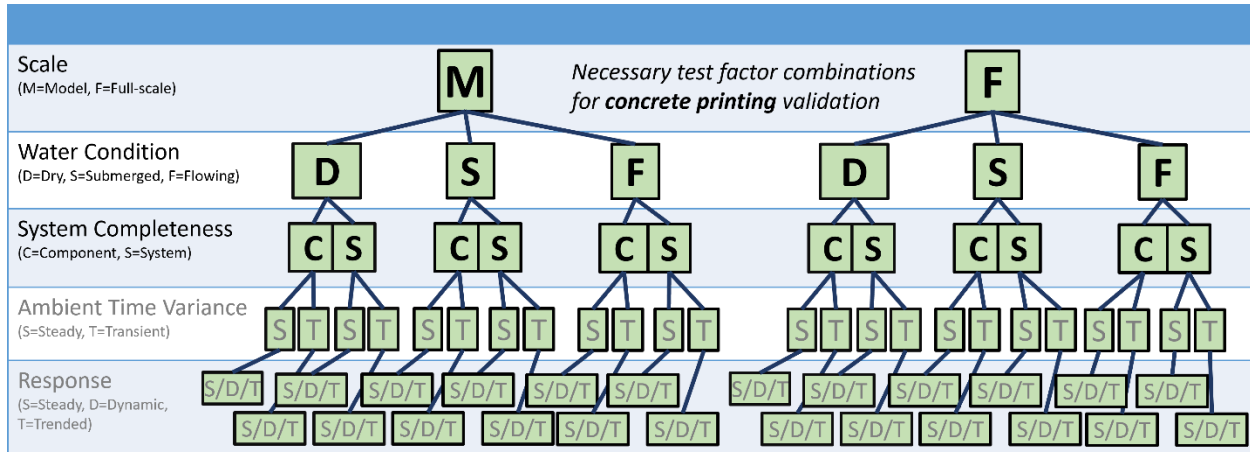

**Figure 7. The test factor pathways of the concrete printing innovation example.** Green shading highlights the potential testing pathways required.

### 3.1.4 Electrical Interconnection Example: PHIL

PHIL is an approach used to safely assess generator performance with respect to its response to and interaction with the grid. Controls and dynamic loading conditions of the turbine runner and grid can be simulated in a controlled manner to inform performance, reliability, and durability decisions before being installed on the actual grid. Table 6 provides an example of a set of validation questions for the proposed PHIL technology with a primary objective of safely and accurately testing generator interaction and response to a variety of loading conditions on the grid side and the turbine runner side. The questions in Table 6 are representative and may not be comprehensive; a technology developer must assemble a robust and technology-specific set of questions based on specified design objectives and application context for the technology.

**Table 6. Validation questions, test factor combinations, and rationale for a PHIL innovation pathway.** Testing factor combination abbreviations—scale: model (M) and full scale (F); water condition: dry (D), submerged (S), and flow-through (F); system completeness: component (C) and system (S); ambient time variance: steady (S) and transient (T); response: steady (S), dynamic (D), and trended (T)

Design objective category	Validation question	Testing factor combinations					Rationale
		Scale	Water condition	System completeness	Ambient time variance	Response	
H&S	Does the PHIL setup using a dynamometer provide safety to personnel beyond that associated with the use of a water flow-driven turbine?	F	D	*	*	*	Use of a dynamometer as opposed to flowing water and a turbine supports/promotes a safer testing environment for assessing turbine, generator, and grid interaction.
RRM	Does the PHIL setup provide any meaningful data and information for predicting RRM of a generator?	F	D	*	*	*	Different loading conditions imposed on the generator from the grid side and the turbine side can be beneficial for assessing RRM of a generator. This provides a highly controlled environment in which various scenarios for loading can be simulated without the complications and challenges associated with flow infrastructure (e.g., pressure head, water, turbine runner, catchment and recirculation).
	In a PHIL setup using the dynamometer as a turbine simulator, can responses of the generator provide any meaningful insight for RRM requirements for a hydropower turbine runner?	F	D	*	*	*	Whereas loading conditions can be specified with respect to water conditions and so on, there may be merit in assessing the effect of grid feedback and other factors on the coupled system to include not only the generator but also the runner. Information gained can serve as inputs to a different modeling or assessment approach used to address RRM of the turbine runner. Although the turbine runner is not physically included in the experiment, some useful information could be gained and used to inform a separate and different testing methodology.

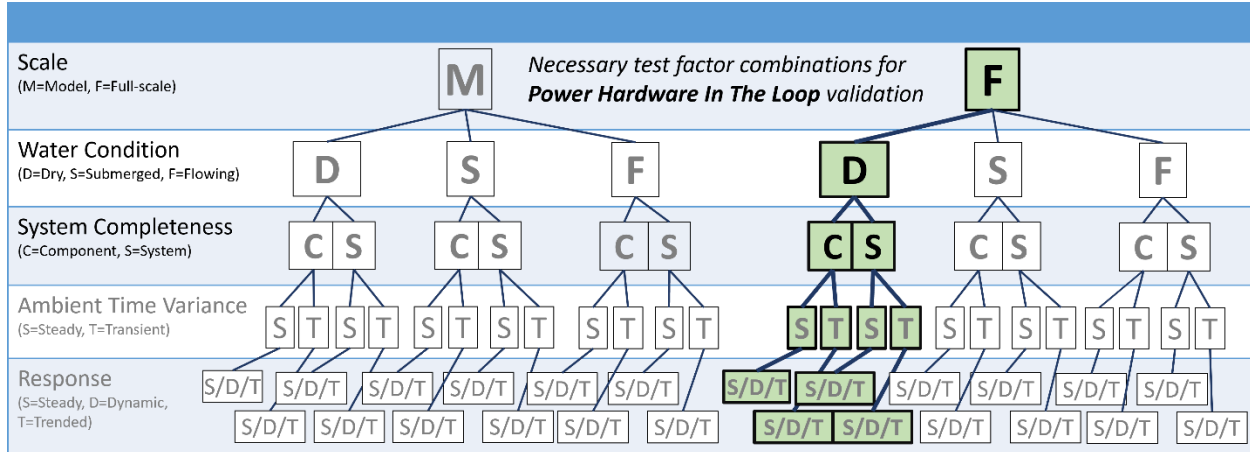

**Table 6. Validation questions, test factor combinations, and rationale for a PHIL innovation pathway (continued).** Testing factor combination abbreviations—scale: model (M) and full scale (F); water condition: dry (D), submerged (S), and flow-through (F); system completeness: component (C) and system (S); ambient time variance: steady (S) and transient (T); response: steady (S), dynamic (D), and trended (T)

Design objective category	Validation question	Testing factor combinations					Rationale
		Scale	Water condition	System completeness	Ambient time variance	Response	
ECF	Can the PHIL setup provide any meaningful data and information for predicting ECF of a generator?	F	D	*	*	*	Different loading conditions imposed on the generator from the grid side and the turbine side can be beneficial for assessing the ECF of a generator. This provides a highly controlled environment in which various scenarios for loading can be simulated without the complications and challenges associated with flow infrastructure (e.g., pressure head, water, turbine runner, catchment and recirculation)
	In a PHIL setup using the dynamometer as a turbine simulator, can responses of the generator provide any meaningful insight for requirements for ECF a hydropower turbine runner?	F	D	*	*	*	Whereas loading conditions can be specified respect to water conditions and so on, there may be merit in assessing the effect of grid feedback and other factors on the coupled system to include not only the generator but also the runner. Information gained can serve as inputs to a different modeling or assessment approach used to address ECF of the turbine runner. Although the turbine runner is not physically included in the experiment, some useful information could be gained and used to inform a separate and different testing methodology.

Notes: An asterisk (\*) indicates that testing under all possible alternatives for the indicated test factor is likely to be useful. For example, an asterisk listed for water condition indicates that useful testing is beneficial with dry, submerged, and flow-through conditions. The letters used for the testing factor combinations are defined in Figure 4.

The testing factor combinations columns of Table 6 indicate how each validation question invokes test factors and conditions necessary to provide results that answer the question. The final column in the table provides a preliminary rationale for the particular combination of test factors indicated. Figure 8 combines all the test factors listed for PHIL for the limited list of exemplary questions and highlights in green shading the potential testing pathways required.



**Figure 8. The test factor pathways of the PHIL innovation example.** Green shading highlights the potential testing pathways required.

### 3.1.5 I&C Example: Biomimetic Fish Sensors

Table 7 provides an example of a set of validation questions for Biomimetic fish sensors. These sensors are an example I&C innovation that aim to capture data on hydraulic conditions and impact characteristics of fish during turbine passage. Researchers at ORNL have created a biomimetic fish sensor, Gelfish, by additively manufacturing a mold of a scanned fish and using ballistic gel and surrogate skin with embedded sensors to create realistic models (Saylor 2021). This technology can reduce the number of live specimens used for fish passage testing and can reduce costs through reuse of the device. The captured data are used for dose response models that can facilitate improved fish-friendly turbine designs. Future research using Gelfish will investigate the use of surrogate skeletal structures and more sophisticated sensors, which can use improved hydropower testing capabilities. The questions in Table 7 are representative and may not be comprehensive; a technology developer must assemble a robust and technology-specific set of questions based on specified design objectives and application context for the technology.

**Table 7. Validation questions, test factor combinations, and rationale for the biomimetic fish sensors innovation example.** Testing factor combination abbreviations—scale: model (M) and full scale (F); water condition: dry (D), submerged (S), and flow-through (F); system completeness: component (C) and system (S); ambient time variance: steady (S) and transient (T); response: steady (S), dynamic (D), and trended (T)

Design objective category	Validation question	Testing factor combinations					Rationale
		Scale	Water condition	System completeness	Ambient time variance	Response	
H&S	What are the potential hazards associated with deployment and collection of biomimetic fish passage sensors?	M	F	S	*	*	These sensors are useful in both model- and full-scale conditions, particularly in lab settings where the device can be easily inserted and retrieved.
		F	F	S	*	*	Further testing may be useful to determine the procedures required to deploy and retrieve sensors if testing at a full-scale facility.
RRM	Is sensor functionality, accuracy, or sensitivity altered by embedment in the ballistic gel?	M	S	*	*	*	Testing in a submerged environment can help understand how the biomimetic material (e.g., a ballistic gel) affects the response of embedded sensors.
	How similar are the material properties and the printed design characteristics to those of a real fish?	F	D	C	S	S	Material and design of the full-scale sensor may be validated for accuracy in relation to the real specimen in a laboratory space in the dry. The properties of the material (i.e., a component of the sensor) and the overall printed characteristics may be subjected to steady-state, static analyses to assess resistance, flexibility, composition, and so on.
	How well does the device survive extreme events (e.g., overstress, over-capacity)?	F	S	*	*	*	Testing is needed to understand the range of forces that can be withstood during turbine passage, which can be done at full scale with blade strike simulators (turbine components) rather than full-scale turbines.
		F	F	*	*	*	The same test may require validation using a full-scale turbine with water flowing through.
ECF	How many times can the device be used for turbine passage and how does this affect the cost comparison between live specimen testing?	F	F	S	*	*	The economic value of the device comes from reducing the cost by not using live specimens, and from the ability to reuse the device if no damage is done between runs. Testing at full-scale flow-through conditions is needed to identify the durability of each device.
EI	How well does the device mimic fish behavior during passage?	F	F	S	*	*	The device is used to imitate fish during turbine passage, so testing is needed to show that the behavior is similar. This would require a comparison of the reference species and the mimetic device at full-scale flow-through conditions.

Notes: An asterisk (\*) indicates that testing under all possible alternatives for the indicated test factor is likely to be useful. For example, an asterisk listed for water condition indicates that useful testing is beneficial with dry, submerged, and flow-through conditions. The letters used for the testing factor combinations are defined in Figure 4.

The testing factor combinations columns of Table 7 indicate how each validation question invokes test factors and conditions necessary to provide results that answer the question. The final column in the table provides a preliminary rationale for the particular combination of test factors indicated. Figure 9 combines all the test factors listed for biometric fish sensors for the limited list of exemplary questions and highlights in green shading the potential testing pathways required.

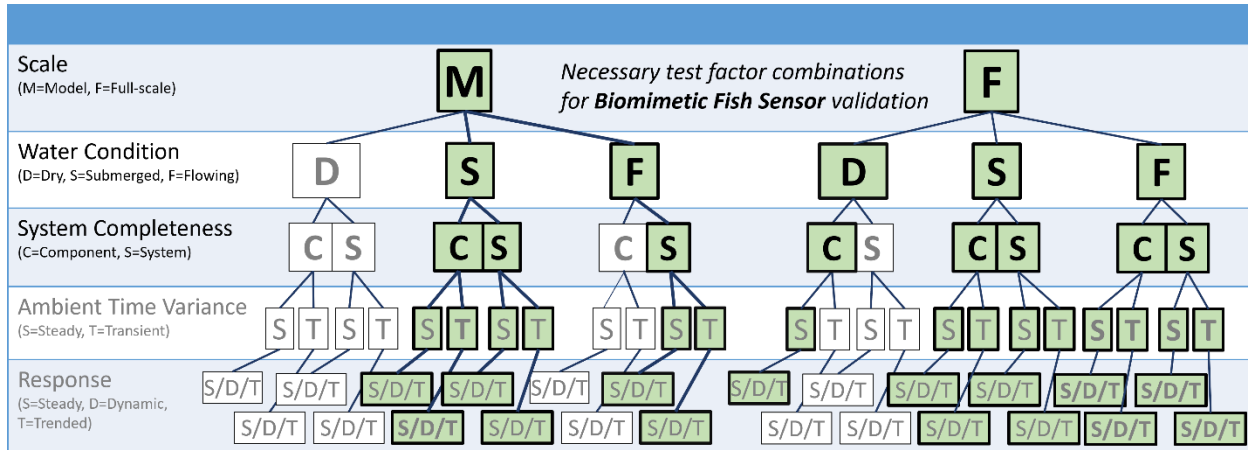

**Figure 9. The test factor pathways of the biometric fish sensor innovation example.** Green shading highlights the potential testing pathways required.

### 3.2 THEMATIC CHALLENGES FOR TESTING HYDROPOWER INNOVATIONS

The test factor pathways in Section 3.1 demonstrated that all combinations of all testing factors are likely required to validate emerging hydropower technologies at various stages of commercialization. This report aims to provide recommendations for future testing capabilities, so the testing needs that are most important to future US hydropower development in this context are prioritized. Considering the review of hydropower testing in Section 2, the example innovations in Section 3.1, and the RFI responses from industry stakeholders (Appendix C provides more details), high-level themes can be highlighted regarding the challenges that the current hydropower industry may face when testing innovations in the United States. These thematic challenges help narrow the focus from the broad review of hydropower testing to the areas of concern for modern stakeholders that should be addressed with additional investment, as described in Section 5.

***Theme 1: Full-scale testing is necessary to validate some hydropower innovations.***

The need for full-scale validation arises from three principal aspects of an innovation. The first aspect is the risk that a first adopter of an innovation assumes. In many cases, the adoption of a single hydropower innovation represents an enormous capital expenditure and significant consequences for the asset owner should the innovation fail to perform as intended. Capital expenses include design, fabrication, and installation. Installation disrupts normal operations and creates opportunity costs for power and services not produced. The potential consequences of failure include injury to workers and the public, adverse ecological effects, public and private property damage, damage to equipment or structures within a facility, and costs to decommission the innovation and restore an asset to a satisfactory working condition. Consequences and lost opportunities over the lifetime of the affected asset may also be associated with capabilities that were projected but not achieved, such as energy gains, flexible provision of power system services, and environmental enhancements or mitigations. With reference to Table 2, fish-friendly turbines, small modular turbines, aerating turbines, variable speed machines, unconventional turbine/generator configurations, environmentally acceptable lubricants, fish passage hydraulics designs,

sediment passage hydraulic designs, aerating hydraulic designs, flow measurement technologies, concrete printing, modular geotechnical foundations, and embedded sensors each present significant first-adopter risks with significant consequences of failure.

The second aspect requiring full-scale validation is the dependence of many physical and ecological phenomena on absolute scale, and the limited ability of designers to account for that dependence with certainty. For example, decades of engineering development enable turbine manufacturers to validate designs using scaled physical models based on the geometric (identical length ratios), kinematic (identical velocity ratios), and dynamic (identical force ratios) similarity. These similarity criteria, combined with well-established empirical relationships or thresholds for effects of viscosity (Reynolds number), flow stability (Froude number), and cavitation (Thoma number), enable designers to effectively predict prototype mechanical performance at full scale based on model results. However, the introduction of environmental concerns in turbine design objectives and constraints requires additional similarity criteria that are difficult or impossible to fully satisfy at model scale. Fish with realistic mechanics and behavioral responses are not available at model scale. The motion of sediment particles at model scale are affected by viscous forces that are insignificant at full scale. Air bubble breakup and coalescence and gas transfer via turbulent (in addition to molecular) diffusion from bubbles to dissolved oxygen and nitrogen in tailwaters depends on the ratio of bubble diameter to turbine diameter, which are different at model and prototype scales. With reference to Table 2, fish-friendly turbines, aerating turbines, fish passage hydraulic designs, sediment passage hydraulic designs, aerating hydraulic designs, flow measurement technologies, concrete printing, and geotechnical foundation design each present physical or ecological mechanisms that are not easily validated at model scales.

Complexity of design, operation, and maintenance is the third aspect of an innovation that may prompt potential first adopters to insist on full-scale validation as a prerequisite to adoption—particularly in situations for which complexity resides at the interface of the innovation with the balance of a hydropower facility, or the innovation depends on novel systems integration of previously unintegrated components to become a functional whole capable of meeting specifications for performance and maintainability. An example of these complexity concerns is the 1990s to present maturation of turbine aeration technology for hydropower facilities. Introduction of air into the turbine flow requires modifications to the turbine shaft, head cover, blades, hub, and discharge ring (depending on the specific aeration design), creates the potential for water to backflow into the wheel pit, and affects the capabilities of the turbine. It also creates a complex control challenge for operators seeking to maintain downstream dissolved oxygen and total dissolved gas concentrations, and introduces additional maintenance requirements related to valves and sensors for air admission. In the case of turbine aeration design, these complexities were addressed through combinations of model testing and pilot testing at full scale. However, progression of turbine aeration technology to commercialization over three decades might have been accelerated with the availability of a full-scale test facility in which multiple aeration designs could be tested and evolved. A full-scale testing capability for turbines with higher heads and flows than what existing capabilities can test could also support future R&D to further optimize aeration designs, reduce initial and operating costs of aeration designs, and support development of aeration technology targeted at small hydropower installations.

***Theme 2: Validation of environmental mitigation technology innovation requires a coordinated community effort.***

Hydropower facilities affect and function within complex and hierarchical ecosystems. River systems include multiple watersheds, which include multiple streams with multiple hydropower facilities and other infrastructure. Impoundments, including those with hydropower assets, create reservoirs and tailwaters with distinct sets of lentic and lotic characteristics. Reservoirs and tailwaters include riparian, littoral, benthic, limnetic, profundal, and benthic zones, each with distinctive habitat and assemblage of

biota. A comprehensive discussion of how infrastructure development (including hydropower) affects these hierarchical ecosystems is beyond the scope of this report. What is relevant in the context of this report is that a particular technological innovation aimed at mitigating a potentially undesirable effect of hydropower development and operation must, ultimately, address a vast array of challenges, and validating that innovation on its pathway to commercialization requires input and expertise from many scientific, technological, and policy disciplines. These challenges include gaps in ecological science (or absence of scientific consensus), insufficient monitoring of ecosystems before and after mitigation, potential trade-offs among multiple ecosystems and multiple species, diversity of stakeholder values and priorities, how ecological objectives are translated into regulatory requirements, and the value of hydropower production compared with the costs of mitigations.

More specifically, establishing design objectives and constraints for a mitigation technology innovation often requires technology developers to access expertise and knowledge about which life stages of which species in which aquatic zones are impaired or improved, and how the mechanism of mitigation is influenced by design. To understand the value of their innovation, developers of certain technologies must gain insight into the mechanism through which their mitigation technology innovation creates or enhances habitat upstream or downstream of a facility, such as in the case of aeration and sediment handling technologies. Technology developers attempting to progress from conceptualization to commercialization must incorporate these ecological concerns and design influences into testing plans and selection of test factors as they engineer and test the components and the complete prototype of an innovation. Failure to do so creates the risk of not meeting the expectations of regulators, natural resource agency experts, environmental stakeholders, and environmental subject matter experts that ultimately influence the decisions of first adopters of a mitigation technology innovation.

Few developers of environmental mitigation technology have the full suite of in-house expertise and facilities to address the aforementioned challenges. They may seek advice, testing services, analyses, and design support from several entities, and they may struggle to maintain the momentum and coherence of their development and testing. Most developers would benefit from a coordinated, systematic, and phased (stage-gated) approach to testing and validation with input and review by an established validation program with a community of experts and network of facilities (some of which already exist). Potential benefits of such an arrangement include credibility with agencies and stakeholders, use of best available science within testing activities, and efficiency and consistency of results by ensuring that testing and test results from multiple providers are coordinated and complementary. In addition, regional coordinated capabilities spread throughout the United States may facilitate environmental testing in different ecosystems, thus increasing the number of potential environmental validating conditions.

***Theme 3: Hydropower flexibility must be defined, evaluated, and validated if it is to be valued and commercialized.***

Most utility company industry participants and stakeholders have a general understanding of flexibility as a desirable characteristic of generation assets, including hydropower. Most would agree that a flexible asset exhibits one or more of the capabilities to start and stop generation multiple times per day, operate efficiently over a wide range of power output, ramp power output up or down rapidly in response to power system signals, operate efficiently for extended periods as spinning reserve, and, for pump-turbines, vary load (power input) in response to power system requests or signals. Flexibility also implies that these capabilities are made available with sufficient reliability at a cost that is equal to or less than costs of services from other flexible assets.

The principal question for technology developers and first adopters seeking flexibility is how to test and validate the capability to provide flexibility. Policy forums and interconnection-wide modeling efforts develop insights and progress toward recommendations using abstracted, idealized representations of

hydropower flexibility in modeled scenarios. Although power market design is beyond the scope of this report, the market rules, defined products and services, and price signals associated with power system reliability and resilience help to define opportunities to provide flexibility. Technology developers and first adopters, however, need more precise standards for assessments and specifications of how much their innovations improve hydropower flexibility, how long flexibility can be sustained, how often flexibility can be provided, and how design choices influence the capability and the costs of the flexibility-enhancing innovation. Technology developers may not need to test at full scale under flow-through conditions to validate flexibility innovations, but they do need access to facilities and expertise that can assess capabilities using component tests, scaled models, and simulations with ensured fidelity.

***Theme 4: Advanced materials and manufacturing for hydropower components will require updated testing and validation procedures to enable innovative designs.***

Advanced materials and manufacturing have potential application in nearly every innovation trend in Table 2, as also highlighted in more detail in Section 2. Potential strategies for incorporating advanced materials and manufacturing in hydropower technology innovation include high-performance polymer composites, such as carbon fiber, in high-strength applications; low-cost polymer composites in applications in which components are easily and often replaced; prefabricated modular structures for dams and powerhouses; and advanced fabrication methods (e.g., additive manufacturing) with metal and polymer composites (including polymer concrete) that enable complex component shapes. For example, these complex shapes could be applied to internal passages for air delivery through turbine blades or printed concrete sluiceways, which create swirling flow to better control sediment accumulation at reduced costs compared with traditional cast or machined components. Advanced materials and manufacturing could also help address the civil works challenge, which might undermine future NPD retrofit projects. However, these advanced materials and manufacturing strategies add to the complexity of hydropower technology development:

- A traditional part cannot typically be replaced one-to-one with a part using advanced materials and manufacturing. Therefore, one-to-one replacement is not the best long-term strategy for performance improvement or cost reduction within a machine. Greater improvements may be possible through redesign of multiple parts or an entire subsystem within a machine or structure. The response of the component, machine, or structure to normal and extreme conditions and loadings will be different than traditional technology, and that response must be understood through testing.
- Modular and printed structures will likely require new constructability guidelines, new construction techniques, and new inspection and commissioning procedures to realize performance increases or cost reductions from these advanced technologies. Developing these new techniques and procedures during pilot testing, rather than in a fully commercial project, may prevent costly and confidence-eroding failures of advanced technologies.
- Innovative sensors in new locations may be embedded in advanced components to enable more robust predictive and condition-based maintenance. Because the shape, strength, stiffness, and other properties of the component and its material may be different than traditional technology, testing will be needed to develop guidelines for normal and abnormal sensor readings.

## 4. EXISTING TEST FACILITIES AND CAPABILITIES FOR HYDROPOWER TESTING

This section provides an overview of testing facilities and capabilities that exist in the United States and are applicable to the validation of hydropower technology innovations. These facilities may explicitly test technologies involved in hydropower, such as those in the five physical design categories, or have functionalities that are applicable to testing current or future hydropower technologies. Section 2 outlines innovation areas for each of the physical design categories, and conventional testing procedures are summarized in Appendix A. Section 4.1 highlights where and how hydropower tests are typically performed in the United States based on an owner type categorization. Section 4.2 summarizes a similar effort recently conducted for the nascent marine energy industry, which resulted in the institution of the TEAMER (Testing Expertise and Access for Marine Energy Research) program sponsored by the DOE, through WPTO, and directed by the Pacific Ocean Energy Trust.

### 4.1 FACILITIES AND CLASSIFICATIONS

Although a full compilation of the several relevant US laboratories is outside the scope of this report, it is helpful to identify the common classes of facilities with the primary mission of testing hydropower related technologies. These facilities can be categorized by owner type into the following four categories: national laboratories, academic laboratories (i.e., universities), private facilities (i.e., companies, research centers, and laboratories), and federal facilities (e.g., USACE, USBR, and TVA). The purpose of this format is to highlight the different business models and methods of engagement, qualitatively discuss common testing issues, and identify major capabilities.

Different organizations have different objectives and priorities that influence the way they engage with potential external collaborators. Specifically, an institution may prioritize personal or partnership research and thus propose original projects, pursue funding, and manage the testing initiative. Alternatively, an institution may serve as external expert testing, conducting testing and analysis on a specific product/design on behalf of an external developer/research entity. Finally, an institution may simply allow external organizations to rent its facilities for a limited period of time and allow them to run their tests independently.

Common testing challenges are also worth discussing for external testing, especially since the four types of facilities identified might differ substantially. These challenges mostly revolve around funding, the outcomes dissemination, and contracting.

- *Funding*—who pays for the testing and what the source of the funding is, whether private or public
- *Intellectual property (IP)*—how the IP is handled; an existing IP might need to be protected (e.g., a new turbine design that the developer wants to be tested in an accredited private institution), or a new joint IP might need to be dispositioned (i.e., development of a new IP in tandem between the developer and the tester/research institution)
- *Dissemination of research*—whether the outcomes are going to be publicly available and is so, how they will be published
- *Standards, quality, compatibility, acceptability* of the tests and results
- *Workforce education* of the next generation of technicians (e.g., students that work in academic labs or engineers and technicians that work in private labs)



- *Ease of contracting*—how long the planning and contracting phase is, how many parties are involved, and what the potential bureaucratic steps are
- *Ease of access*—how accessible the facility is with respect to physical access and level of security
- *Scheduling and availability*—the duration and availability of testing, particularly when multiple interested parties may create long lead/wait times

Finally, an overview is provided of the strengths and capabilities within the five physical design categories for each of the four facility types. The combination of all the information collected ultimately aims at identifying potential collaboration avenues for future testing infrastructure.

The information was collected in several ways. Information about national laboratories and federal facilities was found using a DOE RFI, the TEAMER website,<sup>48</sup> and organizational websites. Information about university and private company capabilities was found using web searches. The capabilities are identified by the overarching name of the facility or research center, which have specific personnel, equipment, missions, and funding. However, an organization may have one or more applicable facility. For example, ORNL oversees four research centers that could be used for hydropower testing. However, for facilities with multiple testing structures such as a wave basin and a towing tank, the research center was only recorded once. Each facility was qualitatively catalogued using the hydropower technology landscape and dimensions of testing approaches described previously. These lists are not comprehensive and will continue to be amended in the future through ongoing stakeholder engagement and collaborations.

#### 4.1.1 National Laboratories

In total, 17 US national laboratories support a variety of government-sponsored projects. Several have hydropower-specific research groups, and most, if not all, have relevant research infrastructure. National laboratories conduct a mix of basic and applied research and provide interdisciplinary teams of experts, state-of-the-art equipment, and funding mechanisms that are beneficial for early-stage innovations. Projects are often funded through grants and government funding, and outcomes often include scientific articles/reports, patents, and commercialization-ready technology. National labs can also represent third-party institutions since these labs are typically not affiliated with particular company stakeholders. Interaction with industry stakeholders is possible and is regulated in various ways. User facilities allow companies to enter into proprietary or nonproprietary user agreements that enable them to develop and evaluate technologies using the specialized facilities, equipment, and dedicated staff of national labs. Cooperative research and development agreements (CRADAs), strategic partnership project agreements (SPP), technical service agreements, and agreements for commercializing technology (ACT) are also ways that industry can partner with national labs and governmental agencies on projects despite the differences in funding sources, lab responsibilities, and IP rights.<sup>49</sup> National labs are also known for supporting funding opportunity announcements (FOAs) or prizes that can provide funding and technical support to winning applicants.

In total, 5 of the 17 national labs have specific testing capabilities relevant to hydropower technology that will be fundamental to support future innovations: Idaho National Laboratory (INL), National Renewable Energy Laboratory (NREL), ORNL, PNNL, and Sandia National Laboratories (SNL). Their capabilities are summarized at a high level in Table 8 and span all five physical design categories of the hydropower technology landscape, highlighting the wide breadth of opportunities at US national laboratories. The full list of facilities and instrumentation with detailed information is not reported in Table 8 for the sake of

---

<sup>48</sup> <https://teamer-us.org/>

<sup>49</sup> <https://www.nrel.gov/workingwithus/technology-partnership-agreements.html>

brevity, but each specific facility's website provides more details. The full list of detailed capabilities was cataloged during the preparation of this report and is intended to be amended and made publicly available as new testing opportunities and investments arise.

Within the powertrain category, testing capabilities are targeted toward conventional and innovative technologies. Several facilities host a series of dynamometers and engine and power take-off test stands, commonly used for simulating generators, validating digital real-time simulators, and testing supporting electromechanical equipment. Most of the capabilities for powertrain testing operate in the dry and could handle model- and full-scale prototypes. Some facilities also have hydraulic capabilities that could be associated to turbine testing at small scales. Several labs house test stands and instrumentation to perform powertrain environmental testing (Turbine environmental testing in Section 2.1.1.1). These tests include fish strike tests (using both live fish and surrogates), testing of underwater instrumentation in support of fish passage and water quality monitoring (e.g., environmentally friendly lubricants and aeration), water security, scale testing of small hydropower turbines, and corrosion testing of composite runners. National labs are well versed in advanced materials and manufacturing, and in structural testing in general. These specific sets of capabilities can be applied transversally to most of the five physical design categories, such as powertrain, conveyance, structures, and electrical interconnection. Almost all the national labs are pioneering advanced manufacturing techniques and material testing at a global scale. The national laboratories also excel in the areas of electrical interconnections and controls research. Several labs have energy systems integration laboratories that excel at physically and digitally representing the grid to study how energy resources such as hydropower interact with other resources and control systems. In this regard, a few facilities have also high-performance supercomputing capabilities that can be used to optimize designs and physical testing.

**Table 8. Examples of existing hydropower testing capabilities at US national laboratories spanning the five physical design categories of the hydropower technological landscape**

	<b>Powertrain</b>	<b>Conveyance</b>	<b>Structures</b>	<b>Electrical interconnection</b>	<b>I&amp;C</b>
<b>INL</b>	Water security test bed <a href="https://www.youtube.com/watch?v=pQvsBC-U4a8">https://www.youtube.com/watch?v=pQvsBC-U4a8</a>	Water security test bed <a href="https://www.youtube.com/watch?v=pQvsBC-U4a8">https://www.youtube.com/watch?v=pQvsBC-U4a8</a>			Water security test bed <a href="https://www.youtube.com/watch?v=pQvsBC-U4a8">https://www.youtube.com/watch?v=pQvsBC-U4a8</a>
	Systems Integration Laboratory				
<b>NREL</b>	225 kW, 2.5 MW, and 5 MW dynamometers <a href="https://www.nrel.gov/wind/facilities-dynamometer.html">https://www.nrel.gov/wind/facilities-dynamometer.html</a>	Structural validation laboratories <a href="https://www.nrel.gov/water/facilities-structural.html">https://www.nrel.gov/water/facilities-structural.html</a>	Structural validation laboratories <a href="https://www.nrel.gov/water/facilities-structural.html">https://www.nrel.gov/water/facilities-structural.html</a>	Advanced Research on Integrated Energy Systems (ARIES): Digital Real-Time Simulation (DRTS) Clusters <a href="https://www.nrel.gov/aries/">https://www.nrel.gov/aries/</a>	ARIES: Digital Real-Time Simulation (DRTS) <a href="https://www.nrel.gov/aries/">https://www.nrel.gov/aries/</a>
	Water power systems laboratories <a href="https://www.nrel.gov/water/system-component-testing-validation.html">https://www.nrel.gov/water/system-component-testing-validation.html</a>	Material characterization capabilities (100, 250, and 500 kN load frame) <a href="https://www.nrel.gov/water/facilities-structural.html">https://www.nrel.gov/water/facilities-structural.html</a>	Material characterization capabilities (100, 250, and 500 kN load frame) <a href="https://www.nrel.gov/water/facilities-structural.html">https://www.nrel.gov/water/facilities-structural.html</a>	Variable speed 2.5 MW hydro-generator <a href="https://www.nrel.gov/aries/">https://www.nrel.gov/aries/</a>	ARIES: At-scale Real-time Hydro Emulation <a href="https://www.nrel.gov/aries/">https://www.nrel.gov/aries/</a>
	Distributed, Integrated Energy Laboratory (DIEL) <a href="https://www.nrel.gov/aries/">https://www.nrel.gov/aries/</a>	Composites Manufacturing Education and Technology Facility (CoMET) <a href="https://www.nrel.gov/wind/facilities-comet.html">https://www.nrel.gov/wind/facilities-comet.html</a>	Composites Manufacturing Education and Technology Facility (CoMET) <a href="https://www.nrel.gov/wind/facilities-comet.html">https://www.nrel.gov/wind/facilities-comet.html</a>	MW-level variable renewable and energy storage hardware assets <a href="https://www.nrel.gov/about/assets/pdfs/flatirons-site-map.pdf">https://www.nrel.gov/about/assets/pdfs/flatirons-site-map.pdf</a>	Low-power power electronics building block (PEBB) test bed <a href="https://www.nrel.gov/aries/">https://www.nrel.gov/aries/</a>
	Advanced Research on Integrated Energy Systems (ARIES) <a href="https://www.nrel.gov/aries/">https://www.nrel.gov/aries/</a>			Low-power power electronics building block test bed <a href="https://www.nrel.gov/aries/">https://www.nrel.gov/aries/</a>	Variable speed 2.5 MW hydro-generator <a href="https://www.nrel.gov/aries/">https://www.nrel.gov/aries/</a>

**Table 8. Examples of existing hydropower testing capabilities at US national laboratories spanning the five physical design categories of the hydropower technological landscape (continued).**

	<b>Powertrain</b>	<b>Conveyance</b>	<b>Structures</b>	<b>Electrical interconnection</b>	<b>I&amp;C</b>
	Variable speed 2.5 MW hydropower generator <a href="https://www.nrel.gov/aries/">https://www.nrel.gov/aries/</a>			Advanced distribution management system test bed <a href="https://www.nrel.gov/esif/integrated-energy.html">https://www.nrel.gov/esif/integrated-energy.html</a>	MW-level variable renewable and energy storage hardware assets <a href="https://www.nrel.gov/aries/">https://www.nrel.gov/aries/</a>
				Cyber range <a href="https://www.nrel.gov/security-resilience/cyber-energy-emulation-platform.html">https://www.nrel.gov/security-resilience/cyber-energy-emulation-platform.html</a>	Cyber range <a href="https://www.nrel.gov/security-resilience/cyber-energy-emulation-platform.html">https://www.nrel.gov/security-resilience/cyber-energy-emulation-platform.html</a>
				Energy Systems Integration Facility: power electronics <a href="https://www.nrel.gov/esif/energy-sciences.html">https://www.nrel.gov/esif/energy-sciences.html</a>	Distributed, Integrated Energy Laboratory (DIEL) <a href="https://www.nrel.gov/aries/">https://www.nrel.gov/aries/</a>
				Dynamic power hardware-in-the-loop (P-HIL)	ESIF: power electronics <a href="https://www.nrel.gov/esif/energy-sciences.html">https://www.nrel.gov/esif/energy-sciences.html</a>
				Controller hardware-in-the-loop (C-HIL)	Microgrid control <a href="https://www.nrel.gov/grid/microgrid-controls.html">https://www.nrel.gov/grid/microgrid-controls.html</a>
<b>ORNL</b>	Power electronics and electric machinery <a href="https://www.ornl.gov/content/power-electronics-and-electric-machinery-peem-research-center">https://www.ornl.gov/content/power-electronics-and-electric-machinery-peem-research-center</a>	Aquatic Ecology Laboratory <a href="https://www.ornl.gov/content/aquatic-ecology-laboratory">https://www.ornl.gov/content/aquatic-ecology-laboratory</a>	Manufacturing Demonstration Facility <a href="https://www.ornl.gov/facility/mdf">https://www.ornl.gov/facility/mdf</a>	Battery Manufacturing R&D Facility <a href="https://www.ornl.gov/content/battery-manufacturing-facility">https://www.ornl.gov/content/battery-manufacturing-facility</a>	Aquatic Ecology Laboratory <a href="https://www.ornl.gov/content/aquatic-ecology-laboratory">https://www.ornl.gov/content/aquatic-ecology-laboratory</a>
	Vehicle systems integration <a href="https://www.ornl.gov/facility/ntrc/research-areas/vehicle-systems">https://www.ornl.gov/facility/ntrc/research-areas/vehicle-systems</a>	Manufacturing Demonstration Facility <a href="https://www.ornl.gov/facility/mdf">https://www.ornl.gov/facility/mdf</a>		Grid Research Integration and Deployment Center <a href="https://www.ornl.gov/gridc">https://www.ornl.gov/gridc</a>	Grid Research Integration and Deployment Center <a href="https://www.ornl.gov/gridc">https://www.ornl.gov/gridc</a>
	Aquatic Ecology Laboratory <a href="https://www.ornl.gov/content/aquatic-ecology-laboratory">https://www.ornl.gov/content/aquatic-ecology-laboratory</a>				Oak Ridge Leadership Computing Facility <a href="https://www.olcf.ornl.gov/">https://www.olcf.ornl.gov/</a>

**Table 8. Examples of existing hydropower testing capabilities at US national laboratories spanning the five physical design categories of the hydropower technological landscape (continued).**

	<b>Powertrain</b>	<b>Conveyance</b>	<b>Structures</b>	<b>Electrical interconnection</b>	<b>I&amp;C</b>
	Manufacturing Demonstration Facility <a href="https://www.ornl.gov/facility/mdf">https://www.ornl.gov/facility/mdf</a>				
<b>PNNL</b>	Kaplan turbine trunnion bushing test stand	Fluid shear stress facility	Fluid shear stress facility	Electricity Infrastructure Operations Center <a href="https://www.pnnl.gov/projects/eioc">https://www.pnnl.gov/projects/eioc</a>	Systems Engineering Building
	Corrosion fatigue test machine (in development)	Large-scale test tank	Large-scale test tank	Grid Storage Launchpad	Bio-Acoustics and Flow Laboratory <a href="https://www.pnnl.gov/bio-acoustics-and-flow-laboratory">https://www.pnnl.gov/bio-acoustics-and-flow-laboratory</a>
	Scale turbine test facility for small hydropower	Aquatic Research Laboratory <a href="https://www.pnnl.gov/aquatic-research-laboratory">https://www.pnnl.gov/aquatic-research-laboratory</a>	Energy Sciences Center	Advanced Battery Facility	CyberNET Testbed
	Applied Processing Engineering Laboratory	Mobile Aquatic Barotrauma Laboratory			Chinook supercomputer
		Bioacoustic and Flow Laboratory <a href="https://www.pnnl.gov/bio-acoustics-and-flow-laboratory">https://www.pnnl.gov/bio-acoustics-and-flow-laboratory</a>			
<b>SNL</b>	Sandia Wave Power Take-Off Laboratory (dyno testing) <a href="https://energy.sandia.gov/keycapabilities/facilities/swep-t-lab/">https://energy.sandia.gov/keycapabilities/facilities/swep-t-lab/</a>	Advanced Materials Laboratory	Advanced Materials Laboratory	Battery Abuse Laboratory <a href="https://www.youtube.com/watch?app=desktop&amp;v=9n6uljkLJKo&amp;list=PLouetuxaIMDpNFQqLYAbefNff1NPYQaVx&amp;index=4">https://www.youtube.com/watch?app=desktop&amp;v=9n6uljkLJKo&amp;list=PLouetuxaIMDpNFQqLYAbefNff1NPYQaVx&amp;index=4</a>	Sandia Wave Power Take-Off Laboratory (dyno testing) <a href="https://energy.sandia.gov/keycapabilities/facilities/swep-t-lab/">https://energy.sandia.gov/keycapabilities/facilities/swep-t-lab/</a>

**Table 8. Examples of existing hydropower testing capabilities at US national laboratories spanning the five physical design categories of the hydropower technological landscape (continued).**

	<b>Powertrain</b>	<b>Conveyance</b>	<b>Structures</b>	<b>Electrical interconnection</b>	<b>I&amp;C</b>
	Advanced Materials Laboratory	Tribology Lab	Tribology Lab	Advanced Power Electronic Conversion Systems Laboratory <a href="https://www.youtube.com/watch?app=desktop&amp;v=Qz9bYTeqYJE&amp;list=PLouetuxaIMDpNFQqIYAbeFNffINPYQaVx&amp;index=3">https://www.youtube.com/watch?app=desktop&amp;v=Qz9bYTeqYJE&amp;list=PLouetuxaIMDpNFQqIYAbeFNffINPYQaVx&amp;index=3</a>	CONET
	Tribology Lab	High Consequence, Automation, & Robotics Facility	High Consequence, Automation, & Robotics Facility	Distributed Energy Technologies Laboratory <a href="https://www.youtube.com/watch?app=desktop&amp;v=ElraIInTeaw">https://www.youtube.com/watch?app=desktop&amp;v=ElraIInTeaw</a>	Microsystems Engineering, Science and Applications
	High Consequence, Automation, & Robotics Facility	Mechanical Shock Complex	Mechanical Shock Complex	CONET <a href="https://www.youtube.com/watch?app=desktop&amp;v=ElraIInTeaw">https://www.youtube.com/watch?app=desktop&amp;v=ElraIInTeaw</a>	
	Mechanical Shock Complex	Microsystems Engineering, Science and Applications	Microsystems Engineering, Science and Applications	Energy Storage Test Pad <a href="https://www.youtube.com/watch?app=desktop&amp;v=G2m5oDr-DSE&amp;list=PLouetuxaIMDpNFQqIYAbeFNffINPYQaVx&amp;index=5">https://www.youtube.com/watch?app=desktop&amp;v=G2m5oDr-DSE&amp;list=PLouetuxaIMDpNFQqIYAbeFNffINPYQaVx&amp;index=5</a>	
	Microsystems Engineering, Science and Applications			Energy Storage Controls and Analysis Laboratory <a href="https://www.youtube.com/watch?app=desktop&amp;v=G2m5oDr-DSE&amp;list=PLouetuxaIMDpNFQqIYAbeFNffINPYQaVx&amp;index=5">https://www.youtube.com/watch?app=desktop&amp;v=G2m5oDr-DSE&amp;list=PLouetuxaIMDpNFQqIYAbeFNffINPYQaVx&amp;index=5</a>	
				Battery Energy Storage Test Laboratory (BEST)	

**Table 8. Examples of existing hydropower testing capabilities at US national laboratories spanning the five physical design categories of the hydropower technological landscape (continued).**

	Powertrain	Conveyance	Structures	Electrical interconnection	I&C
				Battery Test Facility <a href="https://www.youtube.com/watch?app=desktop&amp;v=9n6uljkLJKo&amp;list=PLouetuxaIMDpNFQqIYAbeFNff1NPYQaVx&amp;index=4">https://www.youtube.com/watch?app=desktop&amp;v=9n6uljkLJKo&amp;list=PLouetuxaIMDpNFQqIYAbeFNff1NPYQaVx&amp;index=4</a>	
ANL	Distributed Energy Research Center <a href="https://www.anl.gov/taps/distributed-energy-research-center">https://www.anl.gov/taps/distributed-energy-research-center</a>	High Temperature Corrosion Test Facility <a href="https://www.anl.gov/amd/high-temperature-corrosion-test-facilities-and-high-pressure-test-facilities-for-metal-dusting">https://www.anl.gov/amd/high-temperature-corrosion-test-facilities-and-high-pressure-test-facilities-for-metal-dusting</a>	High Temperature Corrosion Test Facility <a href="https://www.anl.gov/amd/high-temperature-corrosion-test-facilities-and-high-pressure-test-facilities-for-metal-dusting">https://www.anl.gov/amd/high-temperature-corrosion-test-facilities-and-high-pressure-test-facilities-for-metal-dusting</a>	Power Electronics and Controller Prototyping Lab	Robotics and Augmented Reality Laboratory <a href="https://www.anl.gov/amd/robotics-and-augmentedreality-laboratory">https://www.anl.gov/amd/robotics-and-augmentedreality-laboratory</a>
	Tribology Laboratory <a href="https://www.anl.gov/amd/tribology-laboratory">https://www.anl.gov/amd/tribology-laboratory</a>	Tribology Laboratory <a href="https://www.anl.gov/amd/tribology-laboratory">https://www.anl.gov/amd/tribology-laboratory</a>	Tribology Laboratory <a href="https://www.anl.gov/amd/tribology-laboratory">https://www.anl.gov/amd/tribology-laboratory</a>		Secure Cyber Testbed <a href="https://www.anl.gov/sss/secure-cyber-testbed">https://www.anl.gov/sss/secure-cyber-testbed</a>
	Metal Additive Manufacturing Laboratory <a href="https://www.anl.gov/nse/metal-additive-manufacturing-laboratory">https://www.anl.gov/nse/metal-additive-manufacturing-laboratory</a>		Mechanical and Environmental Testing Lab <a href="https://www.anl.gov/nse/mechanical-and-environmental-testing-laboratory-metlab">https://www.anl.gov/nse/mechanical-and-environmental-testing-laboratory-metlab</a>		
			Materials Engineering Research Facility <a href="https://www.anl.gov/aet/materials-engineering-research-facility">https://www.anl.gov/aet/materials-engineering-research-facility</a>		

#### 4.1.2 Academic Laboratories

Most national and international universities have research facilities within their departments that support the educational mission of the institution and, more significantly, foster academic R&D. Academic laboratories are often run by a specific department and/or by a professor/principal investigator who is responsible for obtaining external funding through sponsored research proposals. Some facilities are multidisciplinary and are managed by various programs (e.g., the Saint Anthony Falls Laboratory at the University of Minnesota<sup>50</sup>). Academic research can span across fundamental and applied science, and this research is typically conducted by students and technicians. The main outcomes are peer-reviewed publications, outreach, patents, and IP that are controlled and owned by the university. Universities are driven by scientific production, significantly more so than any other institution. Other than their independent research, universities also work in partnership with other academic centers, the private sector and, less commonly, federal agencies. Universities typically lead these partnerships through their professors and research associates by submitting the initial proposal, obtaining funding, and managing the research activities. Academic laboratories are also hired as external subcontractors; professors and personnel are consulted as external experts, and/or facilities are requested for specific tests by outside companies that own and manage the project. Academic facilities are typically fairly accessible considering their primary educational scope and history. Universities have dedicated legal departments that can easily manage external contracting, new IP, protect existing IP, and are experienced in handling outside contracts. Workforce education is paramount for universities and their primary missions. Students are not only the primary beneficiary of the educational services but are also essential contributors to research and innovation.

Hydropower research is typically conducted at engineering and physical sciences universities and, because of its multidisciplinary nature, can be catalogued under several departments. Historically, hydropower has always been categorized as a civil engineering topic, mostly because hydraulic and structural problems are at the base of its design. As highlighted in Appendix A.2, physical scaled models of entire facilities were created in laboratory environments to assess and resolve potential problems with their designs. Universities hosted a large number of these tests throughout the years. Hydraulic and structural laboratories are the most common applied research facilities of civil engineering departments. Hydraulic laboratories are typically characterized by open channels, towing tanks, and basins of different scales, and can be used to investigate the performance, safety, and resilience of conveyance structures. However, considering the size of hydropower structures and laboratory spaces, hydraulic studies are typically performed at partial scales (i.e., with scaled models) according to nondimensional scaling rules (Appendix A.2). At least 21 US universities have substantial hydraulic testing capabilities. Most of the hydraulic facilities are flumes (i.e., open channels), basins, and towing tanks of different sizes, flow capacities, slope variabilities, and other simulation capabilities (e.g., wave generation, sediment transport, biota interaction). For example, the Offshore Technology Research Center of Texas A&M University has one of the biggest basins at 150 ft (45.7 m) long, 100 ft (30.5 m) wide, and 19 ft (5.8 m) deep.<sup>51</sup> Oregon State University has one of the longest wave flumes at the O.H. Hinsdale Wave Research Laboratory,<sup>52</sup> which is 342 ft (104 m) long, mostly used for studies on coastal and nearshore processes, and the Marine Hydrodynamics Laboratory of the University of Michigan has the longest towing tank at 360 ft (109.7 m) long, 22 ft (6.7 m) wide, 10 ft (3 m) deep.<sup>53</sup> The University of Iowa and the Stevens Institute of Technology have long towing tank facilities (328 and 313 ft, or 100 and 95.4, respectively) used for naval research and high-speed towing tests. The Saint Anthony Fall Laboratory of the University of Minnesota

---

<sup>50</sup> <https://cse.umn.edu/saf1>

<sup>51</sup> <http://otrc.wpengine.com/otrc-wave-basin/otrc-basin-specifications/>

<sup>52</sup> <https://engineering.oregonstate.edu/facilities/wave-lab>

<sup>53</sup> <https://mhl.engin.umich.edu/facilities/basin/>



houses one of the largest open channel facilities in the country, the Main Channel.<sup>54</sup> The channel is 275 ft (83.8 m) long, 9 ft (2.75 m) wide, and 6 ft (1.8 m) deep, and it can reach a maximum flow rate of 300 cfs (8.5 m<sup>3</sup>/s) directly fed by the adjacent Mississippi river. Scaled physical models of entire facilities are typically built on empty model floors that have large space availability and hydraulic capabilities (typically pumps). For example, the IIHR–Hydrosience and Engineering laboratory at the University of Iowa has a long history of fundamental and applied hydraulic research. The campus includes 10 warehouse facilities<sup>55</sup> built to host large physical models with varying hydraulic capabilities and modern testing equipment to simulate and study almost any kind of hydraulic structure. These spaces support internal research conducted at the university and offer external consultancy services that include major hydroelectric public utility companies. Similarly, the Saint Anthony Fall Laboratory of the University of Minnesota also offers several spaces where physical models are continuously built, studied, and removed.<sup>56</sup> The physical modeling facilities at IIHR-Hydrosience and Engineering of Iowa and Saint Anthony Fall Laboratory in Minnesota are characterized by large spaces, large pumps (300 Hp for IIHR and up to 20 cfs (0.6 m<sup>3</sup>/s) for Saint Anthony Fall Laboratory), and highly sophisticated data acquisition systems (e.g., velocimeters, pressure gauges, acoustic and laser scanning devices), and they are constantly supported by machine/electrical shops and highly trained engineering personnel.

These results suggest that most of the academic hydraulic facilities are suited for earth sciences (e.g., rivers, coasts, deltas) and marine and hydrokinetic research (Section 4.2) or scaled models of hydropower technologies. However, as suggested in Section 2, there are cases in which a novel turbine or a specific hydraulic design (for water, sediments, or biota) would benefit from testing at full scale, which requires larger facilities that can host larger water drops and flow rates (conditions not currently provided by existing academic labs, or any other labs).

Structural testing is usually performed in very large spaces on specific large-scale components and systems of the superstructure. Tests include applying static and dynamic loads to measure stress resistance and failure, and assessing material properties. Geotechnical testing is sometimes associated with structural labs, as well, and they might share spaces and instrumentation. In contrast to hydraulic tests, geotechnical tests cannot typically be scaled down and are mostly performed on a component or specimen. In this case, the scale of the laboratory is less relevant for future structural innovation. However, novel materials and advanced manufacturing techniques applied to hydropower structures might require innovative testing techniques and instrumentation that academic labs might not have.

Research related to powertrains, electrical interconnection, and controls commonly occurs in mechanical and electrical engineering departments. Hydropower machines and controls are very well-established technologies and are subjects of classes and educational exercises. Modern innovation in the field of waterpower is largely focuses on new renewable technologies (which require new generation systems and control strategies), storage, cybersecurity, and grid improvement. However, considering the future evolution of energy production and markets, and the need for integrations and flexibility among all the other types of renewables, additional innovations in hydropower mechanical and electric technologies will be critical. Examples of existing capabilities at academic laboratories are the Ocean Power Generation Simulator at the Southern National Marine Renewable Energy Center of the Florida Atlantic University,<sup>57</sup> the Applied Physics Laboratory at the University of Washington,<sup>58</sup> the Power Systems Integration Lab of the University of Alaska Fairbanks,<sup>59</sup> and the Power Electronics, Microgrids & Subsea

---

<sup>54</sup> <https://cse.umn.edu/safl/main-channel>

<sup>55</sup> <https://www.iuhr.uiowa.edu/laboratories-large-scale-models/>

<sup>56</sup> <https://cse.umn.edu/safl/model-floor>

<sup>57</sup> <https://snmrec.fau.edu/technology-testing/dynamometer.html>

<sup>58</sup> <https://www.apl.washington.edu/departments/oe/home.php>

<sup>59</sup> <https://acep.uaf.edu/facilities/psi.aspx>

Electrical Systems Center of the University of Houston.<sup>60</sup> Most of these academic labs offer testing facilities using dynamometers, prototype generators, power takeoff controllers, machine health monitors, grid integration simulators, and energy storage analyses.

### 4.1.3 Private Research Centers and Laboratories

Private research centers typically offer their services as external consultants for engineering design and expert testing assistance. They may also less commonly lease their facilities and equipment to outside researchers. Typical contractors are developers, engineering firms, government agencies, and municipalities that need assistance with physical modeling or seek validation and certification for their technology. Private labs are hired as subcontractors, and the engagement is mostly unilateral and business-oriented (i.e., funding is mostly private), so the contract development is streamlined and simplified. As subcontractors, private labs are accustomed to nondisclosure agreements, obligations for the hiring company (e.g., protection of existing IP or co-development of one), and common expectations (e.g., timeline and reliability of results). Most private institutions are certified testing facilities, so they guarantee testing standards and ensure quality, compatibility, and acceptability of their results. Because testing is the primary objective and external contractors are their primary sources of business, these facilities are easily accessible in terms of security and physical access. Dissemination of results is not typically a high priority for private labs and may be regulated by the type of contract stipulated. Workforce education is also not critical for these institutions, but they likely support the constant updating of testing and design standards.

Alden Research Laboratory<sup>61</sup> is one of the largest and most well-known private research institutes for hydraulic testing and complex flows-related engineering. Alden has 150,000 ft<sup>2</sup> (13,935.5 m<sup>2</sup>) of indoor lab space on a 32 acre campus in Holden, Massachusetts, and 10,000 ft<sup>2</sup> (929 m<sup>2</sup>) of laboratory space in Everett, Washington, all dedicated to the development of physical model studies. Most of Alden's work focuses on hydraulic-scale physical modeling and testing (e.g., hydropower facilities, dam safety, flood and drainage system, rivers and waterways), turbine testing, EI studies, component testing, and hydraulic meters calibration. Permanent facilities for applied research include two large test flumes (one is 6 ft wide, 7 ft deep, and 100 ft long with flow capacity of 120 cfs (or 1.8 m wide, 2.1 m deep, and 30 m long with 3.4 m<sup>3</sup>/s), and the other is 20 ft wide, 10 ft deep, and 100 ft long with a flow capacity of 500 cfs (or 6 m wide, 3 m deep, and 30 m long with 14.2 m<sup>3</sup>/s); several large test tanks, a towing tank, and deep wave basin. Instrumentations include a state-of-the-art fish holding facility for biological evaluations; an Acoustic Doppler Current Profiler; velocity meters; transfer pumps allowing fast de-watering for modifications; a 100 t chiller; an advanced water filtration system; and a 10 t hoist. Physical testing is also supported by state-of-the-art numerical simulation expertise and capabilities, including several commercial computational fluid dynamics software. In terms of hydropower applications, Alden facilities cover a wide range of design objectives for several physical design features, including full-scale turbine performance testing, EI (e.g., fish strikes, gas exchange) studies, and conveyance performance (e.g., water, sediments, biota) studies. Specifically, the Taft Fisheries Research and Test Facility is a versatile testing facility equipped with a large recirculating flume that can support a wide range of needs, including biological and hydraulic performance evaluations. This flume has been used to evaluate biological and operational performance of numerous hydrokinetic turbines, fish guidance technologies, and fish bypass systems. Alden has a long history and experience in hydraulic turbine design and testing, partially described in Turbine environmental testing in Section 2.1.1.1 (and references therein).

---

<sup>60</sup> <https://pemses.ece.uh.edu/facilities/>

<sup>61</sup> <https://www.aldenlab.com/>

Other examples of private testing centers are ETA International in Bulverde, Texas,<sup>62</sup> Southwest Research Institute in San Antonio, Texas,<sup>63</sup> and Stress Engineering in Houston, Texas,<sup>64</sup> and they all primarily focus on mechanical and material testing. In particular, ETA International owns several dynamic and tension rigs, soak tanks, and pressure vessels, and specializes in component and power testing, and composite and non-composite structural testing. Southwest Research Institute is a multidisciplinary testing facility with design and consultant capabilities; its facilities include dynamometers, controls system support, generator testing, power take-off testing, performance testing, composite material testing, high-performance comping, and turbine testing. Stress Engineering is also a multidisciplinary testing facility mostly specialized in standardized and custom structural testing, including force, load, tension, pressure, fatigue, temperature, high pressure/high temperature, noise, vibration, torque, strain, creep, and displacement.

#### 4.1.4 Federal Testing Facilities

The differences between generic federal facilities and federal facilities with the primary scope of testing are important to distinguish for the purpose of this section. The former includes federal water infrastructure, such as existing dams and canals, which may be potential candidates to become future hydropower testing facilities, as discussed in Section 6. The latter specifically refers to laboratories and test facilities owned by federal agencies such as USBR, the US Geological Survey, and USACE. Many other agencies own and run research labs that may also be associated with hydropower research, such as the National Oceanic and Atmospheric Administration, the US Fish and Wildlife Service, and the US Department of Agriculture; this report focuses on USBR, the US Geological Survey, and USACE. These federal agencies have specific testing facilities that have historically supported the development of hydropower in the United States and continue to offer paramount assistance and regulation for operations, maintenance, and new development. Their resources (e.g., facilities, equipment, personnel) are highly qualified for expert testing of hydropower structures and technologies. Their services primarily support of their own infrastructure, but some of them have external collaborations with private industry with specific business models. These agencies typically lead their own research projects but also offer funding opportunities for joint collaborations. A typical route is through a memorandum of understanding, which is a legal agreement (not legally binding) between two parties for a common cause.

The capabilities of these agencies mostly relate to civil engineering and thus predominantly focus on conveyances' hydraulic and environmental performance testing, and structural assessment of superstructures and foundations.

The US Geological Survey owns and manage the Hydrologic Instrumentation Facility,<sup>65</sup> which supports water resources research, monitoring, and testing. The facility specializes in equipment and instrumentation for hydraulic and hydrological measurements. It has extensive technical expertise and several labs and field sites, including the following:

- *A hydraulic lab* with a towing tank, submerged jet tank, small and large acoustic tanks, constant head tank, and a tilting bed flume; these facilities are used for hydraulic flow-measuring device calibration (standards are also developed that affect US Geological Survey operations nationwide) and water resources investigations such as river modeling and transport mechanics (e.g., heat, solutes, solids)

---

<sup>62</sup> <https://etainc.org/>

<sup>63</sup> <https://www.swri.org/>

<sup>64</sup> <https://www.stress.com/>

<sup>65</sup> <https://www.usgs.gov/labs/hydrologic-instrumentation-facility>

- *Environmental chambers* to test the instrumentation in extreme temperatures conditions experienced at field deployments
- *A water quality laboratory* to test and validate water quality monitoring technologies

Overall, Hydrologic Instrumentation Facility capabilities are mostly appropriate for testing the hydraulic performance, reliability, and EI of conveyances and sensors. Sensors and monitoring strategies in particular are sometimes overlooked in hydropower testing planning, but they play a significant role in the advancement of future technologies and developments.

USACE manages the Engineer Research and Development Center (ERDC),<sup>66</sup> which addresses several research areas, including military engineering, geospatial sciences, civil works water resources, and environmental quality and installations. To support its research objectives, ERDC has several facilities and capabilities, including physical modeling, technology testing and validation, and numerical modeling. Among this list of premier labs, three groups of facilities are mostly applicable to hydropower technology testing:

- *The Coastal and Hydraulics Laboratory (CHL)*, which includes two Wave Flume Facilities, the ERDC Ship/Tow Simulator, the Field Research Facility, the Full-Scale Levee Breach and Hydraulic Test Facility, the Littoral Zone Remote Sensing Group, and the SEDflume (high-shear stress flume)
- *The Environmental Laboratory*, which includes several groups and labs for aquatic ecosystems, environmental chemistry and toxicology, sediment research, and so on
- The Materials Testing Center within the *Geotechnical and Structures Laboratory*, which provides quality material testing at reasonable costs in geotechnical and structural engineering

ERDC capabilities are suitable for hydropower testing needs spanning structural and hydraulic performance, reliability, and safety of conveyances and civil structures. In particular, the ERDC's CHL excels for its physical modeling capabilities. Scaled physical model studies addresses hydropower structure and components, including spillways, powerhouses, lock systems and operations, fish bypasses, sediment transport processes, and pumps and turbines. CHL also continues to push for advancements in modeling construction and measurement techniques; for instance, the new Waterways Lightweight Modeling System (WeLMoS) was recently developed to shape bathymetric physical models using high-density foam modeled using computer numerical control (CNC) to gain details that were seemingly impossible to achieve using concrete. The blocks are then sprayed with multiple layers of a hard coat polyurethane to seal and waterproof the surface. WeLMoS reduced construction time for the bathymetry portion of the models by 30% while increasing accuracy by 30%. CHL has 10 facilities suited for physical modeling, ranging from 15,000 to 225,000 ft<sup>2</sup> (1,394 to 20,903 m<sup>2</sup>) in size, and has sump capacities from 7,000 to 974,246 gal (26.5 to 3,688 m<sup>3</sup>) of water. In total, the facility area is 726,343 ft<sup>2</sup> (67,480 m<sup>2</sup>) and the total sump capacity is 3,216,780 gal (12,177 m<sup>3</sup>) of water.

USBR oversees the Technical Service Center,<sup>67</sup> which provides technical assistance for water and power resources specific to USBR. USBR may also expand its science and engineering services to other federal agencies through interagency agreements, as well as with public and private entities through other types of cooperation. The Technical Service Center is organized in six service divisions that include civil and geotechnical engineering, electrical and mechanical engineering services, and environmental science. One

<sup>66</sup> <https://www.erdcd.usace.army.mil/About/>

<sup>67</sup> <https://www.usbr.gov/tsc/index.html>

of these divisions is the Engineering & Laboratory Services Division, which includes several testing laboratories used for hydropower testing:

- *The Concrete and Structural Laboratory* focuses on structural and material testing, with an emphasis on concrete. The engineering services of this lab are not limited to in-lab testing but also provide field assessments. Equipment and capabilities include the following:
  - Petrographic analysis
  - 5 million lb (22,241 kN) universal testing machine (compression and tension)
  - Concrete mix laboratory
  - Dynamic testing laboratory
  - Vibration laboratory
  - Aggregate and riprap testing
  - Freezing/thawing testing
  - Thermal properties laboratory
  - Environmental testing chambers (−10°F to 180°F, or −23.3°C to 82.2°C)
  - Relative humidity rooms at 50%, 70%, and 100% (fog room)
- *The Materials and Corrosion Laboratory* focuses on material selection and testing, environmental compliance, and environmental management, with an emphasis on metallic (and specifically corrosion control) and nonmetallic materials (composites and geosynthetics).
- *The Geotechnical Laboratory and field support* focus on geotechnical testing, including soil and rock used for the foundations and the structures owned by USBR. Specialized equipment and capabilities are used for lab and field testing and investigations and include the following:
  - Soils physical properties and compaction laboratory
  - Concrete and rock direct shear machines (50 and 300 kip shear capacity, respectively)
  - Cyclic triaxial and cyclic direct simple shear soils testing
  - Rock triaxial shear testing
  - Soil triaxial testing with  $K_0$  consolidation to develop stress history and normalized soil engineering properties parameters
  - Field cone penetration testing
  - Field standard penetration test energy measurements
  - Hydrogeologic field testing
  - Large-scale field density testing
  - Field vane shear testing
- *Hydraulic investigations and laboratory services* relate to hydraulic engineering and water resources, including protecting, operating, and maintaining essential hydraulic infrastructure of USBR, such as dams, canals, and rivers, while ensuring environmental protection. The services include the following:
  - Physical modeling (54,000 ft<sup>2</sup>, or 5,016.8 m<sup>2</sup>, indoor lab facility)
  - Computational fluid dynamics
  - Hydraulic channels for hydraulic structures and machine performance (e.g., spillways, gates and valves, hydropower turbines)
  - Dam safety
  - Flow measurements calibration and training
  - Fish studies and ecosystem health monitoring and improvement

- *The Ecological Research Laboratory* provides services and equipment for monitoring terrestrial and aquatic habitats, detecting invasive and endangered species, and protecting aquatic ecosystems.

The Technical Service Center is one of the most important and well-equipped centers for hydropower testing in the United States, and it will play a crucial role in the future of modern hydropower testing.

#### 4.2 MARINE ENERGY TECHNOLOGY TESTING NETWORK (TEAMER)

The list of facilities presented in Section 4.1 suggests that most of the existing hydraulic testing capabilities in the United States include mainly low- to zero-head facilities, such as open channel flumes, tanks, and basins. These hydraulic structures may not be able to satisfy all the hydropower testing requirements and may be suitable for only a few specific features that do not imply large water heads (e.g., immersed or flow-through tests). Conversely, these facilities are highly relevant for testing marine renewable energy (MRE) technologies (i.e., marine and hydrokinetic energy technologies).<sup>68</sup> These technologies are designed to convert the kinetic energy (i.e., the motion) of waves and currents (i.e., tides, ocean currents, and rivers) into electricity. Unlike conventional hydropower, which converts the potential energy of two water bodies at different elevations, MRE systems extract the kinetic energy of moving water to generate power and therefore do not require water impoundments. The operating principle and the turbine geometry for the current converters are similar to wind energy in that a driving flow (in this case, water) spins a (typically) three-bladed rotor connected to a generator, which converts the mechanical torque into electricity. Wave energy converters on the other hand harness the vertical motion of waves and have unique designs that are specific to the MRE industry. MRE technologies are outside the scope of this effort, but several potential linkages and overlaps between MRE testing and hydropower testing can be leveraged.

MRE technologies are in their early stages of development, especially when compared with other forms of renewable energies, and face several fundamental scientific and engineering challenges. For instance, unlike wind energy devices, MRE devices have not yet converged to a unique standardized design and mainly operate in harsh environments. These factors are the main causes of high development costs and a relatively low TRL. Therefore, DOE, through WPTO, continues to support transformative R&D initiatives and testing infrastructure. One of these initiatives was the creation of the TEAMER program,<sup>48</sup> aimed at improving and coordinating testing capabilities for marine energy technology across the United States. TEAMER was initiated and funded by DOE and is directed by the Pacific Ocean Energy Trust with the ultimate purpose of advancing marine energy technologies to market. As reported on the TEAMER website:

The TEAMER program has three over-arching goals:

1. **Access to testing infrastructure:** provide device developers with access to a wide range of pre-certified facilities at minimal cost and allow for a much faster and more streamlined integration of physical testing and validation into the design process.
2. **Access to world-class expertise:** pair technology developers with the nation's leading marine energy experts, providing desktop assistance and access to modeling tools and support.

---

<sup>68</sup> <https://www.energy.gov/eere/water/marine-energy-basics>

3. **Consistent testing protocols:** implement consistent testing protocols for use in the facility network and create a repository of marine energy performance data that will serve the industry as a whole.

The TEAMER management team comprises WPTO, the Pacific Ocean Energy Trust (which directs TEAMER), NREL, PNNL, SNL, and the national MRE centers (Southern National Marine Renewable Energy Center, Pacific Marine Energy Center, and Hawai‘i National Marine Renewable Energy Center).

By initiating and supporting TEAMER, WPTO has made funding available that can be accessed by stakeholders interested in testing MRE technologies in partnership with testing facilities included in the network. Potential applicants come from different areas of MRE R&D and may be part of industry, academia, government, non-for-profit, and other types of organizations. DOE and national lab facilities are not allowed to participate as applicants but may serve as hosting network facilities. The Pacific Ocean Energy Trust continuously reviews and qualifies facilities to include in the network, which encompasses several testing facilities and capabilities across the United States in the following categories:

- Numerical modeling and expertise
- Laboratory and bench testing
- Tank, flume, tunnel, and basin testing
- Open water testing and expertise

Several facilities mentioned in Section 4.1 are in the TEAMER network. Applicants that seek testing support are required to identify the testing facility and discuss the feasibility of the co-developed project before applying for funding. The Requests for Technical Support calls are scheduled 2–3 times per year to allow 4–6 months of planning in between. Applications are reviewed by a team of technical experts selected by the TEAMER management team to assess feasibility and impact. If the project is selected, applicants and facilities must collaboratively create a detailed test plan, and funding will be distributed to the testing facility (not the applicants). Funding is contingent on shared acceptance of the detailed test plan by the applicant, the hosting facility, and the TEAMER program. The applicants and the facility must also agree upon collaboration terms such as IP, nondisclosure agreements, and insurance liability.

TEAMER is budgeted for approximately \$16 million, subdivided into administration costs (6%), engineering and technical expertise (30%–42%), and test facility access (52%–64%). The program started in 2019 and was originally scheduled to last 3 years (but may be extended), with the expectation to fund more than 100 projects. In each round of calls, TEAMER is anticipated to provide more than \$1 million in support, with awards ranging between \$25,000 and \$250,000. The magnitude of the award is proportional to the type of testing, with open tests potentially being the most expensive. These projects have a duration between 2 weeks and 9 months, thus implying narrow scoping and specific testing. Costs vary based on the facility type and rates; for example, hydraulic tests in channels and tanks might take a few weeks of intensive facility use at a high daily rate, whereas numerical simulations may last several months at a relatively lower daily rate.

From a technology development perspective, the main contribution of a testing network program such as TEAMER is the access to DOE funding for testing activities, the access to state-of-the-art testing facilities, and the coordination and standardization of these capabilities throughout the United States. A similar network program for conventional hydropower would strongly improve any technological innovation that requires validation and seeks testing integration in the design process.



## 5. OPPORTUNITIES TO ADVANCE HYDROPOWER TESTING

Sections 1 through 4 document the results of a scoping study intended to inform WPTO and its stakeholders about the role of testing facilities and capabilities in the current and future research, development, demonstration, and deployment of innovative hydropower technology. This section aims to highlight the testing gaps for hydropower innovations. Testing gaps are the testing challenges that cannot be met by existing testing capabilities. The gaps, summarized in Section 5.1, were identified by comparing the future trends of the industry (Section 1), the innovations and thematic challenges (Sections 2 and 3), and the available existing testing capabilities in the United States (Section 4). Two initiatives, a hydropower testing network and a hydropower test facility investment program, are proposed in Section 5.2 to address these gaps.

### 5.1 SUMMARY OF TESTING NEEDS AND FUTURE REQUIREMENTS

Section 3 identified four thematic challenges associated with testing hydropower innovations that future testing investments may seek to address: (1) full-scale testing, (2) validation of environmental mitigation technology, (3) hydropower flexibility testing, and (4) advanced materials and manufacturing development and testing. These four themes emerged individually while analyzing the technological innovation trends and the stakeholders' inputs collected through the RFI (Appendix C). The need for full-scale testing, in particular, was identified to (i) mitigate the risk associated with innovations for first adopters, (ii) investigate environmental interactions that cannot be validated at model scale, and (iii) test the complexity of design, operation, and maintenance of innovations that would be evident only at full scale. Therefore, full-scale testing also covers the other three challenges. Nevertheless, specific needs that fall under Themes 2, 3, and 4 could be separately addressed using existing small- or partial-scale capabilities at dedicated testing laboratories introduced in Section 4. For example, hydropower components fabricated with nonconventional materials and advanced manufacturing techniques (e.g., a turbine blade made of composite material) could be initially tested at existing laboratories to determine the material properties and all the required metrics (e.g., strength, resistance, etc.) without the need for a fully dedicated hydropower testing facility. However, the same component may eventually have to be tested in a full-scale system and quasi-operating conditions to fully validate its performance and reliability and reassure first adopters.

The examples of validating questions presented for each physical design categories in Section 3 suggest that combinations of all testing factors (water condition, scale, system completeness, variance of ambient conditions, and response characterization) are needed to address the testing challenges that will be introduced by technological innovations. Figure 4 shows that testing scale and water conditions might have priority in the combination of these factors. As described in Section 4, existing testing capabilities in the United States can currently cover several hydropower testing needs at the model scale with combinations of the other test factors (Figure 4), or at full scale but only for few isolated components (e.g., a generator tested using a dynamometer). However, full-scale, flow-through testing opportunities currently are not easily available. In fact, Section 4 describes that the hydraulic capabilities in the United States include only low- and zero-head facilities, namely open channels and wave- or tow-tanks. Therefore, water heads can only be simulated in physical modeling with components at partial scales. However, hydraulic functionality is almost always required to fully test the whole hydropower technology landscape (except for pure mechanical and electrical testing), especially to meet the needs expressed in all four themes. Therefore, full-scale hydraulic capabilities (i.e., head and flow) will be required to completely address the described challenges.

To identify the general requirements for such full-scale, flow-through facilities, the general trends of the hydropower development introduced in Section 1.3 must be considered. In summary:



1. Future hydropower development will mostly target low-head sites (<30 ft, or 9.1 m, of head) from NSDs, NPD retrofits, and upgrades of the existing fleet. This category of hydropower development may fall under the conventional classification of *small hydropower*. Conversely to large hydropower, small hydropower technology is less established and very expensive compared with the potential revenue. Therefore, technology validation initiatives are needed to optimize the development costs while minimizing the environmental footprint.
2. Rehabilitation of existing structures will create a variety of new technological and manufacturing opportunities that will also require new validations to assess efficiency, cost effectiveness, and structural safety. Therefore, new testing initiatives will have to include validation for new, unconventional materials and manufacturing techniques.
3. New developments require higher environmental performance standards, so efficient and cost-effective environmental mitigation technologies will have to be introduced and validated. This will lead to specific environmental testing capabilities that will need to be met at any scale.
4. The increasing adoption of other variable renewable resources and distributed energy systems will require hydropower technologies to be increasingly flexible and dispatchable, which implies a need for more pumped storage hydropower and more variable operations (start-up, ramping, shutdown, and other transient conditions). This will likely result in extended duration of testing activities and monitoring of dynamic and trended measurements.

All the described hydropower development trends, which will translate in testing facility desired features and specifications, are aligned with the four thematic challenges introduced in Section 3, confirming that testing needs follow the same path of technological innovation.

## 5.2 FUTURE TESTING OPPORTUNITIES

Based on the arguments resulting from this scoping report and summarized above, two initiatives have been identified by ORNL as having the greatest potential impact toward improving innovative hydropower technology testing:

- **Initiative 1:** Hydropower testing network program
- **Initiative 2:** Hydropower test facility investment

These two initiatives are meant to be complementary and together address all the gaps summarized. Together, the initiatives would provide valuable additional renewable energy testing capabilities to the United States and would benefit from federal agency coordination and execution. Additional analysis of these opportunities is warranted to ensure that investments are technically and financially defensible. The initiatives are described in more detail in the following sections.

### 5.2.1 Initiative 1: Hydropower Testing Network Program

Most importantly, the existing testing capabilities in the United States must be leveraged and coordinated. As identified in Section 4, a variety of existing test facilities within the United States currently support hydropower testing. This report highlights how model testing of most of the technological landscape (i.e., testing a technology at a reduced scale) can be addressed by existing facilities. In particular, as already mentioned in Section 5.1, some specific validation tests that address Themes 2, 3, and 4 can be performed leveraging existing laboratories and equipment in the United States. Cataloging these test facilities and associated capabilities would provide a valuable resource to technology developers looking to validate their design. A testing network program could serve to match testing needs with existing testing

capabilities, similar to how WPTO's TEAMER program operates for marine energy (Section 4.2), effectively coordinating future testing initiatives and supporting technology developers. A federally sponsored program could provide the initial funding much needed to small- to medium-sized development organizations to validate their proposed technology. Developers often do not have the internal testing capabilities nor the financial resources to optimize their designs, and they might not be aware of available opportunities, resulting in a major roadblock for their development and preclusion from market approach. Furthermore, a dedicated testing network would improve the development and dissemination of testing standards, thus supporting the conversation between stakeholders and regulators on regulatory requirements. Finally, simulation capabilities should also be included in such networks in addition to physical technology testing to support virtual validation of design objectives.

Any hydropower-centric testing network should aim to leverage structures and lessons learned from the TEAMER program while acknowledging the mature nature of the hydropower industry (i.e., certain design objectives and constraints are already well understood). A testing program would facilitate the collaboration with and among private facilities, federal agencies and infrastructure, universities, national laboratories, and any federal testing centers proposed in Initiative 2. Potential collaboration examples include conferences, tours, and fellowships programs to educate and train the future workforce.

Such a program should also consider whether support should be limited to technology development or whether site deployment could also be supported. One outcome of the WPTO RFI and this review is the need for in situ testing capabilities. In particular, environmental technologies must accommodate a host of environmental conditions that are difficult to replicate in laboratory- or partial-scale conditions. Testing of fish passage and other biota may also present the risk of introducing nonnative species to testing environments. Regulators often require environmental studies as part of the licensing and commissioning studies, so it is feasible to conduct research and testing at new projects, existing projects, or test stands outside of the testing facilities described in Initiatives 1 and 2. Mobile testing capabilities could enable in situ testing and greatly expand the scope of testing applications. Examples of mobile testing capabilities could include fish tagging and telemetry systems, advanced underwater imaging/sensing technologies, and turbine/structural health monitoring equipment. Mobile testing could reduce the costs for technology developers to bring equipment to a federal testing facility and provide the opportunity for research staff to collaborate with industry pilot and demonstration projects. The primary focus of testing within this report involves early-stage (TRLs 1–7) technologies, which typically employ lab testing. However, first adoption and stakeholder acceptance have been significant barriers to entry even for late-stage (TRLs 8 and 9) technologies that have been laboratory-tested. Mobile testing of late-stage technologies could incentivize developers, insurers, regulators, and other stakeholders to become first adopters. Additionally, future innovations must understand the performance of technologies in the field, so expanding the scope of testing through mobile capabilities may be important.

A hydropower testing network program is envisioned to be comparable to the current budget of the TEAMER program, which is approximately \$16 million, or more if it is extended (Section 4.2). While leveraging TEAMER's experience would help reduce the costs, hydropower is currently a larger industry than marine energy, and technological innovation might require new investments, such as the creation of additional assets for full-scale testing that are currently not available. Therefore, investment in a testing network program dedicated solely to hydropower is envisioned to be on the same order of magnitude as the TEAMER investment (i.e., tens of millions).

### **5.2.2 Initiative 2: Hydropower Test Facility Investment**

Section 5.1 discusses the need for a facility that could test emerging hydropower technologies at full scale by comparing the future testing challenges and the current suite of hydropower testing capabilities within the United States. Specifically, the four themes highlighted in Section 3.2 suggest the need for a facility

that can (1) validate a proposed design at full scale with flow-through capacity, (2) track transient and dynamic responses for a prolonged duration of time, (3) provide monitoring of environmental metrics, and (4) support the validation of unconventional material and manufacturing techniques. However, the definition of *full scale* in the hydropower industry can lead to a wide range of technology sizes and capacities. Notably, this report focuses on the needs of *small hydropower*, as justified by the general trends of future hydropower development summarized in Section 1.3. While large hydropower benefits from well-established designs and validation processes within the commercial segments of the hydropower industry, small hydropower is relatively underdeveloped and requires additional attention to optimize costs and environmental acceptability. To become feasible, small hydropower innovations need to reduce capital costs (dollars per kilowatt), construction and development schedules, and environmental impacts, all without the benefit of existing wide scale deployment. Full-scale validation is envisioned to encourage developers to first adopt innovative small hydropower technologies by decreasing the associated economical and technical risks. Nevertheless, testing activities for small hydropower represent critical financial burdens for developers when compared with the potential revenues. For this reason, governmental support on establishing dedicated testing facilities for emerging small hydropower technologies is highly desired. The initial governmental support may ideally cover some one-time capital costs, including scoping, design, construction, and commissioning. After the establishment of a test facility, some further merit-based incentive awards should be available to encourage the use of test facility by the hydropower industry. An ideal test facility site should possess most desired features to reduce the overall cost and best use of available resources.

The desired characteristics of a full-scale testing facility can be established by quantifying and prioritizing the trends and opportunities of future small hydropower development. Specifically, a set of desired characteristics, or criteria, can be drawn by comparing the testing challenges and future hydropower development trends as summarized in Section 5.1. Meeting all the listed criteria might be challenging and thus a potential facility might not be able to host all the desired features. In this regard, investments in *multiple* full-scale facilities might also be considered. Furthermore, practical and logistical challenges might arise when these general guide lines are translated into engineering designs. The following criteria and the example matrices in Appendix B are based on information from the review of hydropower testing and the RFI. Appendix B provides an example for scoring candidate facilities according to a risk-based decision matrix approach.

#### ***Criterion A. Head capability***

The head capability describes the maximum hydraulic head condition, the availability of that head, and the range of heads that the candidate facility can create. The discussions of the hydropower opportunities and innovations highlight the need for sufficient head and flow to test technologies at full scale. In particular, the minimum and desirable flow and head capacities for a full-scale test facility should be influenced by the opportunities for site development in the potential US market for technology. Based on Figure 3a in Section 1.3 and the DOE-funded study by Kao et al. (2014), most (71%) of the potential for new development (NSD or NPD) lies in low-head sites (<30 ft, or 9.1 m, of head). Therefore, a new full-scale facility should target a max head capability of at least 30 ft (9.1 m), meaning the facility can create pressurized, flow-through conditions at 30 ft (9.1 m) of gross head using the head and tailwater elevations at the site and or additional equipment (e.g., pumps or valves). Higher head capabilities that enable more use cases are preferred, although specialized facilities may require less head to achieve their goals. The ideal facility should be capable of operating over a large range of heads (e.g., 1–30 ft, or 1–9.1 m) to accommodate different testing requirements. Depending on the facility type, gross facility head may vary temporally, so the ideal facility should have year-round availability for the max head capability.

### **Criterion B. Flow capability**

The flow capability describes the maximum flow condition, the availability of that flow, and the range of flows that the facility can create. Following the same rationale of identifying testing criteria based on expected development conditions, Figure 3b shows that 77% of the potential sites for NSD and NPD development are characterized by a  $Q_{30}$  (watershed flow average with a 30% exceedance) of less than 15,000 cfs (425 m<sup>3</sup>/s). The  $Q_{30}$  is the industry standard for powerhouse design flows and can be used as a default in place of site-specific design optimization. For a 30 ft (9.1 m) head site, that flow limit corresponds to approximately 38 MW of potential capacity, indeed confirming that most potential development can be categorized as small hydropower. However, the investment costs for a 15,000 cfs (425 m<sup>3</sup>/s) test facility would be substantial. Therefore, a smaller target flow capability might be considered, especially based on the expected rated power and number of turbine units, which depend on many project conditions, including flow variability and technology costs. In fact, powerhouses are commonly designed with multiple generating units to increase flexibility and reliability. In the case of a 15,000 cfs (425 m<sup>3</sup>/s) facility, the flow would likely be handled by several smaller units (e.g., 5 turbines of 3,000 cfs, or 85 m<sup>3</sup>/s). Table 9 highlights the turbine design flow ranges for several emerging turbine designs that target small hydropower. The maximum design flow for these designs is approximately 1,000 cfs (28 m<sup>3</sup>/s), and the minimum design flow is approximately 50 cfs (1.4 m<sup>3</sup>/s). In support of this rationale, Figure 3b shows that 38% of sites have a  $Q_{30}$  less than 3,000 cfs (85 m<sup>3</sup>/s). Considering these factors, a full-scale testing facility should target a maximum flow capability ranging between 1,000 and 3,000 cfs (28 and 85 m<sup>3</sup>/s) with larger flow capabilities being preferred to enable more use cases. Furthermore, although there are no examples of full-scale prototype testing, high flows might be required for testing technologies beside generation units, such as sediment by-pass, fish passage, and boat chutes, so the selected required flow is deemed reasonable. Specialized facilities, such as regional environmental testing centers, may require more or less flow depending on the testing objective. In addition to the maximum flow capability, the facility should be able to provide a wide range of flow conditions (e.g., 50–3,000 cfs, or 1.4–85 m<sup>3</sup>/s) and have year-round availability for the target flow capability.

**Table 9. Average hydraulic head and flow operating ranges of emerging small hydropower turbines**

<b>Turbine</b>	<b>Minimum design flow</b>	<b>Maximum design flow</b>	<b>Minimum design head</b>	<b>Maximum design head</b>
Natel Restoration Hydro Turbine <sup>23</sup>	~45 cfs (1.3 m <sup>3</sup> /s)	~1,060 cfs (30 m <sup>3</sup> /s)	6.6 ft (2 m)	66 ft (20 m)
Voith StreamDiver <sup>19</sup>	70 cfs (2 m <sup>3</sup> /s)	424 cfs (12 m <sup>3</sup> /s)	6.6 ft (2 m)	26 ft (8 m)
ANDRITZ HydroMatrix <sup>20</sup>	177 cfs (5m <sup>3</sup> /s)	459 cfs (13m <sup>3</sup> /s)	6.6 ft (2 m)	79 ft (24 m)
Amjet ATS-63 <sup>18</sup>	395 cfs (11.2m <sup>3</sup> /s)	925 cfs (26 m <sup>3</sup> /s)	7 ft (2.2 m)	50 ft (15.2 m)

In summary, an ideal dedicated hydropower full-scale testing facility should be able to create up to 30 ft (9.1 m) of hydraulic head and pass up to 3,000 cfs (85 m<sup>3</sup>/s). These ranges refer to maximum capability—the facility must also be able to create test conditions from near-zero head and flow up to these maxima. The selection of maximum capability will likely depend upon the availability of existing infrastructure and resources for facility development. Importantly, these head and flow capability requirements are significantly higher than existing hydropower testing facilities in the United States, as described in Section 4.

### **Criterion C. Testing duration and availability**

This criterion describes the maximum duration allowed for a given test, the number of tests that can be run simultaneously, and the temporal availability of testing. New technologies will require transient,

dynamic, and extended duration testing and measurement techniques to ensure safe operation with increasingly complex grid conditions. This requirement directly addresses the challenge identified in Theme 3 (i.e., the definition and validation of hydropower flexibility). Therefore, the facility should accommodate stakeholders with a variety of time and spatial requirements. Specifically, the facility should be accessible for a variety of testing durations, including short-term (days to weeks) and long-term (months) testing needs. Longer testing durations are preferred, assuming equal testing availability. The facility should be able to control head and flow over a continuous range and for extended duration, as well as simulate start and stop and transient conditions. This requirement is therefore dictated by the testing equipment, the business model, the physical accessibility of the facility, and the hydrology of the site (Criteria A and B).

#### ***Criterion D. Diversity of testing objectives and capabilities***

This criterion describes the number of objectives that can be tested at the site and the breadth of test factors that can be applied. The facility should be able to validate design objectives beyond just power generation. Specifically, the facility should accommodate the validation of environmental mitigation technologies and structures made with unconventional materials and manufacturing processes. Therefore, desired testing capabilities might include full-scale fish passage assessment and testing (e.g., fish tanks, biological sensors, fish tagging, biological lab), full-scale sediment transport capabilities and measurements (e.g., sediment feeder, sediment pumps, weigh pans, sediment storehouse), water quality assessment (e.g., dissolved oxygen, contaminants, lubricants), recreation passage testing (e.g., complex structures and flow conditions), hydropower foundation testing, and advanced manufacturing demonstrations. Although most of the test factors discussed in Section 1.4 are already captured by Criteria A, B, and C, an ideal facility should also include instrumentation and measurements capabilities that can address the ambient time variance and the response characterization (Section 1.4). This criterion directly addresses the challenges identified in Themes 2, 3, and 4 (i.e., the testing and validation of environmental mitigation technologies, the hydropower flexibility, and unconventional material and manufacturing). Notably, these examples of non-generation testing represent desired capabilities and not strict requirements. However, potential availability of a more diverse set of testing capabilities will increase the suitability of a facility.

#### ***Criterion E. Accessibility and regionality***

This criterion describes the ability of personnel and equipment to easily access the site and how well the site represents development conditions. The facility should be easily accessible and available for testing year-round (e.g., free of ice issues in the winter for intakes). The equipment time available should satisfy the demand from users that cannot be met by existing facilities, such as those within the proposed testing network (Initiative 1). The location should provide reasonable access to nationwide stakeholders (close to an airport) and to large equipment (physical accessibility). The facility should also be accessible from a security standpoint; if a security clearance is needed, testing retrofit opportunities might be curtailed or even denied. The testing facility might be preferably located in regions with high hydropower development and/or development potential, as highlighted in the 2020 National Hydropower Map by HydroSource.<sup>69</sup> This would facilitate the connection between testing activities and technological innovation and ensure that tested environmental conditions are representative of the development region. This opportunity opens to the possibility of having different testing facilities in different representative regions of the United States.

---

<sup>69</sup> <https://hydrosorce.ornl.gov/map/2020-national-hydropower-map>

### ***Criterion F. Regulatory and operational impact***

This criterion describes the likelihood of facility development success and the impacts of the added testing capabilities on existing operations/purposes. The facility should be expected to meet federal, state, and local licensing requirements and minimize negative impacts on the operation of existing infrastructure. Potential retrofits must not affect licensed/intended operations of the existing facility, so locations with purposes no longer in operation may be advantageous. The facility should not significantly interrupt local recreation without consideration for mitigation. The facility should also minimize the environmental impacts of any developments. It should have a reliable source of water for testing purposes and should be able to support hydraulic and biological testing with minimal negative impacts to endangered species or local habitat. Facilities with opportunities to improve the current ecological condition with added hydropower testing capabilities may provide additional value.

### ***Criterion G. Cost effectiveness***

This criterion describes the costs to develop and maintain the facility, as well as the revenue potential of the project. The facility should use the lowest-cost alternatives to meet the performance goals of the project. The proposed retrofits should be sought to minimize budget and maximize flexibility and function, so sites with adequate existing electrical infrastructure, internet connection, and minimal required civil works are preferred. In addition, facilities with revenue mechanisms that do not impose significant user costs, such as energy sales from powertrain testing or parallel operations, are preferred to ensure the maintainability of the project.

This list of criteria represents an envelope of specific desired features that a full-scale facility should have. Again, a facility might not be able to meet all the criteria at once. Based on their relative importance, these criteria could be prioritized, and ranges of compatibility could be proposed. Appendix B provides an example prioritization methodology that uses these criteria to create quantitative scores for candidate facilities. In addition, several other features could promote the value of the test facility outside of the envelope described by these criteria. For example, the test facility could serve as a hub for hydropower workforce development through education or training rotation programs for students and industry professionals. The test facility could also facilitate industry engagement and the dissemination of research through conferences, events, and or business incubation programs. Coordination and development of these programs will depend on the guidance of WPTO and the stakeholders selected to design, own, and operate the test facility. The following section proposes developing the test facility at an existing federal facility because it is expected to have the lowest cost and shortest timeline for meeting the testing needs captured in this report. However, other options exist for the development of these testing capabilities, including construction of a greenfield facility, investment in field demonstration projects, expansion of existing laboratory facilities, and mobile testing infrastructure. The implementation of this initiative will depend on the strategic goals of WPTO as they relate to meeting the testing needs of the hydropower industry.

## 6. THE CASE FOR LEVERAGING FEDERAL WATER INFRASTRUCTURE

Initiative 2 describes a federal investment program that targets the development of one or more hydropower test facilities to fill the US hydropower innovation testing gaps. Section 5.2.2 also proposes several desired features (criteria) that a testing facility should include. This section proposes leveraging existing federal water infrastructure as new dedicated hydropower testing facilities. Based on the criteria, there are several possible benefits for retrofitting existing federal infrastructure to host full-scale testing capabilities.

- Using existing infrastructure inherently enables full-scale, flow-through testing, as indicated in Theme 1. Existing structures may in fact already meet the head and flow requirements of Criteria A and B.
- It may reduce civil works costs and environmental impacts of development compared with NSD, which would make the retrofit more cost-effective (Criterion G).
- It may employ existing federal expertise, providing centralized resources and personnel.
- It may be located in regions where hydropower is highly developed, making the testing activities well connected to technology developers, plants owners, and other stakeholders (Criterion E).
- It creates an opportunity to provide additional value and investment to the existing infrastructure through rehabilitation and retrofits.
- It may simplify the licensing and permitting processes since federal projects are self-regulating, and multiple agency approvals, including FERC, would not be required (Criterion F).
  - Section 23(b)(1) of the Federal Power Act<sup>70</sup> establishes Federal Energy Regulatory Commission (FERC) jurisdiction over “any person, association, corporation, State, or municipality” that undertakes “for the purpose of developing electric power, to construct, operate, or maintain any dam, water conduit, reservoir, power house, or other works incidental thereto across, along, or in any of the navigable waters of the United States, or upon any part of the public lands or reservations of the United States (including the Territories), or utilize the surplus water or water power from any Government dam.” Test facility development, construction, and operation undertaken solely by DOE, or the federal agency that owns and operates the encompassing infrastructure and reservation, would appear to avoid this FERC jurisdiction. However, if nonfederal owners or DOE contracts are involved in construction, operation, or maintenance of the facility, there may be a need to determine whether these activities do invoke FERC jurisdiction or the jurisdiction of other federal agencies (e.g., a USBR lease of power privilege or use authorization). The development and operation of a test facility in any case would be a federal action requiring environmental assessment under the National Environmental Policy Act, including appropriate categorical exclusions.

However, several challenges also exist, including that testing activities must not interfere with the licensed/intended purpose of the existing infrastructure (unless already decommissioned), the need for staffing personnel to operate the facility, specifying funding sources, and obtaining multi-agency

---

<sup>70</sup> [https://www.energy.gov/sites/prod/files/2019/10/f67/Federal%20Power%20Act\\_2019\\_508\\_0.pdf](https://www.energy.gov/sites/prod/files/2019/10/f67/Federal%20Power%20Act_2019_508_0.pdf)

approvals. Nevertheless, the benefits are expected to outweigh the challenges when compared with a public-private partnership, which could fall under the testing network of Initiative 1.

The next sections use publicly available data to provide an overview of potential suitability of existing federal infrastructure as hydropower testing centers according to Criteria A and B presented in Section 5.2.2, namely the available head and flow (as a first order approximation). Section 6.1 describes the population characteristics for four main project classes of existing infrastructure that are likely to meet the criteria. Section 6.2 offers a high-level cost estimation for the potential retrofitting of the four main project classes.

## 6.1 OVERVIEW OF US FEDERAL INFRASTRUCTURE BY CATEGORY

Existing infrastructure candidates are federally owned water control structures that could be retrofitted to provide hydropower testing capabilities. This report is not intended to recommend development of any particular site or group of sites because more information is needed to determine whether testing retrofits are legally, economically, and technically feasible. In particular, USBR and USACE are not authorized to repurpose existing projects without first coordinating with the customers, operating partners, and other stakeholders that the project serves. Per Criterion F, the testing retrofit must not interfere with authorized purposes and existing operations. Opportunities may exist to retrofit federal after consultation processes or as the authorized purposes change over time, so these USACE and USBR facilities were included in the following analysis.

Retrofits could take many forms based on the selected testing capabilities but would likely include technologies that provide controllable head and flow conditions to one or more testing bays, adding additional measuring/monitoring instrumentation, and creating customizable interconnection stands for temporary technological installment. These retrofits could entail significant additional civil works and electrical infrastructure, so potential costs and benefits depend largely on the characteristics of the selected candidate(s). This report aims to narrow the search for potential infrastructure by filtering sites on high-level characteristics based on the Criteria A and B from Section 5.2.2. These characteristics are subject to change as the testing needs, testing capabilities, and goals of the projects evolve.

Based on the criteria, several classes of federal infrastructure were identified as likely being suitable as testing facility. The classes include existing hydropower plants, navigation locks, NPDs, and canals/conduits. The following sections describe the rationale for these classes and data-driven summaries of the existing infrastructure. Data on the following infrastructure classes were gathered from a variety of data sources managed by ORNL, including the Existing Hydropower Assets database<sup>71</sup> on HydroSource,<sup>72</sup> and the NPDamCat tool,<sup>73</sup> which compiles a variety of NPD related data sets such as the National Inventory of Dams<sup>74</sup> (related documentation from Carter et al. 2022). The data were then filtered according to the criteria described in Table 10 that reflect the desired features from Section 5.2.2 (specifically, Criteria A and B) to obtain an example list of candidate sites. The criteria are not absolute and are only meant to facilitate a high-level overview of the characteristics of likely suitable infrastructure. However, the information available for each of the classes differs, so different filtering approaches were required. For example, NPDamCat provides flow and structural height information for NPDs and navigation locks, the Existing Hydropower Assets database provides plant capacity for existing hydropower plants, and there were no available databases for canals/conduits. Because of the lack of data

---

<sup>71</sup> <https://hydrosorce.ornl.gov/dataset/EHA2021>

<sup>72</sup> <https://hydrosorce.ornl.gov/>

<sup>73</sup> <https://npd-data.ornl.gov/>

<sup>74</sup> <https://nid.sec.usace.army.mil/#/>



for canals/conduits, Section 6.1.4 briefly describes several regional resource assessments that evaluated the potential for installing hydropower at existing canals/conduits.

**Table 10. Criteria used for high-level filtering analysis of potential federal infrastructure candidates**

Class	Criteria	Rationale
All	Sites must be owned by a federal agency (primarily USACE, USBR, and TVA).	Federal ownership may simplify the development process of constructing federal testing infrastructure.
	Sites must be located within the contiguous United States.	Siting candidate facilities within the contiguous United States would enable easier accessibility, particularly for large equipment.
Existing hydropower plants	Sites must have at least 2.5 MW of capacity.	Head and flow information is not publicly available for existing hydropower plants, so capacity was used as a proxy. The minimum capacity constraint of 2.5 MW reflects the head and flow targets of Criteria A and B. Using the hydropower equation ( $P = \rho gQH$ ), values of 30 ft (9.1 m) of head and 1,000 cfs (28 m <sup>3</sup> /s) of flow would approximately represent a 2.5 MW facility. Larger facilities could be expected to cost-effectively create head and flow conditions less than the rated conditions with less impacts on facility operation compared with smaller plants, so a maximum capacity is not applied.
NPDs and navigation locks	Sites must provide a nominal hydraulic head of at least 30 ft (9.1 m).	Based on Criterion A, hydraulic head capabilities of at least 30 ft (9.1 m) are desired for future testing. NPDs and existing plants likely have limited ability to cost-effectively increase head from the existing conditions since additional pumps and energy would be necessary. Valves, locks, or intake/outlet designs could effectively reduce head without additional energy requirements, so a maximum head is not set. Head estimate values were gathered from NPDamCat. <sup>73</sup>
	Sites must have a 70% exceedance flow greater than 1,000 cfs (28.3 m <sup>3</sup> /s).	Based on Criterion B, a flow capability of at least 1,000 cfs (28.3 m <sup>3</sup> /s) is desired for future testing. To ensure sufficient availability throughout the year, the 1,000 cfs (28 m <sup>3</sup> /s) is constraint is applied to the Q <sub>70</sub> (the flow that is exceeded 70% of the time). Flow estimates were gathered from NPDamCat, although flow percentile information was not available for all US NPDs.
Canals and conduits	N/A	Because data on point-based canal and conduit potential were limited, canals and conduits were excluded from the analysis. More details are given in Section 6.1.4.

The results of the classification analysis are illustrated in Figure 10. Approximately 190 sites were identified using these filters. This analysis did not include canal/conduit infrastructure, described in Section 6.1.4, but did include existing hydropower plants (indicated by squares), navigation locks (indicated by triangles), and other NPDs (indicated by circles). The results for each class are described in the corresponding sections.

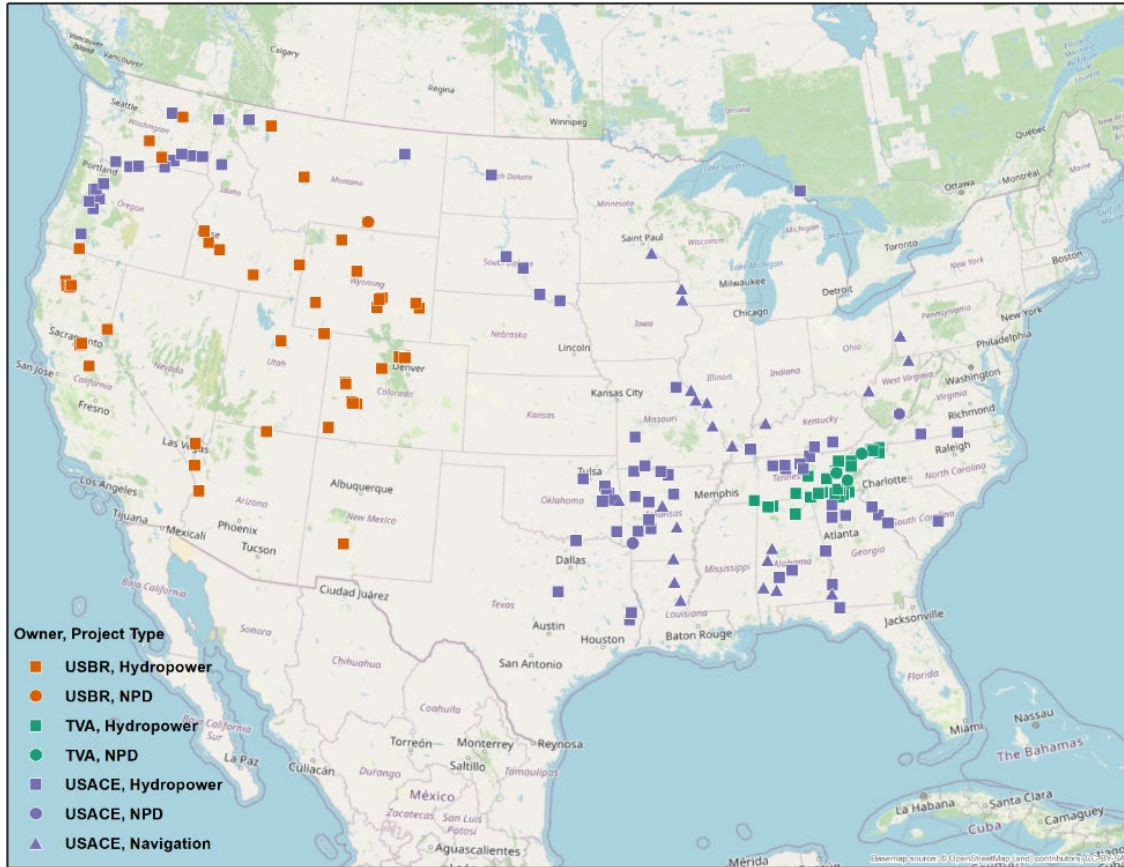

**Figure 10. Map of federally owned infrastructure identified as potential candidates for testing facility retrofits.**

### 6.1.1 Existing Hydropower Plants

To test hydropower technologies, it may be beneficial to locate testing capabilities at existing hydropower plants that have the capability to create full-scale, flow-through, facility-level conditions. Testing capabilities could be added by integration into existing units or by installing equipment in unused conveyances. Additionally, these facilities likely have suitable electrical infrastructure and experienced personnel to support retrofits. There are approximately 2,300 operational hydropower plants in the United States described in the Existing Hydropower Assets database from HydroSource. The capacity minimum of 2.5 MW was set to represent the head and flow requirements of Criterion A and B but not exclude larger plants than can likely support the head and flow needs. After applying the filters, 157 federal hydropower plant candidates were identified (squares in Figure 10). The hydropower plants are all owned by USBR, USACE, and TVA. The subset of plants exhibits a variety of locations, operating modes, and dam types.

The primary challenge will be retrofitting an existing plant without significantly altering energy generation, capacity, or other operational requirements. Depending on the retrofit designs, testing capabilities could alter the head and flow available for generation, require increased outages, add safety concerns, or interrupt environmental flows. Particularly at USACE and USBR facilities, testing capabilities could not likely be added to existing plants without interruption to the preexisting purposes, which would preclude the possibility to repurpose these hydropower plants. Within the 157 candidate hydropower sites, USACE accounts for 75 sites (21 GW total), and USBR accounts for 53 sites (14 GW

total). Although the likelihood of development at USACE and USBR facilities is low during their current operational timelines, the facilities were included to consider the potential of retrofitting facilities as part of future rehabilitation efforts or collaborations with the research branches of either institution. Within the sample of 157 plants, the average starting operation year was 1957, the oldest plant was built in 1912, and the newest plant was built in 2004. Given the typical project life of 50 to 100 years, testing capabilities may be retrofitted as part of rehabilitation or relicensing efforts as plants reach the end of their design life.

### **6.1.2 Navigation Locks**

Navigable rivers consist of a series of dams creating the necessary draft, or water depth, for floating vessels. Navigation locks are located at the dams to create vertical chambers for boats to move to the corresponding water elevation upstream or downstream of the dam. The navigation lock consists of a gated chamber that is filled and drained to match the headwater or tailwater elevations. The equipment to fill and drain the lock chamber may provide useful testing capabilities. The primary challenge for locks is that testing must not interfere with existing navigation routes. Therefore, testing retrofits should likely be installed on nonoperational (decommissioned) locks or at a site with multiple locks that can facilitate testing and navigation simultaneously.

The data for navigation locks and dams were derived for NPDamCat, and the analysis identified 26 navigation structures with a total of 28 locks across these facilities. All of these locks are owned by USACE, and several are located along the Mississippi River. Sequential sites such as these are unlikely to be able to support testing without losses to navigation availability.

### **6.1.3 NPDs (Non-Navigation)**

More than 84,000 NPDs in the United States provide head and could be used for testing retrofits (Hadjerioua, Wei, and Kao 2012; Hansen et al. 2021). These NPDs provide a host of purposes, including recreation, water supply, and flood control. Because of the large number of NPDs, in theory, a greater chance exists of finding an NPD with a nonoperational primary purpose that could have added value from testing retrofits. Some NPDs, for example, were previously powered, meaning they used to provide mechanical or electrical hydropower but have been decommissioned, and the conveyance infrastructure is available to be repurposed. The primary challenges for NPDs include identifying suitable NPDs since the population is very diverse, and retrofitting testing capabilities in a cost-effective way. Since NPDs lack power capabilities, they are likely to require expensive civil works and electrical infrastructure.

Similar to the data in Section 6.1.2, the data for the NPD analysis were also gathered using NPDamCat. Approximately 3,311 NPDs were identified by limiting the population to federally owned NPDs that do not have navigation or hydropower as a primary purpose. After filtering for the >30 ft (9.1 m) of head and >1,000 cfs (28 m<sup>3</sup>/s) of the Q<sub>70</sub> (the flow that is exceeded 70% of the time) flow requirements, only 7 NPDs remained. This limited number is partially a result of data availability limitations for the head and flow exceedance values; 653 NPDs (19.7%) did not have head or flow data. The head constraint alone reduced the population to 593 sites (22% of sites with data), and the flow constraint further narrowed it to 7 sites (1% of sites with data). Although these criteria were applied strictly for the sake of this analysis, the list of criteria includes several other desired features that would allow sites that do not meet these criteria to be considered. Similar to the existing hydropower subset, this subset is largely owned by TVA, USACE, and USBR.

### **6.1.4 Canals and Conduits**

Outside of existing dam infrastructure, a variety of canals and conduit-like infrastructure could provide the water control capabilities needed for testing. The United States uses a variety of canals, dikes, tunnels,

and pipes to support irrigation, drinking water supply, and other industrial purposes. Hydropower can be generated using existing drops and pressure differentials in these systems. Although data on the characteristics of US canal and conduit infrastructure are relatively limited, USBR compiled a hydropower resource assessment that included the potential of its canals and conduits and indicated 225 MW of potential (including dam infrastructure) (US Bureau of Reclamation 2011a; 2012). ORNL also conducted an assessment of generation potential at public drinking water systems in Oregon and Colorado and identified 55 MW of capacity (Kao and Johnson 2018). A benefit of these systems is that they may have existing pumping infrastructure and engineered conveyances that could suit a variety of testing needs. Additionally, these engineered systems may have limited environmental impacts compared with dams in larger river systems, although the impacts may not be negligible. The primary challenges include not interrupting the existing functions and representing conditions at conventional hydropower plants. Testing retrofits should not impede head or flow in ways that could reduce the facilities' ability to meet water availability requirements. Additionally, many of these sites have lower flow and head than conventional dam infrastructure, and representing the desired conditions for small hydropower testing may be difficult.

## 6.2 COST ESTIMATION

Cost is an important consideration when selecting candidate infrastructure. The cost of retrofitting existing infrastructure for hydropower testing depends on many factors, including the selected testing capabilities, existing features, head and flow characteristics, and location. The desired capabilities and candidate facilities have not been selected, so cost estimates can only be high-level approximations. The empirical cost models described in Table 11 were derived from the 2015 Hydropower Baseline Cost Model report for a variety of hydropower development categories (O'Connor, Zhang, et al. 2015). This methodology assumed that the development of a hydropower test facility is similar to the cost to add hydropower capabilities to existing infrastructure. For example, the cost to create testing capabilities at an existing hydropower plant was modeled using the cost to add a new unit to the plant. The costs to retrofit navigation locks and NPDs were modeled as NPD retrofits. The cost to build a new hydropower facility at an NSD is included for comparison. The original empirical models were reported in 2014 US dollars as illustrated by the Original *a* column in Table 11. These coefficients were adjusted using an escalation factor of 1.2 to convert to 2021 US dollars and an additional adjustment factor of 1.3 to account for testing specific equipment and infrastructure. The escalation factor was calculated by comparing the yearly average composite indexes from USBR's Construction Cost Trends,<sup>75</sup> which aggregates the cost indexes for a host of hydropower-related construction items, such as dams, pipelines, and roads. The adjustment factor, which accounts for the cost deviation between a test facility and conventional hydropower development, will depend largely on the selected infrastructure and desired capabilities. An approximate 30% increase in cost was used to account for advanced testing equipment and multi-objective testing capabilities (Criterion D). The adjustment factor was applied across all cost categories (e.g., civil works, electrical infrastructure, electro-mechanical equipment, management) because a holistic test facility would enable testing across the physical design hierarchy.

---

<sup>75</sup> <https://www.usbr.gov/tsc/techreferences/mands/cct.html>

**Table 11. Empirical equations and coefficients used for cost estimation adapted from the 2015 Hydropower Baseline Cost Model Report (O’Connor, Zhang, et al. 2015).** *ICC* denotes initial capital cost; *O&M* denotes operations and maintenance; *P* denotes the expected power in megawatts; *H* denotes the nominal head in feet; and *a* denotes the empirical coefficient estimated by O’Connor, Zhang, et al. (2015)

Project type	Equation form	Original <i>a</i> (\$2014)	Adjusted <i>a</i> (\$2021)
Existing hydropower (unit addition)	$ICC = a P^{0.741}$	4,163,746	6,496,870
NPD	$ICC = a P^{0.976} H^{-0.240}$	11,489,245	17,927,158
Canal/conduit	$ICC = a P^{0.810} H^{-0.102}$	9,297,820	14,507,784
NSD	$ICC = a P^{0.977} H^{-0.126}$	9,605,710	14,988,198
All project type operations and maintenance	$O\&M = a P^{0.547}$	225,417	351,728

For the purpose of this scoping report, a cost estimate for a 7.6 MW facility with 30 ft (9.1 m) of head and flow of 3,000 cfs (85 m<sup>3</sup>/s) was calculated and is reported in Table 12. This design point is representative of the desired head and flow conditions discussed in Section 5.2.2. Additionally, Table 12 provides a cost estimate of NSD hydropower to represent the costs of building a test facility on a new site for comparison purposes. Based on these models, retrofitting an existing facility is expected to save approximately 20%–60% of installed costs compared with a new facility. The operations and maintenance costs also likely differ based on the selected capabilities, but the average operations and maintenance costs (adjusted) for all hydropower projects captured in the 2015 Hydropower Baseline Cost Model effort were used to provide a reference cost.

**Table 12. High-level cost estimates for retrofitting hydropower testing capabilities on existing infrastructure**

Project type	7.6 MW test facility estimate (\$2021)
Existing hydropower	30,000,000
Navigation lock	58,000,000
NPD	58,000,000
Canal/conduit	54,000,000
NSD	72,000,000
Annual operations and maintenance	1,100,000

## 7. REFERENCES

- Adam, N J, G De Cesare, C Nicolet, P Billeter, A Angermayr, B Valluy, and A J Schleiss. 2018. “Design of a Throttled Surge Tank for Refurbishment by Increase of Installed Capacity at a High-Head Power Plant.” *Journal of Hydraulic Engineering* 144 (2): 05017004. [https://doi.org/10.1061/\(ASCE\)HY.1943-7900.0001404](https://doi.org/10.1061/(ASCE)HY.1943-7900.0001404).
- Adam, N J, G De Cesare, and A J Schleiss. 2019. “Influence of Geometrical Parameters of Chamfered or Rounded Orifices on Head Losses.” *Journal of Hydraulic Research* 57 (2): 263–71. <https://doi.org/10.1080/00221686.2018.1454518>.
- Amaral, S V, S M Watson, A D Schneider, J Rackovan, and A Baumgartner. 2020. “Improving Survival: Injury and Mortality of Fish Struck by Blades with Slanted, Blunt Leading Edges.” *Journal of Ecohydraulics* 5 (2): 175–83. <https://doi.org/10.1080/24705357.2020.1768166>.
- ASME Hydro Power Technical Committee. 1996. *The Guide to Hydropower Mechanical Design*. HCI Publications. <https://www.pennwellbooks.com/the-guide-to-hydropower-mechanical-design/>.
- Auel, C. 2014. “Flow Characteristics, Particle Motion And Invert Abrasion In Sediment Bypass Tunnels.” *VAW Mitteilungen*. ETH Zurich.
- Aumelas, V, G Maj, P L Calvé, M Smith, B Gambiez, and X Mourrat. 2016. “A New Methodology for Hydro-Abrasive Erosion Tests Simulating Penstock Erosive Flow.” *IOP Conference Series: Earth and Environmental Science* 49 (November): 122012. <https://doi.org/10.1088/1755-1315/49/12/122012>.
- Bartock, M, J Brule, Y-S Li-Baboud, S Lightman, J McCarthy, K Reczek, D Northrip, A Scholz, and T Suloway. 2021. “Foundational PNT Profile:” Gaithersburg, MD. <https://doi.org/10.6028/NIST.IR.8323>.
- Bird, J, and W Williams. 2018. “Advanced High Torque Density Magnetically Geared Generator.” <https://doi.org/10.2172/1494152>.
- Bombardelli, F A, M Guala, C M García, B Briskin, and M H García. 2002. “Mean Flow, Turbulence, and Free-Surface Location in a Canoe Chute Physical Model.” In *Hydraulic Measurements and Experimental Methods*, 1–12. American Society of Civil Engineers. [https://doi.org/10.1061/40655\(2002\)12](https://doi.org/10.1061/40655(2002)12).
- Bonnet, M, Adam M. Witt, Boualem Hadjerioua, and M Mobley. 2015. “The Economic Benefits Of Multipurpose Reservoirs In The United States- Federal Hydropower Fleet.” <https://doi.org/10.2172/1237622>.
- Cai, F, Y-G Cheng, L-S Xia, and Y-Q Jiang. 2017. “Mechanism of Air-Trapped Vertical Vortices in Long-Corridor-Shaped Surge Tank of Hydropower Station and Their Elimination.” *Journal of Hydrodynamics* 29 (5): 845–53. [https://doi.org/10.1016/S1001-6058\(16\)60796-5](https://doi.org/10.1016/S1001-6058(16)60796-5).
- Caisley, M E, F A Bombardelli, and M H Garcia. 1999. “Hydraulic Model Study of a Canoe Chute for Low-Head Dams in Illinois.” Urbana, IL. <https://www.ideals.illinois.edu/handle/2142/12214>.
- Caisley, M E, and M Garcia. 1999. “Canoe Chutes and Fishways for Low-Head Dams: Literature Review and Design Guidelines.” Urbana, IL. <https://www.ideals.illinois.edu/handle/2142/12219>.
- Carter, Forest, Scott Deneale, Christopher Derolph, and Carly Hansen. 2022. “NPD Classification Tools – User Guide NPD Explorer and NPDamCAT Apps.” Oak Ridge, TN (United States). <https://doi.org/10.2172/1855640>.
- Colorado Water Conservation Board. 2008. “Hydraulic Analysis and Design.” In *Floodplain and Stormwater Criteria Manual*. Denver, CO: Colorado Department of Natural Resources.

- <https://cwcb.colorado.gov/public-information/technical-tools/floodplain-stormwater-criteria-manual>.
- Cook, T C, S A Cain, P Fetfatsidis, G E Hecker, and P S Stacy. 2000. “Final Turbine and Test Facility Design Report Alden/NREC Fish Friendly Turbine.” <https://doi.org/10.2172/1218145>.
- Deleau, M J C, P R White, G Peirson, T G Leighton, and P S Kemp. 2020a. “The Response of Anguilliform Fish to Underwater Sound under an Experimental Setting.” *River Research and Applications* 36 (3): 441–51. <https://doi.org/10.1002/rra.3583>.
- . 2020b. “Use of Acoustics to Enhance the Efficiency of Physical Screens Designed to Protect Downstream Moving European Eel ( *Anguilla Anguilla* ).” *Fisheries Management and Ecology* 27 (1): 1–9. <https://doi.org/10.1111/fme.12362>.
- DeNeale, Scott T., G B Baecher, K M Stewart, E D Smith, and D B Watson. 2019. “Current State-of-Practice in Dam Safety Risk Assessment.” Oak Ridge, TN, USA.
- DeNeale, Scott T., N Bishop, L Buetikofer, R Sisson, C Sasthav, M Musa, T Wilcox, K Stewart, Wi Tinggen, and C DeRolph. 2020. “Hydropower Geotechnical Foundations : Current Practice and Innovation Opportunities for Low-Head Applications.” Oak Ridge, TN (United States). <https://doi.org/10.2172/1649157>.
- Deng, Z D, T J Carlson, J P Duncan, and M C Richmond. 2007. “Six-Degree-of-Freedom Sensor Fish Design and Instrumentation.” *Sensors* 7 (12): 3399–3415. <https://doi.org/10.3390/s7123399>.
- Deng, Z D, T J Carlson, J P Duncan, M C Richmond, and D D Dauble. 2010. “Use of an Autonomous Sensor to Evaluate the Biological Performance of the Advanced Turbine at Wanapum Dam.” *Journal of Renewable and Sustainable Energy* 2 (5). <https://doi.org/10.1063/1.3501336>.
- Deng, Z D, J Lu, M J Myjak, Jayson J. Martinez, C Tian, S J Morris, T J Carlson, D Zhou, and H Hou. 2014. “Design and Implementation of a New Autonomous Sensor Fish to Support Advanced Hydropower Development.” *Review of Scientific Instruments* 85 (11): 115001. <https://doi.org/10.1063/1.4900543>.
- Electric Power Research Institute. 2007a. “Investigation of Hydro-Turbine Leading-Edge Shapes Favorable to Fish Survival.” Palo Alto, CA. <https://www.epri.com/research/products/1012561>.
- . 2007b. “Program on Technology Innovation: Redesign of the Alden/Concepts NREC Helical Turbine for Increased Power Density and Fish Survival.” Palo Alto, CA. <https://www.epri.com/research/products/00000000001014810>.
- . 2008. “Evaluation of the Effects of Turbine Blade Leading Edge Design on Fish Survival.” Palo Alto, CA. <https://www.epri.com/research/products/00000000001014937>.
- . 2011. “2010 Tests Examining Survival of Fish Struck by Turbine Blades.” Palo Alto, CA. <https://www.epri.com/research/products/00000000001024684>.
- Electric Power Research Institute, and US Department of Energy. 2011. “EPRI-DOE Conference on Environmentally-Enhanced Hydropower Turbines: Technical Papers.” Palo Alto, CA. <http://www.epri.com/abstracts/Pages/ProductAbstract.aspx?ProductId=00000000001024609%5Cn papers3://publication/uuid/67D1E074-4A79-46FD-9F3D-BE192C6FF739>.
- Federal Energy Regulatory Commission. 2017. “Chapter 14 Dam Safety Performance Monitoring Program.” In *Engineering Guidelines for the Evaluation of Hydropower Projects*, 188. <https://www.ferc.gov/industries/hydropower/safety/guidelines/eng-guide/chap14.pdf>.
- Foust, J, G Hecker, S Li, and G Allen. 2011. “Fish-Friendly Hydropower Turbine Development & Deployment: Alden Turbine Preliminary Engineering and Model Testing.” <https://doi.org/10.2172/1050066>.

- Gebhardt, M. 2013. “Inflatable Structures in Hydraulic Engineering.” In *Smart Rivers 2013*, 1–9. Maastricht (NL); Liege (BE): PIANC.
- Gisen, D C, R B Weichert, and J M Nestler. 2017. “Optimizing Attraction Flow for Upstream Fish Passage at a Hydropower Dam Employing 3D Detached-Eddy Simulation.” *Ecological Engineering* 100 (March): 344–53. <https://doi.org/10.1016/j.ecoleng.2016.10.065>.
- Gulliver, J S, and R E A Arndt. 1991. *Hydropower Engineering Handbook*. McGraw-Hill, Inc. <http://conservancy.umn.edu/handle/11299/195476>.
- Hadjerioua, Boualem, T Eldredge, H Medina, and Scott T. DeNeale. 2019. “Hydrodynamic and Structural Response Modeling of a Prototype Floating Membrane Reservoir System for Pumped Storage Hydropower.” *Journal of Hydraulic Engineering* 145 (9): 04019032. [https://doi.org/10.1061/\(ASCE\)HY.1943-7900.0001625](https://doi.org/10.1061/(ASCE)HY.1943-7900.0001625).
- Hadjerioua, Boualem, Y Wei, and S-C Kao. 2012. “An Assessment of Energy Potential at Non-Powered Dams in the United States.” *Hydropower and Energy Potential at Non-Powered Dams*. Oak Ridge, TN (United States). <https://doi.org/10.2172/1039957>.
- Hansen, Carly, M Musa, C Sasthav, and Scott T. DeNeale. 2021. “Hydropower Development Potential at Non-Powered Dams: Data Needs and Research Gaps.” *Renewable and Sustainable Energy Reviews* 145: 111058.
- Harding, S F, R P Mueller, M C Richmond, P Romero-Gomez, and A H Colotelo. 2019. “Fish Response to Turbulence Generated Using Multiple Randomly Actuated Synthetic Jet Arrays.” *Water* 11 (8): 1715. <https://doi.org/10.3390/w11081715>.
- Hogan, T W, G F Cada, and S V Amaral. 2014. “The Status of Environmentally Enhanced Hydropower Turbines.” *Fisheries* 39 (4): 164–72. <https://doi.org/10.1080/03632415.2014.897195>.
- Isaac, N, and T I Eldho. 2019. “Sediment Removal from Run-of-the-River Hydropower Reservoirs by Hydraulic Flushing.” *International Journal of River Basin Management* 17 (3): 389–402. <https://doi.org/10.1080/15715124.2019.1583667>.
- Itsukushima, R, S Ikematsu, M Nakano, M Takagi, and Y Shimatani. 2016. “Optimal Structure of Grated Bottom Intakes Designed for Small Hydroelectric Power Generation.” *Journal of Renewable and Sustainable Energy* 8 (3): 034501. <https://doi.org/10.1063/1.4948918>.
- Kao, S-C, and K Johnson. 2018. “An Assessment of Energy Potential at Public Drinking Water Systems: Initial Report on Methodology.” Oak Ridge, TN. <https://www.ornl.gov/file/assessment-energy-potential-public-drinking-water-systems-initial-report-methodology/display>.
- Kao, S-C, R A McManamay, K M Stewart, N M Samu, Boualem Hadjerioua, Scott T. DeNeale, D Yeasmin, M F K Pasha, A A Oubeidillah, and Brennan T. Smith. 2014. “New Stream-Reach Development : A Comprehensive Assessment of Hydropower Energy Potential in the United States.” *US Department of Energy Wind and Water Power Technologies Office*. Oak Ridge, TN (United States). [http://nhaap.ornl.gov/sites/default/files/ORNL\\_NSD\\_FY14\\_Final\\_Report.pdf](http://nhaap.ornl.gov/sites/default/files/ORNL_NSD_FY14_Final_Report.pdf).
- Khusankhudzaev, U, and A Jahonov. 2020. “Hydraulic Research Results for Cantilever Spillway at Hydroelectric Power Station 2 of Chirchik – Bossuv Waterway.” *IOP Conference Series: Materials Science and Engineering* 883 (1): 012055. <https://doi.org/10.1088/1757-899X/883/1/012055>.
- Kinloch, D B. 2015. “Demonstration of Variable Speed Permanent Magnet Generator at Small, Low-Head Hydro Site.” <https://doi.org/10.2172/1230014>.
- Kondolf, G M, Y Gao, G W Annandale, G L Morris, E Jiang, J Zhang, Y Cao, et al. 2014. “Sustainable Sediment Management in Reservoirs and Regulated Rivers: Experiences from Five Continents.” *Earth’s Future* 2 (5): 256–80. <https://doi.org/10.1002/2013ef000184>.



- Kougias, I, G Aggidis, F Avellan, S Deniz, U Lundin, A Moro, S Muntean, et al. 2019. “Analysis of Emerging Technologies in the Hydropower Sector.” *Renewable and Sustainable Energy Reviews* 113 (January): 109257. <https://doi.org/10.1016/j.rser.2019.109257>.
- Langston, J, M Steurer, K Schoder, J Hauer, F Bogdan, I Leonard, T Chiocchio, et al. 2012. “Megawatt Scale Hardware-in-the-Loop Testing of a High Speed Generator.” In *American Society of Naval Engineers*. <http://www.dtic.mil/docs/citations/ADA558395>.
- Levine, A, B M Pracheil, T Curtis, L Smith, J Cruce, M Aldrovandi, C Bresford, et al. 2021. “An Examination of the Hydropower Licensing and Federal Authorization Process.” Golden, CO (United States). <https://doi.org/10.2172/1827895>.
- Li, Huidong, Daqing Zhou, Jayson J. Martinez, Zhiquan Daniel Deng, Kenneth I. Johnson, and Matthew P. Westman. 2019. “Design and Performance of Composite Runner Blades for Ultra Low Head Turbines.” *Renewable Energy* 132 (March): 1280–89. <https://doi.org/10.1016/j.renene.2018.08.110>.
- Lindblom, K C, and J S Gulliver. 1983. “Hydraulic Model Study of the Rapidian Hydroplant Intake.”
- Maranzoni, A, M Pilotti, and M Tomirotti. 2017. “Experimental and Numerical Analysis of Side Weir Flows in a Converging Channel.” *Journal of Hydraulic Engineering* 143 (7). [https://doi.org/10.1061/\(asce\)hy.1943-7900.0001296](https://doi.org/10.1061/(asce)hy.1943-7900.0001296).
- Martinez, J.J., Z.D. Deng, P.S. Titzler, J.P. Duncan, J. Lu, R.P. Mueller, C. Tian, B.A. Trumbo, M.L. Ahmann, and J.F. Renholds. 2019. “Hydraulic and Biological Characterization of a Large Kaplan Turbine.” *Renewable Energy* 131 (February): 240–49.
- Martinez, Jayson J., Zhiquan Daniel Deng, Robert Mueller, and Scott Titzler. 2020. “In Situ Characterization of the Biological Performance of a Francis Turbine Retrofitted with a Modular Guide Vane.” *Applied Energy* 276 (October). <https://doi.org/10.1016/J.APENERGY.2020.115492>.
- Mulligan, K B, A Haro, B Towler, B Sojkowski, and J Noreika. 2019. “Fishway Entrance Gate Experiments With Adult American Shad.” *Water Resources Research* 55 (12): 10839–55. <https://doi.org/10.1029/2018WR024400>.
- Mulligan, K B, B Towler, A Haro, and D P Ahlfeld. 2018. “Downstream Fish Passage Guide Walls: A Hydraulic Scale Model Analysis.” *Ecological Engineering* 115 (May): 122–38. <https://doi.org/10.1016/j.ecoleng.2018.02.006>.
- O’Connor, P W, Scott T. DeNeale, D R Chalise, E Centurion, and A Maloof. 2015. “Hydropower Baseline Cost Modeling, Version 2.” Oak Ridge, TN (United States). <https://doi.org/10.2172/1244193>.
- O’Connor, P W, Q F Zhang, Scott T. DeNeale, D R Chalise, E Centurion, and A Maloof. 2015. “Hydropower Baseline Cost Modeling.” Vol. 471. Oak Ridge, TN (United States). <https://doi.org/10.2172/1185882>.
- Odgaard, A. J, and J F Kennedy. 1983. “River-Bend Bank Protection by Submerged Vanes.” *Journal of Hydraulic Engineering* 109 (8): 1161–73. <https://doi.org/10.1006/exer.1996.0214>.
- Odgaard, A J, and C E Mosconi. 1987. “Streambank Protection by Submerged Vanes.” *Journal of Hydraulic Engineering* 113 (4): 520–36. [https://doi.org/10.1061/\(ASCE\)0733-9429\(1987\)113:4\(520\)](https://doi.org/10.1061/(ASCE)0733-9429(1987)113:4(520)).
- Odgaard, A J, and Y Wang. 1991a. “Sediment Management with Submerged Vanes. I: Theory.” *Journal of Hydraulic Engineering* 117 (3): 267–267. [https://doi.org/10.1061/\(ASCE\)0733-9429\(1991\)117:3\(267\)](https://doi.org/10.1061/(ASCE)0733-9429(1991)117:3(267)).
- . 1991b. “Sediment Management with Submerged Vanes. II: Applications.” *Journal of Hydraulic Engineering* 117 (3): 284–302. [https://doi.org/10.1061/\(ASCE\)0733-9429\(1991\)117:3\(284\)](https://doi.org/10.1061/(ASCE)0733-9429(1991)117:3(284)).

- Oladosu, Gbadebo A., L George, and J Wells. 2021. “2020 Cost Analysis of Hydropower Options at Non-Powered Dams.” Oak Ridge, TN (United States). <https://doi.org/10.2172/1770649>.
- Oladosu, Gbadebo A., J Werble, W Tingen, Adam M. Witt, M Mobley, and P W O’Connor. 2021. “Costs of Mitigating the Environmental Impacts of Hydropower Projects in the United States.” *Renewable and Sustainable Energy Reviews* 135. <https://doi.org/10.1016/j.rser.2020.110121>.
- Orekhov, G. 2019. “Flow Kinematics with Oppositely Rotating Coaxial Layers.” Edited by A. Volkov, A. Pustovgar, T. Sultanov, and A. Adamtsevich. *E3S Web of Conferences* 97 (May): 05051. <https://doi.org/10.1051/e3sconf/20199705051>.
- Parish, E S, B M Pracheil, R A McManamay, S L Curd, C R DeRolph, and B T Smith. 2019. “Review of Environmental Metrics Used across Multiple Sectors and Geographies to Evaluate the Effects of Hydropower Development.” *Applied Energy* 238 (December 2018): 101–18. <https://doi.org/10.1016/j.apenergy.2019.01.038>.
- Peng, Y, J Zhang, W Xu, and M Rubinato. 2018. “Experimental Optimization of Gate-Opening Modes to Minimize Near-Field Vibrations in Hydropower Stations.” *Water* 10 (10): 1435. <https://doi.org/10.3390/w10101435>.
- Pflugrath, B D, R K Saylor, K Engbrecht, R P Mueller, J R Stephenson, M Bevelhimer, B M Pracheil, and A H Colotelo. 2020. “Biological Response Models: Predicting Injury and Mortality of Fish During Downstream Passage through Hydropower Facilities.” Richland, WA. <https://www.pnnl.gov/publications/biological-response-models-predicting-injury-and-mortality-fish-during-downstream>.
- Pracheil, B M, C R DeRolph, M P Schramm, and M S Bevelhimer. 2016. “A Fish-Eye View of Riverine Hydropower Systems: The Current Understanding of the Biological Response to Turbine Passage.” *Reviews in Fish Biology and Fisheries* 26 (2): 153–67. <https://doi.org/10.1007/s11160-015-9416-8>.
- Praslicka, B, M C Gardner, M Johnson, and H A Toliyat. 2021. “Review and Analysis of Coaxial Magnetic Gear Pole Pair Count Selection Effects.” *IEEE Journal of Emerging and Selected Topics in Power Electronics* 6777 (c): 1–1. <https://doi.org/10.1109/JESTPE.2021.3053544>.
- Salalila, A., Jayson J. Martinez, R. Elsinghorst, H. Hou, Y. Yuan, and Z.D. Deng. 2020. “Real-Time and Autonomous Water Quality Monitoring System Based on Remotely Operated Vehicle.” In *Conference: Global Oceans 2020: Singapore – U.S. Gulf Coast*, 1–5. Biloxi, MS. <https://www.osti.gov/biblio/1804738>.
- Saylor, R K. 2021. “Susceptibility of Riverine Fishes to Anthropogenically-Linked Trauma: Strikes from Hydropower Turbine Blades.” University of Tennessee. [https://trace.tennessee.edu/utk\\_graddiss/6666](https://trace.tennessee.edu/utk_graddiss/6666).
- Saylor, R K, P L Wang, M Bevelhimer, P Lloyd, J Goodwin, R Laughter, D Young, et al. 2021. “Creation of a Prototype Biomimetic Fish to Better Understand Impact Trauma Caused by Hydropower Turbine Blade Strikes.” *PeerJ Materials Science* 3: e16. <https://doi.org/10.7717/peerj-matsci.16>.
- Schleiss, A J, M J Franca, C Juez, and G De Cesare. 2016. “Reservoir Sedimentation.” *Journal of Hydraulic Research* 54 (6): 595–614. <https://doi.org/10.1080/00221686.2016.1225320>.
- Stanford University Uncommon Dialogue. 2020. “U.S. Hydropower: Climate Solution and Conservation Challenge.” <https://woods.stanford.edu/research/hydropower>.
- Steimer, P K, O Senturk, S Aubert, and S Linder. 2014. “Converter-Fed Synchronous Machine for Pumped Hydro Storage Plants.” *2014 IEEE Energy Conversion Congress and Exposition (ECCE)*, 4561–67. <https://doi.org/10.1109/ECCE.2014.6954025>.
- Stouffer, K, V Pillitteri, S Lightman, M Abrams, and A Hahn. 2015. “Guide to Industrial Control Systems

- (ICS) Security.” Gaithersburg, MD. <https://doi.org/10.6028/NIST.SP.800-82r2>.
- US Army Corps of Engineers. 2019. “National Hydropower Program Strategic Plan FY2020 through FY2024.” <https://usace.contentdm.oclc.org/utis/getfile/collection/p16021coll11/id/4268>.
- US Bureau of Reclamation. 2011a. “Hydropower Resource Assessment at Existing Reclamation Facilities.” *United States Department of the Interior Bureau of Reclamation Power Resources Office*. Denver, CO.  
<https://www.usbr.gov/power/AssessmentReport/USBRHydroAssessmentFinalReportMarch2011.pdf>
- . 2011b. “Operation , Maintenance , and Field Test Procedures for Protective Relays and Associated Circuits.” Vol. 3–8. Denver, CO.
- . 2012. “Site Inventory and Hydropower Energy Assessment of Reclamation Owned Conduits.” Denver, CO.  
<https://www.usbr.gov/power/AssessmentReport/USBRHydroAssessmentFinalReportMarch2011.pdf>
- . 2017. “Science and Technology Program – Science Strategy – FY2018-FY2021.” [https://www.usbr.gov/research/st/docs/ST\\_Science\\_Strategy.pdf](https://www.usbr.gov/research/st/docs/ST_Science_Strategy.pdf).
- . 2021a. “Research Updates.” <https://www.usbr.gov/research/st/roadmaps/FY21RASPE.pdf>.
- . 2021b. “FY 2022 Science Strategy Annual Implementation Plan.” <https://www.usbr.gov/research/st/docs/SSIP22.pdf>.
- US Bureau of Reclamation, and US Army Corps of Engineers. 2017. *Dam Safety Risk Analysis Best Practices Training Manual*. Denver, CO; Washington D.C.  
<https://www.usbr.gov/ssle/damsafety/risk/methodology.html>.
- US Department of Energy. 2016. “Hydropower Vision: Full Report.” Washington, D.C.: EERE Publication and Product Library. <https://doi.org/10.2172/1502612>.
- . 2020a. “2019 Project Peer Review.” Washington D.C., (USA).  
<https://www.energy.gov/eere/water/2019-water-power-program-peer-review-report-and-presentations>.
- . 2020b. “Energy Storage Grand Challenge: Energy Storage Market Report.” Washington D.C., (USA). <https://energy.gov/energy-storage-grand-challenge/downloads/energy-storage->
- US House Energy and Water Development Committee. 2022. “ENERGY AND WATER DEVELOPMENT APPROPRIATIONS BILL, 2023.” Washington, D.C., USA.  
<https://www.congress.gov/117/crpt/hrpt394/CRPT-117hrpt394.pdf>.
- Vagnoni, E, A Favrel, L Andolfatto, and F Avellan. 2018. “Experimental Investigation of the Sloshing Motion of the Water Free Surface in the Draft Tube of a Francis Turbine Operating in Synchronous Condenser Mode.” *Experiments in Fluids* 59 (6): 95. <https://doi.org/10.1007/s00348-018-2552-x>.
- Verma, A K, S Ajit, and D R Karanki. 2016. *Reliability and Safety Engineering*. London: Springer.
- Wang, J, R Qu, Y Tang, Y Liu, B Zhang, J He, Z Zhu, H Fang, and L Su. 2016. “Design of a Superconducting Synchronous Generator With LTS Field Windings for 12 MW Offshore Direct-Drive Wind Turbines.” *IEEE Transactions on Industrial Electronics* 63 (3): 1618–28.  
<https://doi.org/10.1109/TIE.2015.2415758>.
- Witt, Adam M., B T Smith, A Tsakiris, T Papanicolaou, J L Pries, T A Burrell, K M Stewart, et al. 2017. “Exemplary Design Envelope Specification for Standard Modular Hydropower Technology.” Oak Ridge, TN (United States). <https://doi.org/10.2172/1343525>.

# APPENDIX A. OVERVIEW OF CURRENT HYDROPOWER TESTING

## A.1 Conventional Powertrain Testing

This section addresses the conventional testing the powertrain system intended as the combination of the hydraulic turbine and the generator. The electronics and interconnections that are related to the generators (and that could be categorized under powertrain, as well) are discussed in Section 2.4. The testing of hydraulic turbines is typically separated into model and field testing. Model testing has historically been integrated with the design process to characterize and optimize the performance of the turbine design. Field tests are used to verify that the characteristics of the prototype correspond to the specifics sold by the manufacturer (which results from model testing). Generators and electronics are conventionally tested in the field during and after installation. However, innovative generator designs are crucial for hydropower integration with new renewable energy resources and may benefit from new laboratory testing.

### A.1.1 Hydraulic turbine testing

#### *Turbine model testing*

Hydraulic turbine model testing has historically been a fundamental phase of turbine technology development and procurement for large hydropower machines. Essentially, the performance of a full-scale turbine (prototype) can be extrapolated from tests performed in laboratory settings on reduced-scale model turbines that are geometrically homologous to the prototype. This extrapolation is granted, in principle, by the laws of similitude, which define geometric, kinematic, and dynamic similarity—namely, the common ratio of corresponding dimensions, velocities, and forces, respectively. For instance, the specific speed is a dimensionless number derived from these relations and is typically used to classify hydraulic turbines. The detailed description of these theories can be found in most hydropower-related textbooks, such as *Hydropower Engineering Handbook* (Gulliver and Arndt 1991) and *The Guide to Hydropower Mechanical Design* (ASME Hydro Power Technical Committee 1996). Turbine manufacturers typically own private testing laboratories for machine design and development and to provide proof-of-performance to buyers. However, in some cases, independent labs have also provided testing services during large contract competitions.

The standard for conducting turbine model tests is IEC 60193, which specifies how to step up the performance results from model to prototype. IEC 60193 applies to laboratory models of any type of hydraulic turbine, including impulse, reaction, and pump-turbine. In terms of the testing dimensions defined in Section 1.4, this type of testing is partial scale, flow-through, component (turbine) testing with a mixture of steady-state and transient ambient conditions, and a mixture of static and dynamic response characterization. When tested according to the IEC standard, a turbine component of baseline powertrain technology is plumbed into a hydraulic test loop with high-accuracy flow metering and coupled to a dynamometer to enable collection of information regarding how well the turbine meets design objectives. Data that are obtained or verified through turbine model testing are summarized as follows:

- Turbine efficiency
- Turbine power
- Cavitation (area)
- Cavitation (vortex)
- Runaway speeds
- Pump-turbine four-quadrant characteristics
- Effect of shape changes on performance
- Draft tube effectiveness
- Performance/civil trade-off
- Whether the Winter-Kennedy taps for the turbine cycle and the draft tube taps for the pump cycle are at locations that give suitable results
- Loading and structural design

- Pump-turbine shut-off head
- Pump-turbine instability
- Pump-turbine cavitation effect on instability
- Pressure pulsation
- Air admission
- Optimal position of turbine components
- Pressure loading
- Axial thrust
- Radial thrust
- Wicket gate torque
- Blade torque (Kaplan turbine)
- Flow distributions
- Tool improvements
- Component losses
- Correlation with analytical design tool

These data are required to determine or validate the thresholds of operating conditions and design parameters at which abnormal or unstable conditions initiate, persist, or abate. Such information determines operating guidance, limits, and safety planning. These data are also used in the design of components to ensure that the strength, stiffness, and durability of materials, geometry, assemblies, and connections are selected to provide RRM under anticipated loads and duty cycles.

Standard model testing according to IEC 60193 does not address EI (Turbine environmental testing in Section 2.1.1.1) or direct assessment of reliability or durability. Additionally, it does not directly address the capability to provide services to power systems, although the information gained about hydromechanical efficiency does provide useful information about operating range (minimum and maximum power outputs) and effective use of water for generation.

This testing of codes and models is usually only justified for models of machines that, at full scale, have either a unit power greater than 5 MW or a reference diameter greater than 3 m. In other words, the size of the machine drives the need for incremental, partial-scale testing. For smaller machines, model testing is typically not economical since the machines may cost as much as the equipment being purchased. Larger machines are more likely to be expensive compared with scaled models, so partial scale testing may be worthwhile. In general, model testing is traditionally justified for the following reasons:

- To confirm the prototype rated performance, provided that the dimensional tolerance specified by IEC 60193 are respected
- If tests and measurements are performed in a controlled and qualified laboratory environment
- If relevant problems regarding transient phenomenon, cavitation, and pressure pulsation can be detected and consequent design adjustments can be implemented
- If a comprehensive range of operating conditions can be simulated
- To seek full optimization with fine-tuning only achievable through model testing
- To seek performance response to transient phenomena (e.g., flow increase/decrease, speed increase)

Although model tests are the best step to predict performance and characteristics of machine at full scale, several sources of energy loss cannot be scaled, or they follow different scaling laws, so perfect similitude can only be obtained by testing the prototype itself (or full-scale machines with the same dimensions). These losses are mainly related to leakages and friction. Several formulae, mostly based on the Reynolds number (i.e., the ratio between inertial and viscous forces of the fluid), have been proposed to account for this scaling issue and improve prototype efficiency. Manufacturers must choose how to present model test data, and the method must be specified to evaluate a true comparison with the prototype. These loss

conversion methods are typically specified in the IEC codes but mostly for reaction turbines only. For Pelton and other impulse turbines, scale effect methods to predict increased prototype efficiency may not be used.

### ***Full-scale turbine testing***

Model testing is used to evaluate the performance of a specific turbine design. The conversion of model testing results to the prototype is only valid if geometric similarity is respected, which still may be affected by several other factors that are characteristic of the full-scale configurations (e.g., non-scalable losses, approach flow conditions, effects of other adjacent operating units). Therefore, several field tests are typically performed to validate model data and assess the actual characteristics of the unit. Full-scale powertrain testing may require evaluation of conventional technologies such as generators, shafts, gearboxes, and turbines (e.g., vanes, gates, runners, blades); modular conventional integrated units (e.g., bulb turbines with integral components inside); new technologies (e.g., rim drive–integrated generators); and other technologies. Basic procedures are provided by ASME and IEC codes. Relevant test procedures are listed as follows.

- ASME PTC 18-2011 provides a performance test code for all sizes and types of hydraulic turbines and pump-turbines. Specifically, it defines methods to quantify the prototype’s efficiency by measuring flow rate (discharge), head, and power, and it includes requirements for pre-test arrangements, types of instrumentation, methods of measurement, testing procedures, methods of calculation, and the content of test reports.
- IEC TS 62882 is a technical specification that provides methods of pressure fluctuation transposition for Francis turbines and pump-turbines. The document describes the potential pressure fluctuation phenomena (e.g., inter-blade vortices, draft tube vortices rope and rotor-stator interaction), how to measure and analyze them at model and prototype scales, and methodologies to transpose the results from model to prototype.
- IEEE 810-2015 provides a standard for hydraulic turbine and generator shaft couplings (both horizontal and vertical) and shaft runout tolerances.

### ***Turbine environmental testing***

Unlike basic mechanical and electrical tests, environmental testing for hydraulic turbines has no published standards across the industry. Most of the tests are performed in late stages of development, as required by regulators during the licensing process. However, examples of turbines designed to improve the environmental footprint of hydropower exist, along with some basic tests. Most of the environmental enhancements are typically introduced in the runner of a turbine and address fish passage survivability and water quality (e.g., dissolved oxygen levels, toxicity, lubricant leakage).

For many years, DOE, EPRI, and the Hydropower Research Institute have supported the R&D of fish-friendly turbines to minimize the injury and mortality of fish, maintain adequate level of water quality downstream of the plant, and have a high energy conversion efficiency. The two most notable turbines design developed are the Alden turbine<sup>61</sup> and the Voith Minimum Gap Runner<sup>76</sup> (Cook et al. 2000; Hogan, Cada, and Amaral 2014). More information regarding the fish-friendly turbine developed and tested by Alden and Voith is available in the technical reports published by EPRI and DOE (Cook et al. 2000; Electric Power Research Institute 2007a; 2007b; 2008; 2011; Electric Power Research Institute and US Department of Energy 2011; Foust et al. 2011). The test facility developed by Alden to test the

---

<sup>76</sup> <https://voith.com/corp-en/products-services/hydropower-components/turbines.html>

turbine design was a 0.9 m wide and 16.5 m long tank, with a 1.2 m square opening at the top to place fish in the test section and visually record the blade strike using high speed cameras. Blade models were mounted on a cart that could be propelled toward the fish by a cable system, with variable speed capability.

USACE has also conducted several tests to improve the knowledge of the turbine passage environment and its impact on fish for fish-friendly turbines through the Turbine Survival Program. Physical models were developed at the USACE ERDC<sup>66</sup> (Section 4.1.4) to study the streamlines created by the passage of dye and small, neutrally buoyant beads through turbine runners (Electric Power Research Institute and US Department of Energy 2011).

Recently, Natel Energy introduced the Restoration Hydro Turbine,<sup>23</sup> a compact hydraulic turbine designed to be safe for fish owing to its innovative compact runner and thick blades facilitating a curved and slanted leading edge. The design was tested at Alden Research Laboratory, where blade strike tests were performed using an additively manufactured version of the same design in the same facility used to test the Alden turbine. These tests showed that the Restoration Hydro Turbine design can enable >99% safe passage of salmonids (Amaral et al. 2020).

In general, fish-friendly turbines are tested using physical testing of scaled turbine models or computational fluid dynamics simulations to visualize the flow through the runner. Actual fish survivability experiments are done on prototype-scale turbines in lab or field testing. The industry-standard method to evaluate injury and survival is to release balloon-tagged fish through the turbine unit and recapture the fish downstream of the dam (Hogan, Cada, and Amaral 2014). To ensure the accuracy of the survival test while accounting for neutral buoyancy during release, delayed balloon inflation techniques were introduced to capture the fish after the turbine passage. Recently, new methods were introduced to mimic fish passage using telemetry and other sensors to track the path through the powertrain system and quantify the physical stressors that fish might experience. One of these instruments is the Sensor Fish<sup>77</sup> designed by PNNL, which includes several sensors that measure acceleration, rotational velocities, orientation, pressure, and temperature at 2,000 Hz and can store up to 5 min of data. This inertial tubular device is released in the water and flows through the hydraulic turbine (Deng et al. 2007; 2010). Another example is the fish surrogate created at ORNL from a collaboration between the Aquatic Ecology Laboratory and the Manufacturing Demonstration Facility to measure the actual force experienced by a fish stroke by a turbine blade without harming live fish. A prototype biomimetic model fish composed of ballistic gelatin and covered with a surrogate skin to better approximate the biomechanical properties of a fish body was developed at ORNL and equipped with a 3-axis accelerometer (Saylor et al. 2021; Saylor 2021).

Pflugrath et al. (2020) provided an excellent reference that summarizes the potential consequences of fish passing through the powertrain section of a dam. The report was funded by WPTO through the HydroPASSAGE project with the goal of providing tools to the hydropower community to evaluate and mitigate the impacts of dam passage on fish. This report by Pflugrath et al. (2020) developed and collected 99 biological response models from the literature for exposure to specific stressors that are typical of passage through hydropower turbines to predict injury or mortality. These stressors correspond to specific tests that different fish species (31 included in the report) are subjected to and are summarized as follows:

- *Blade strike (collision)*: when fish collide against part of the structure such as stay vanes, wicket gates, screens, and, mostly, turbine blades. In these tests, an anesthetized fish in a tank is struck by a model version of a blade. Tests analyze different blade thicknesses, blade velocities, and angles of

---

<sup>77</sup> <https://www.pnnl.gov/available-technologies/sensor-fish-mini>

impact. Results have shown that the ratio of fish length to blade thickness is an important factor, with survival rates increasing as the ratio decreases. In general, thicker and slower runners are less likely to cause injuries.

- *Rapid decompression*: when fish experience a rapid (<1 s) change in pressure that can cause body damage (i.e., barotrauma). Fish are placed in chambers where pressure can be changed between above and below atmospheric level to simulate the passage within the turbine unit. Fish are then inspected to assess injuries and mortality. Results have shown that the greater the ratio of decompression, the greater the body damage, which typically relates to the expansion of gas within the swim bladder (buoyancy-regulating organ of fish) when a fish is decompressed.
- *Fluid shear*: when fish are exposed to a mass of water moving in a different direction and/or at different velocities. Tests are conducted to expose fish to underwater jets at different jet velocities and then assess injuries and mortality rates. In general, fish are more susceptible to injury or mortality as strain rate or acceleration increases.

In all the three types of tests, different species responded differently within the same test type and to different stressors (i.e., a species' susceptibility to one stressor does not necessarily indicate similar susceptibility to another stressor). These types of tests will need to be extended to additional species with different morphological traits and different behaviors, and to explore additional environmental and physical variables (e.g., temperature, swimming activities, multiple exposures).

The biological response models developed were ultimately integrated into two software tools: the Biological Performance Assessment toolset and Hydropower Biological Evaluation Toolset. Both tools quantify the magnitude of the stressors that the fish may experience and, in combination with the biological response models, estimate the probability of injury or mortality. The former uses computational fluid dynamics, and the latter uses the Sensor Fish described previously.

### **A.1.2 Generator testing**

The generator is a key component of hydropower powertrain systems and must undergo rigorous testing. The most used types of generators are synchronous and induction. Historically, synchronous machines have been used as the electrical generator in conventional hydropower plants. Pumped storage facilities can deploy synchronous motor-generators, sometimes with a frequency convertor, or asynchronous motor-generators to perform as a generator for electricity production, or as a motor (by reversing the same unit) to pump water from the lower basin to an elevated reservoir for future electricity generation.

For hydropower facilities that use synchronous generators, IEEE 115 is a guide for testing synchronous machines and generators. It outlines tests that can be used to analyze performance, safety, and other factors; however, it does not directly recommend which tests to conduct, so hydropower developers must refer to other standards for recommended tests. IEEE C50.12-2005 (R2010) references IEEE 115 and other IEEE standards to outline specific tests required for all types of 50 and 60 Hz salient-pole synchronous generators and generator/motors rated 5 MVA and above to be used for hydraulic turbine or hydraulic pump/turbine applications. Generators below this rating are generally covered by NEMA MG 1-2003. The required and recommended tests for synchronous generators are summarized as follows:

- Mechanical balance
- Voltage balance
- Phase sequence
- Insulation resistance of stator and rotor windings
- Overspeed
- Heat runs
- Dielectric tests for stator and rotor windings
- Open and short circuit saturation curves



IEC 60034-2 and IEC 60034-4 provide additional performance testing for AC generators.

For hydropower facilities that use induction generators, IEEE 112 provides standard test procedures for induction for polyphase induction motors and generators. The tests include typical tests, preliminary tests, idle running, tests with loads, and tests with rotor locked. For typical tests, IEEE 112 refer to NEMA MG parts 12 and 20. Preliminary tests focus on gathering specifications such as winding resistance and ambient temperature (as measured in IEEE 119). The other tests focus on stressing the generator under different operating conditions, which include running idle, without a load, and with the rotor locked. The required and recommended tests for induction generators are summarized as follows:

- Efficiency
- Stator losses
- Rotor losses
- Core losses
- Rotor voltage
- Speed torque characteristic
- Power factor
- High potential
- Temperature
- Vibration
- Rotor balance
- Insulation resistance

IEEE 112 does not disclose any specific environmental requirements.

## A.2 Conventional Conveyance Testing

Historically, most conveyance systems, and specifically their hydraulic performance, have been tested through physical modeling. With increasing computational power, numerical modeling is also used for design refinement, performance testing, and flow visualization when complex structures are involved, or when the problem scale is too large to be scaled down to a physical model. However, boundary conditions and numerical results still require validation through model testing.

Most of the water conveyance structures of a hydropower facility have used physical modeling in the past and are still good candidates for laboratory hydraulic studies. For instance, spillway models are used to investigate the dissipation performance and air entrainment of stilling basins, flow hydrodynamics, pressure distribution, and potential erosion over and downstream of the structure. Intakes are modeled to visualize the flow transition and the possibility of vortex formation, study resonance frequencies in fluid-structure interaction, and ultimately prevent head losses. In general, conveyances are a product of structural and hydraulic engineering, and model studies are used to verify design functionalities and structural safety while potentially reducing estimated construction costs and minimizing unexpected expenses. Post-construction solutions to hydraulic issues could be very expensive, and perhaps even cost-prohibitive for project success.

Physical models of hydraulic structures are typically designed based on the available space of the facility, the type of measurements, flow requirements, and scale effects. The engineers and technicians of the testing laboratory design and build the scaled model based on the drawings provided by the project owner and the boundary conditions. Scale effects are one of the most important factors to consider during design and testing. Typically, models are designed to maintain constant ratios of forces and geometry between full and partial scales. However, maintaining consistency for all the parameters at once can be challenging; thus, the most crucial parameters for testing are identified, and others could be neglected because they will not alter the results. Inertial forces (related to the velocity of the flow), gravity, pressure forces, surface tension, and viscous forces are some of the most significant forces involved in hydraulic model studies. The combination of these creates nondimensional parameters that typically dictate the similarity constraints between model and full scale, such as the Froude number ( $Fr$ , the ratio between

inertial forces and gravity, particularly important for free-surface flows), the Reynolds number ( $Re$ , the ratio between inertial forces and viscous forces), or simply the geometric ratio for particle sizes. Another important parameter in environmental flows and mass transport phenomena is the Schmidt number (the ratio between momentum and mass diffusivity). The Froude number is typically an important parameter to match in hydraulic modeling and allows the determination of the flow rate and velocity once the ratio of the physical dimensions is decided as follows:

$$Fr = \frac{V_m}{\sqrt{gL_m}} = \frac{V_f}{\sqrt{gL_f}} \Rightarrow \frac{V_m}{V_f} = \sqrt{\frac{L_m}{L_f}} \quad (1)$$

where  $V$  is the flow velocity,  $m$  is the model scale,  $f$  is the full scale,  $g$  is gravity, and  $L$  is the characteristic physical dimension of the problem.

### A.2.1 Measurement techniques and types of testing

Typical measurements techniques for hydraulic conveyance involve the following:

- *Flow rate measurements*: quantification of the flow discharge through the conveyance structure. For hydraulic testing, the discharge is typically a boundary condition set a priori (before it enters the testing volume). Typical instruments to measure the flow rate are the Venturi meter (measure of the pressure drop in a restricted section of a pipe), propeller meters, electromagnetic and ultrasonic meters, and the empirical estimation through the observation of the flow over a weir.
- *Flow velocity measurements*: evaluation of the water velocity moving through the testing volume, typically in a single point in space. Single-point measurements are usually acoustic (e.g., acoustic Doppler velocimeter) or laser-based (e.g., laser Doppler velocimeter). These instruments can resolve the three components of velocity and the turbulent intensities at a point in space. The acoustic Doppler current profiler is also based on the Doppler effect of acoustic signal but allows for measurement of flow and turbulence at different locations along the water depth vertical profile. Both techniques require the instrument to be in the flow. The laser Doppler velocimeter harnesses the Doppler effect of laser sources and it is completely nonintrusive but requires an optical access to the flow volume. Another single-point instrument is the Pitot tube, which estimates the flow velocity by measuring the differential between the static and dynamic pressure at a point. Newer techniques can also measure the 2D and 3D flow field. Bi- and tridimensional flow measurements are mostly known as particle image velocimetry and allow to map the average and turbulent flow field by recording the movement of naturally buoyant particles passing through a laser-illuminated plane using high-speed, high-resolution cameras.
- *Flow visualizations*: all the techniques that allow visualization of the flow field, even on a qualitative basis. Particle image velocimetry systems are sophisticated flow visualization techniques that also allow for the quantification of average velocity and turbulence but are typically expensive and limited to a relatively small visualization window. Recently, particle image velocimetry techniques were extended to large fields of view to evaluate the atmospheric flow field using snowflakes as tracking particles. Simpler techniques involve the use of dye injection and simply tracking floating particle on the surface. For instance, Lindblom and Gulliver (1983) used a Froude scale model to study the flow approaching the intakes of a retrofitted hydropower plant. Severe vortices were visualized using confetti as tracers and improved design solutions were suggested.
- *Pressure measurements*: achieved through pressure transducers and probes. In hydraulic testing, monitoring static and dynamic pressure is important. Pressure distribution, fluctuations, and gradients

are usually monitored to evaluate the performance, resistance, and resilience of the conveyance material on the surface or deep in the structure.

Conveyances are conventionally tested for hydrodynamic performance and structural reliability. Flow is monitored to evaluate whether the structure is performing as designed, improve flow conditions, and minimize potentially harmful turbulent structures. For instance, strong vortices at the inlet could be detrimental for turbine operations. Design adjustments such as smoother transitions, rounder edges, or antivortex plates are introduced to minimize the formation of vortices and improve the conveyance performance and generation production (Lindblom and Gulliver 1983). Velocities and water quality are typically monitored in stilling basins to evaluate the dissipation efficacy and the air entrainment at the bottom of spillways. Pressure fluctuations on the surface of spillways, gates, and other structures where fast flows occur are measured to monitor vibrations and the potential formation of cavitation and erosion (Peng et al. 2018). Pressure fluctuations and propagation are also measured frequently in penstocks because they are prone to failure caused by pressure shockwaves (Cai et al. 2017). Load rejection experienced at the generator can cause a large pressure wave (i.e., waterhammer) that may induce tensile stresses and the ultimate failure of the penstock. Alternatively, a sudden closure or obstruction of the upstream intake can cause vacuum in the penstock and lead to its buckling. Most of these effects are related to transient operations and thus require testing infrastructure that can reproduce transient conditions.

### **A.3 Conventional Structural and Geotechnical Testing**

Testing of structural technologies imparts several key challenges. The first challenge is to identify the composition and structure of the underlying substrate, which requires geotechnical site assessment capabilities that explore and characterize the subsurface in a safe and cost-effective manner. The second challenge, once the site characteristics and desired superstructure are determined, is to assess potential failure modes and design the superstructure-foundation system accordingly. This requires materials and subsurface treatment in addition to structural component construction and installation. The third challenge is to monitor and maintain these technologies for the life of the project. Each challenge requires the use of structural technologies whose design objectives must be validated through testing.

As described by DeNeale et al. (2020), “the way in which the foundation interface is designed and constructed depends on characteristics of both the superstructure and the subsurface . . . with engineering and environmental characteristics . . . as well as technoeconomic considerations . . . influencing the development process.” As a starting point, geotechnical site assessment is conducted to determine the site-specific subsurface characteristics, thereby informing the hydropower facility’s design and construction. Details of the site characterization, foundation design, and overall project design are further refined through an iterative process of information gathering during the three main development phases of hydropower foundation engineering: geotechnical site assessment, foundation design, and foundation construction. Geotechnical site assessment is informed through the use of remote, field (in situ), or laboratory testing methods, as described hereafter. These testing methods rely upon the use of geotechnical sensing methods and equipment. Successful foundation design and construction requires knowledge of the available subsurface and geologic characteristics, as well as design specifications for the proposed superstructure. Hydropower superstructures primarily include dams, powerhouses, and spillways. Proper engineering design of each of these systems requires knowledge of how the anticipated hydraulic conditions impart forces (i.e., loads) on the physical structure and how the foundation system design alleviates any forces. Following traditional dam safety risk assessment, this engineering design

involves conducting potential failure modes analysis<sup>78</sup> to assess how a dam may fail (Federal Energy Regulatory Commission 2017; US Bureau of Reclamation and US Army Corps of Engineers 2017). As described by DeNeale et al. (2019), potential failure mechanisms include overtopping, internal erosion, sliding, overturning, overstressing, spillway failure, and other mechanisms. Ensuring that the superstructure and foundation systems are designed to operate safely and reliably requires testing the ability of the system or components to impound water while reducing or eliminating seepage and maintaining structural stability and support. This testing can involve field or laboratory testing of concrete and structural components, and materials and corrosion properties. Similar concrete, structural, materials, and corrosion testing may also be required for powerhouses to ensure safe and reliable equipment housing is maintained.

Validating a structural technology's ability to meet its design objectives requires implementing various measurement and testing methods. These can be broadly categorized as remote, field, or laboratory testing methods to support geotechnical site assessment or structural testing. Geotechnical site assessment often starts with desktop (remote) assessment using available and collected information, such as topographic, geologic, and agricultural maps and aerial imagery. Additional site reconnaissance, including the use of remote sensing technologies, can be conducted to better assess foundation conditions prior to more thorough field and laboratory studies.

Once a site has been preliminarily investigated to rule out any features that may prove fatal to the overall project's success, more detailed field testing is conducted. Common field testing typically includes subsurface investigation, geophysical exploration subsurface exploration, in situ testing, pore pressure evaluation, and permeability testing, as described in more detail by DeNeale et al. (2020). These measurements and tests are conducted to better assess the site-specific foundation condition and begin quantifying some of the physical characteristics of the subsurface prior to foundation treatment.

Obtaining more detailed information on the subsurface soil and rock characterization involves laboratory testing. Soil laboratory testing is commonly conducted to determine soil properties such as moisture content and density, specific gravity, Atterberg limits, particle size distributions, corrosivity, permeability, consolidation, swell/collapse potential, shear strength, and compaction. Rock laboratory testing is commonly conducted to determine shear strength and compressibility characteristics. Additional information on soil and rock characteristics and laboratory testing methods can be found elsewhere (DeNeale et al. 2020).

In addition to geotechnical measurement and testing, which involves assessing the natural subsurface conditions and characteristics, structural testing is also needed to validate the ability of manufactured structures to meet design objectives. This conventionally involves field or laboratory testing of concrete and structural components, and materials and corrosion properties. ASTM International develops concrete testing standards.<sup>79</sup>

#### **A.4 Conventional Electrical Interconnection Testing**

Traditional hydroelectric facilities use rotating generators (synchronous or induction) to convert mechanical energy to electrical energy as opposed to power electronic converters (inverters), which are only now emerging in use for hydroelectric generator interconnection. Historically, these facilities are

---

<sup>78</sup> The Federal Energy Regulatory Commission (2017) defines potential failure modes analysis as “an exercise to identify all potential failure modes under static loading, normal operating water level, flood and earthquake conditions including all external loading conditions for water retaining structures and to assess those potential failure modes of enough significance to warrant continued awareness and attention to visual observation, monitoring and remediation as appropriate.”

<sup>79</sup> <https://www.astm.org/Standards/cement-and-concrete-standards.html>

connected to the transmission or distribution system of a local or federally owned utility company. With synchronous or induction generators, the hydropower developer and utility company formulate an interconnection agreement. The agreement sets out the testing requirements that must be met to connect to the utility company's power grid. These interconnection agreements are based on NERC standards such as NERC FAC-001, which are aimed at helping maintain the reliability and stability of the grid. The requirements include voltage, power factor, frequency, grounding, protection, and other electrical requirements. Induction generators testing is less complex than synchronous generators because induction generators' frequency and other parameters are set by the power grid. Appendix A.1.2 summarizes additional generator testing.

#### **A.4.1 Modern measurement and testing methods**

Because traditional hydroelectric facilities are large, conventional physical electrical interconnection testing of hydroelectric power plants is typically performed on-site at commissioning. Before this testing, power system simulation software, both steady-state and transient, is used to model and simulate the impact of the generator on the local and greater power system before commissioning, and this process is referred to as a *system impact study*.

The safe, reliable operation of the electrical power grid requires a method of modeling and calculation or computation of the available short circuit current contributions from hydropower generating facilities over a variety of operating conditions and constraints affecting both prime mover output and connected load. To provide appropriate engineering design of the grid and interconnection with hydropower generation, the proper rated duties of electrical power delivery equipment and associated switchgear or circuit breakers are based on the known available short circuit current capabilities. These decisions from the engineering design will also dictate the selection and coordination of protective relays and devices for isolation of faults and normal switching operations.

#### **A.4.2 Simulation and analysis of conventional hydroelectric interconnections**

Steady-state analysis focuses on the stable behavior of the power system and can determine the facility's impact on voltage during worst-case scenarios using load flow analysis and steady-state fault current using short-circuit analysis. Transient dynamic simulation is much more detailed than steady-state and can determine the facility's impact on transient fault current, transient frequency stability, and transient rapid voltage change. Standard dynamic models of rotating generators include Types I, II, III, IV, and V as described in Section 2.1.2.2.

Other studies include reactive power studies and harmonic studies. Reactive power studies estimate the capability of the facility to provide reactive power support to the grid during various output and interconnection voltage limits. These are typically performed in steady-state load flow power system analysis programs, but transient simulation may be used to measure reactive power support during faults or other system events. Harmonics analysis studies include the study of the interaction of harmonics generated from the grid and harmonics generated from the facility under study, which can be provided by the manufacturer. Because the harmonic behavior of the grid is typically not known, most harmonics studies are preliminary in nature and are performed with many assumptions. Furthermore, the actual harmonic behavior can only be confirmed once a power quality meter is installed at the point of common coupling, which will collect real-time harmonic data.

### **A.4.3 Commissioning and physical testing of conventional hydroelectric interconnections**

The commissioning and physical testing of hydroelectric power plants follows the IEEE 1248 standard, which separates the testing into the construction testing phase, preoperational testing phase, operation testing phase, and performance testing phase.

The construction testing phase includes required tests to demonstrate that completed installations are in accordance with the latest engineering and design information. Specific testing related to the electrical interconnection includes the following:

- Insulation resistance, partial discharge, and high potential testing of electrical equipment and cables
- Continuity testing to verify cable routing
- Initial operation of motors uncoupled (phase rotation check)
- Inspection and testing of electrical equipment (e.g., transformers, motor control centers, switchgear)
- Insulation resistance testing of electrical equipment, to be done prior to terminations (power cables)
- Verification of cable terminations in accordance with design documents
- Equipment grounding verification
- Testing to verify plant communications system and networks

The preoperational testing phase includes the testing required for system components before energizing or operating the major system component. Specific testing related to the electrical interconnection includes the following:

- Final checkout of electric motors
- Checkout and verification of electrical control circuitry and software through functional testing
- Calibration of electrical relays and meters
- Checkout and trip check testing of switchgears, motor control centers, and molded case breakers

The operational testing phase includes the testing required to verify system operation in accordance with the design requirements after the major components are energized or operated. Operational testing of electrical systems includes breaker testing, protection/coordination testing, operating temperature (for electrical devices), and power quality. Power quality testing is important because power system transients such as voltage or current abnormalities can damage electrical interconnection equipment, which can cause affect the performance and reliability of the generation plant.

The performance testing phase includes the testing conducted to evaluate the compliance of a system or component with specified performance. Specific testing includes the following:

- Testing of unit and generator efficiency
- Testing of power-gate relationship
- Performance runs at prescribed loads
- Testing to develop and validate the system electrical models
- Testing of generator temperature rise

### **A.5 Conventional I&C Testing**

Fundamental I&C tests need to be completed before a hydropower plant can be safely operated and controlled. IEEE 1010, 1827, and 1248 guide I&C testing. Common I&C systems that require testing include the governor control system, the protection system, the generator excitation control system, and communication systems. Outside of the conventional electromechanical control systems, environmental

sensors and monitoring technologies are also important to understanding the interactions of plant operation with the local ecosystem. Once the individual systems are tested, the entire facility can be tested prior to final commissioning to ensure that the different control systems and instrumentation function correctly together.

### A.5.1 Governor system

In traditional hydroelectric power plants, the governor control system is the main controller of the hydraulic turbine and uses data from sensors and instruments to maintain proper control of the generator. One of the major factors that needs to be controlled is the generator speed and load demand balancing. To vary the speed of the generator, the governor of a hydropower facility varies water flow. Ultimately, the speed and load of the generator affects the system frequency. Testing needs to be completed to verify that the governor responds to changes in load or other events with the appropriate behavior. Instrumentation such as the physical sensors, actuators, and servomotors need to be tested to ensure that they function properly. Conventionally, all the controls for these tests would be operated by sending signals through hardwired connections from a central physical control board. This setup comes with limitations that can be overcome with modern control systems using digital control techniques and using computer graphical interfaces. Modern digital control and automation systems are being used in hydropower systems for remote operation and improving flexibility by being able to easily switch control schemes. IEC 61362 provides additional information on the control, performance, and modeling.

With the governor system's main purpose of controlling the water flow of the turbine, running several tests on each component within the governor system is important. IEEE 1207 and 125 provide information on testing governor systems. Specifically, IEEE 1207 focuses on "performance characteristics and equipment specifications to turbine governing systems for hydroelectric units." The standard describes tests that be completed for factory acceptance testing and field acceptance testing. Tests that can be completed for each type of acceptance test are listed as follows.

Factory acceptance testing:

- *Deadband testing* verifies that a turbine governor system meets the speed deadband requirements from ASME PTC29 or IEC 60308.
- *Deadtime testing* verifies that a turbine governor system can respond to a frequency change within a specified deadtime as described in ASME PTC29 or IEC 60308.
- *Gain verification testing* verifies that the compensating gains of the governor system match the response of the governor equipment.
- *Transient immunity testing* verifies that governor system will continue to work in the "presence of electromagnetic interference experienced in the field."

Field acceptance testing:

- *Servomotor timing testing* verifies the rate of travel as described in ASME PTC29 or IEC 60308.
- *Upset stability testing* studies the system's capability to return to rated speed after being disrupted.
- *Load rejection response testing* studies the governor system's ability to return to stable speed control and pressure rise after a load rejection.

- *Online generation response testing* studies the behavior of the governor system to a “setpoint change when synchronized to the interconnected power system.”
- *Online servomotor response testing* studies the behavior of the servomotor to a “setpoint change when synchronized to the interconnected power system.”
- *Deadtime testing* verifies that a turbine governor system can respond to a frequency change using the infield turbine control servomotors within a specified deadtime as described in ASME PTC29 or IEC 60308.
- *Speed stability index testing* verifies the speed stability index as described in IEEE 125.
- *Power stability testing* verifies the power stability index as described in IEEE 125.
- *Simulated speed step testing* studies the gate position response when a stimulated step in speed is applied.

In addition to the tests provided by IEEE, NERC provides reliability tests in *Reliability Guideline Power Plant Model Verification and Testing for Synchronous Machines*. These tests analyze the behavior of the governor system in different scenarios. Some of the tests include the following:

- *Power-gate testing (hydropower units)* studies the relationship of gate position vs. active power.
- *Blade-gate testing (hydropower units)* studies the relationship of blade position vs. active power.
- *Speed/frequency or megawatt load reference step testing* studies the governor system’s response to changes in speed/frequency or the plant controller’s response to megawatt changes.
- *Frequency sweep testing (hydropower units)* studies the behavior of available signals (e.g., power output) in the system once an oscillation is injected into the system.
- *Closed-loop testing emulating islanded mode of operation* studies the governor response to a simulated error showing an “imbalance between the mechanical torque and electrical torque.”

ASME’s *PTC-29 Speed-Governing Systems for Hydraulic Turbine-Generator Units* provides additional testing for electronic and mechanical governor systems for performance and operational functionality.

### **A.5.2 Protection systems**

The protection system in a hydropower plant ensures that the equipment and personnel are protected from electrical or physical disturbances, such as faults, transient overvoltage, and extreme temperatures. Testing the protection system includes verifying that devices and instrumentation are operating properly and responding within an acceptable time frame. When a relay measures a value over or under a threshold for a specified length of time, it sends a signal to breakers to operate to prevent damage to system equipment or injury to personnel. USBR’s *Operation, Maintenance, and Field Test Procedures for Protective Relays and Associated Circuits Volumes 3–8* (US Bureau of Reclamation 2011b) provide the modern electrical protection measurement and testing methods for hydropower facilities.

Modern electrical protection systems use microprocessor relays, which have mostly replaced electromechanical relays. Both types of relays perform similar basic protection functions; however, microprocessor relays can perform the functions of multiple electromechanical relays and also provide



better control, flexibility, and logic programming. Modern protective relay types are listed as follows. These relays should be tested for calibration and functionality during commissioning, regular intervals after commissioning, and after settings changes. Specific relay testing include functional testing of relays and circuits, functional testing between relay outputs and breaker input, and lockout relay timing.

- Distance relays
- Directional and nondirectional ground relays
- Directional and nondirectional overcurrent relays
- Transformer differential relays
- Bus differential relays
- Phase balance relays
- Breaker failure relays
- Auxiliary tripping relays
- Transfer tripping relays
- Loss of field relays
- Stator ground relays
- Reverse power relays
- Volts-per-hertz relays
- Negative sequence overcurrent relays
- Generator differential relays
- Frequency relays
- Out-of-step relays
- Breaker failure relays
- Other miscellaneous relays (e.g., temperature, pressure, fire)

The instrumentation of modern electrical protection systems mainly revolves around measuring current and voltage with instrument transformers, which comprise current transformers, potential transformers, and coupling capacitor voltage transformers. Other instrumentation can include equipment such as temperature and pressure sensors. Modern protection system instrument transformer testing includes the following:

- *Ratio measurement:* Current, potential, and coupling capacitor voltage transformers reduce current and voltage to levels suitable for protective relays and other control system devices. The ratio between the actual circuit value and the reduced value for current and voltage requires testing for accuracy during commissioning. These tests are typically performed by comparing the instrument transformer being tested to another instrument transformer with a known ratio.
- *Burden measurement:* Instrument transformers typically provide signals to multiple devices, including relays, meters, alarms, indicating lights, transducers, and other input modules. Each of these devices adds an impedance burden to the instrument transformer as they are added in series (current transformers) or parallel (parallel transformers) to the secondary circuit. If the capacity of the instrument transformer is exceeded, the instrument transformer cannot accurately measure current or voltage, which may cause a relay to misoperate or not operate. Therefore, the burden of instrument transformers must be verified during commissioning and at regular intervals. This is less of an issue when using microprocessor relays compared with electromechanical relays.
- *Output signal verification:* Instrument transformers must have their output signals verified to ensure the relays and other control devices are receiving accurate and consistent measurements. Inaccurate measurements could cause relays to misoperate or not operate at all, and therefore, the instrument transformer output signal should be tested upon commissioning and at regular intervals.
- *Current transformer internal resistance measurement:* The internal winding resistance of current transformers must be measured to ensure the condition and accuracy of the current transformer. The winding resistance can be found by dividing the voltage drop across the winding by the applied DC current through the winding. This testing should be performed during commissioning and at regular intervals since this value can change as the current transformer ages.

- *Current transformer excitation testing:* The excitation current of a current transformer must be measured and compared against previously measured values or manufacturer data during commissioning and at regular intervals. To measure the excitation current, the current transformer must be demagnetized, and a high voltage AC current test source must be connected to the secondary. This input voltage source is varied, and the current drawn by the winding is measured at each value of voltage. Any deviations from historical measurements should be investigated because they could indicate an internal short, distortion of the supply voltage, or presence of a completed conduction path around the core.
- *Secondary circuit polarity, phasing, and connection testing:* The primary and secondary instrument transformer connections (delta or wye) should be verified during commissioning and at regular intervals. Incorrect polarity or phasing connections will affect the measurements of current and voltage by the relays, which could cause improper operation.
- *Secondary grounding testing:* Current and potential transformer secondary circuits should only be grounded at a single point, and these circuits should be tested to verify this ground during commissioning and at regular intervals. Wiring modifications, insulation deterioration, relay replacement, and other changes can comprise this ground, which could cause relays to misoperate or fail to operate. Furthermore, secondary circuit grounding issues could affect other tests.
- *Insulation resistance testing:* The insulation resistance of instrument transformers must be measured during commissioning, after modifications to the relay system, and at regular intervals. Resistance values should be greater than 1 M $\Omega$ , and insulation with resistance values lower than this threshold may be damaged. IEEE C57.13 provides more information regarding standard testing for current and potential transformers.

### **A.5.3 Generator excitation system**

The generator excitation control system maintains the reactive power and transient capabilities of synchronous hydroelectric generators. This generator control component is responsible for automatically regulating voltage at the generator terminals by controlling the reactive power output of the generator. Additionally, the excitation system of a generator may be connected to a system-wide control system with multiple synchronous generators for system-wide automatic voltage regulation. IEEE 421.2-2014 provides objectives for testing of excitation control systems. Specific testing of the excitation control system for dynamic performance includes large-signal performance testing, fault testing, and small-signal performance testing.

IEEE 421.3-1997 provides the requirements for high-potential dielectric testing of complete excitation systems for synchronous machines. High-potential tests verify the ability of the insulation of the excitation-system components to withstand voltage stresses imposed during normal or transient conditions (e.g., faults, asynchronous operation, other unusual operation).

NERC's *Reliability Guideline Power Plant Model Verification and Testing for Synchronous Machines* provides guidance related to testing and simulation model verification for synchronous generators. Specifically, it provides the testing guidelines for the generator's reactive power and voltage regulation capabilities, which are directly related to the excitation system because this is responsible for providing the reactive capability for voltage support. This testing ultimately provides the reactive power capability as it relates to voltage and active power output, and the parameters of these can then be used for modeling and simulation purposes. Specific testing related to the generator excitation system includes the following:

- *Open-circuit magnetization (saturation) testing* is conducted with the machine operating at full speed and no load with the generator main breaker open (not connected to the grid). Typically, in this test, the field current starts at a low value, and the field current and generator terminal voltage are increased to determine the saturation characteristics. Field voltage and field winding temperature measurements are also recommended to be recorded during this test.
- *V-curve testing* should be performed at various different loading levels (0% load, partial load, and >90% load). For this test, the machine starts at unity power factor and then is slowly incremented to the leading (under-excited) operating limit and then to the lagging (over-excited) operating limit. Incremental measurements of megawatt, megavolt ampere of reactive power, kilovolt, field voltage, and field current are recorded. This test is used to estimate several generator parameters for modeling and simulation.
- *Exciter step testing (i.e., voltage reference step testing)* verifies the automatic voltage regulation models and parameters by stepping the reference voltage during several operating conditions.
- *Volts per hertz limiter, over-excitation limiter, and under-excitation limiter testing* is performed during automatic voltage regulation commissioning, following changes in automatic voltage regulation settings, or during excitation system upgrades. The testing verifies a stable response of the limiter action and determines when it will and will not operate, which confirms its coordination with protective relays. USBR's REC9102 also provides information and testing related to synchronous generator excitation systems.

#### **A.5.4 Communication systems and metering**

The modern hydropower system can be controlled from a single remote location using SCADA control schemes with wireless communication and distributed computer systems. The computer resources and control systems used depend on the size of the hydroelectric system. The main control systems in the plant include control for the turbine speed control, excitation systems, plant mode operations, and data collection. Communication testing for hydropower control systems includes testing for connections, latency (data transfer speed) testing, and testing for functionality in sending and receiving data between devices.

Instrument transformer testing for metering follows a similar testing approach as the instrument transformer testing for protection systems; however, the instrument testing for metering has more stringent accuracy requirements. These measurements are typically tied to customer billing and therefore must be accurate, whereas protection system instrumentation only requires approximate measurements because it relies on thresholds for high fault currents. Because of the decreased fault current introduced by inverter-based generation, lower rated, more accurate instrumentation may be required in future protection systems.

#### **A.5.5 Environmental monitoring instrumentation**

Instrumentation for monitoring the environmental conditions is important for meeting license requirements and assessing the performance of environmental technologies. Common areas of environmental instrumentation include monitoring upstream fish passage, turbine mortality, turbine aeration, sediment transport, and water quality. Best practices for environmental monitoring in specific environments may be available from federal, state, or local resource agencies, but hydropower industry-wide standards for environmental performance are not widely available. In addition to accurately monitoring the subject of study, environmental monitoring instrumentation must have negligible impact on the subject of study. For example, when testing upstream fish passage across technical fishways, it is

preferred to avoid invasive tagging or handling that may deter passage, but technical or economic limitations may make this unavoidable. Often, environmental monitoring is conducted using manual sampling techniques that are further studied in lab settings. The scope of this report is focused on improved testing of innovative technologies, so the focus of this section is on the instrumentation, although consideration of sampling practices is integral to environmental monitoring. Conventional examples of current hydropower-related environmental monitoring instrumentation and technologies used in lab and field settings include fish tagging and telemetry systems, hydroacoustic cameras, sediment tracers, dissolved oxygen sensors, and temperature sensors.

## APPENDIX B. EXAMPLE TEST FACILITY EVALUATION MATRIX

Initiative 2, described in Section 5.2.2, discusses the needs to establish one or more full-scale hydropower test facilities to help fulfill the hydropower testing needs described throughout this report. Section 6 proposes establishing these capabilities as federal testing centers that leverage existing federal water infrastructure. To further narrow the suitable sites for consideration, a science-based, objective evaluation approach is required.

To inform the selection, criteria that best meet the needs of the industry based on the broad review of hydropower testing and RFI were discussed in Section 5.2.2. The criteria were suggested considering (1) multiple projects with specialized capabilities may serve the same functions as one multi-objective facilities so criteria may differ, and (2) more information about testing equipment costs and performance tradeoffs are needed before prescribing specific test factor requirements. To further demonstrate how the evaluation matrix method can be used, this section provides an evaluation example based some prioritization weighting factors assigned by the authors. The prioritization weighting factors can be adjusted by decision makers based on specific needs and investment priorities.

The following evaluation method stems from a risk-based decision approach and applies several matrices to prioritize a set of evaluation criteria using weights and then score a set of alternatives. The first step of the process is to establish a set of criteria. Section 5.2.2 describes the rationale behind seven broad criteria categories, as summarized in Table B.1. These suggested criteria were informed by the review of hydropower testing and the RFI.

**Table B.1. Summary table of test facility evaluation criteria**

Index	Title	Description
A	Head capability	The maximum head condition, the availability of that head condition, and the range of head conditions that the facility can create.
B	Flow capability	The maximum flow condition, the availability of that flow condition, and the range of flow conditions that the facility can create.
C	Testing duration and availability	The maximum duration allowed for a given test, the number of tests that can be run simultaneously, and the temporal availability of testing.
D	Diversity of testing objectives and capabilities	The number of objectives that can be tested at the site and the breadth of test factors that can be applied.
E	Accessibility and regionality	The ability of personnel and equipment to easily access the site and how well the site represents development conditions.
F	Regulatory and operations impact	The likelihood of facility development success and the impacts of the added testing capabilities on existing operations/purposes.
G	Cost effectiveness	The costs to develop and maintain the facility, as well as the revenue potential of the project.

The next step is to prioritize these criteria. The prioritization process is conducted using a weighting matrix, as exemplified in Table B.2. As described in the table caption, the criteria (indexed by the letters from Table B.1) are compared in each intersecting row and column. The criterion with the higher priority is placed in the box (both are placed if equal) along with a weight factor (1 = equal importance, 2 = minor preference, 3 = medium preference, and 4 = major preference). The example values in Table B.2 are based on the reviews and RFI described in this report. The matrix outputs a list of weights that are used to scale the grades given to a facility for each criterion and compute a singular score. The example scale factors derived from Table B.2 are listed in Table B.3.

**Table B.2. Example criteria weighting matrix.** The letters refer to the criteria in Table B.1. The letter (criteria) with the highest priority from the respective row and column is placed in the corresponding box. If the priorities are equal, then each letter is placed in the box. The numbers refer to the weights where 1 = equal importance, 2 = minor preference, 3 = medium preference, and 4 = major preference

Weighting matrix	B		C		D		E		F		G	
A	A	2	A	2	A	2	A	2	A	2	A	2
B			B	1	B	1	B	1	B	1	B	3
C			C	1	D	1	E	1	F	1		
D					C	2	C	1			C	1
E							E	1	F	2	G	1
F							D	1			D	2
G							E	1	F	2		
											E	1
									F	2	G	1
											F	2

**Table B.3. Example weight factors for the test facility evaluation criteria**

Index	Criteria	Weight
A	Head capability	12
B	Flow capability	7
C	Testing duration and availability	5
D	Diversity of testing objectives and capabilities	4
E	Accessibility and regionality	4
F	Regulatory and operations impact	9
G	Cost Effectiveness	2

Finally, a grading system can be set to score a facility using a numeric value for each criterion. The example system in Table B.3 uses a 1 (least suitable) to 5 (most suitable) scoring method using the broad facility criteria and a mix of quantitative and qualitative descriptors for each grade. Some grades are inherently subjective, so it is up to the final funding agency (e.g., DOE) to define the grading requirements and assign the grades to candidate projects.

This grading system is used to apply grades to each criterion for a given facility. A final score for each facility is generated using the sum-product of the grades and weights for each criterion ( $i$ ), as illustrated in the following equation.

$$Score = \sum_i weight_i * grade_i$$

The final scores are useful metrics for comparing alternatives, particularly when the number of candidates is relatively high. Section 6 identified 190 candidate facilities using a high-level analysis with publicly available site data, and this evaluation matrix approach may be beneficial. However, complexities not captured in these criteria may affect the selected facilities. For example, if regionality is important to relevant stakeholders, selecting multiple regional or specialized facilities may be advantageous. Thus, it would be important for the final funding agency to evaluate how the testing objectives of multiple facilities synergize rather than purely selecting facilities with the highest scores. In addition, if the test facility initiative targets federal infrastructure, then the existing purposes of the infrastructure and the programmatic goals of the federal owners would play a major role and could prohibit development of existing sites despite high scores. Other considerations that could apply externally to this grading system include program budget, development timelines, state and local policies, and collaboration opportunities with other technology areas (e.g., hydrokinetic, wind, and solar).

Overall, this appendix provides an example methodology for evaluating the efficacy of candidate test facilities for meeting the testing needs identified in this report. This grading system can also provide insight to stakeholders who may propose a test facility project concerning the desired testing capabilities and design considerations. The proposed framework intends to provide an objective evaluation process to identify and prioritize suitable test facility sites for potential future investment.

**Table B.4. Example grading system for each test facility criteria**

<b>Grade</b>	<b>Head capability</b>	<b>Flow capability</b>	<b>Testing duration and availability</b>	<b>Diversity of testing objectives and capabilities</b>	<b>Accessibility and regionality</b>	<b>Regulatory and operations impact</b>	<b>Cost effectiveness</b>
<b>1</b>	<10 ft	<1,000 cfs capacity	Daily duration, low availability	None	Limited accessibility, far from representative development environments	Major constraints	High capital cost, no revenue potential
<b>2</b>	10–30 ft	1,000–3,000 cfs capacity, low availability	Daily duration, medium availability	1 standard capability	Moderate accessibility, far from representative development environments	Moderate to Major constraints	Moderate capital cost, moderate revenue potential
<b>3</b>	>30 ft, small head range, low availability	1,000–3,000 cfs capacity, high availability	Weekly duration, low availability	1–3 standard capabilities	Limited accessibility, close to representative development environments	Moderate constraints	High capital cost, high revenue potential
<b>4</b>	>30 ft, large head range, medium availability	>3,000 cfs capacity, medium availability	>Monthly duration, low availability	1–3 innovative capabilities	Moderate accessibility, close to representative development environments	Minor to Moderate constraints	Moderate capital cost, high revenue potential
<b>5</b>	>30 ft, large head range, high availability	>3,000 cfs capacity, high availability	>Monthly duration, high availability	3+ innovative capabilities	Great accessibility, close to representative development environments	None to Minor constraints	Low capital cost, high revenue potential



## APPENDIX C. SUMMARY OF RFI

### C.1 RFI: Testing Capabilities and Facilities to Validate Hydropower Technology Innovations

In August 2021, WPTO issued an RFI on the Energy Efficiency and Renewable Energy webpage (EERE T 540.111-02). The text of the RFI followed the structure of the present report, seeking “comments on the testing facilities and capabilities that will be needed by technology developers, manufacturers, designers, construction contractors, owners, regulators, researchers, and other stakeholders to validate and advance emerging and future hydropower technology (including pumped storage technology) and methodology innovations.”

The requested input was subdivided into four topics:

1. Emerging and future hydropower technology innovations, methodology innovations, and use cases (operating scenarios) that will need validation through testing
2. The current and future availability of and access to testing facilities and capabilities to meet the needs of emerging and future technology validation
3. The potential and challenges of federal water infrastructure being repurposed or co-purposed as testing facilities for emerging and future technology
4. The appropriate priorities, roles, and business models of federally funded hydropower test facilities.

The RFI questions submitted for public response are copied (and slightly edited to adapt the internal references) here directly from the WPTO RFI:

#### Topic 1: Hydropower Technology and Methodology Innovations in Need of Testing

DOE requests that respondents identify hydropower (including pumped storage) technology and methodology innovations that need testing, as well as the testing capabilities and methodologies that are needed. The question prompts included below are provided as a guide to respondents.

**Important:** *It is NOT necessary for respondents to answer all questions. Respondents need only identify their response as pertaining to Topic 1, answering only those questions they choose.*

The scope of Topic 1 includes technologies representing a range of TRLs, as well as conventional designs proposed for service in new operating regimes (increased start/stop and ramping, for example) and new ambient conditions (increased water temperatures and grey water conduits, for example). Testing of materials, parts, components, sub-systems, complete units, or even major portions of hydropower facilities are in scope for this RFI. Hybrid systems as such as hydropower with battery, pumps as turbines, and wind and pump storage technologies may also be considered.

Topic 1 also focuses on identifying and clarifying testing needs, including addressing the capabilities that do or do not exist for validating technological innovations against design objectives (Section 1.4). Examples of heretofore untested innovations and configurations include multi-pump arrangements in pumped storage designs, variable speed pump and generator testing, and advanced power electronics for grid interconnection.

**Question 1.1:** Does the hydropower technology landscape of Section 1.4 present a comprehensive framework for hydropower technology testing? Does it adequately address testing essential for commercialization? If not, what aspects are missing or incorrect?

**Question 1.2:** What are new and emerging technologies in need of testing? What is the footprint of these technologies and testing needs across the hydropower technology landscape of Section 1.4? Are the necessary testing capabilities (i) non-existent or (ii) existent but unavailable?

**Question 1.3:** Are there new operating regimes or new technology combinations (hybrid hydropower-battery designs, for example) that require new testing capabilities or facilities?

**Question 1.4:** What testing needs exist for testing and validating effective grid interconnection and the provision of services to the grid by hydropower assets? What are the challenges of doing so?

## **Topic 2: Availability of Hydropower Testing Facilities and Capabilities**

DOE requests that respondents comment on the *availability* of existing hydropower testing facilities and capabilities to address the technology testing needs scoped in Topic 1. The question prompts included below are provided as a guide to respondents.

**Important:** *It is NOT necessary for respondents to answer all questions. Respondents need only identify their response as pertaining to Topic 2, answering only those questions they choose.*

Facilities in this case includes those hosted and operated by commercial providers, academic institutions, DOE laboratories, and other federal agency laboratories. Testing that is possible at federal water infrastructure (having a primary purpose other than testing and experimentation) is addressed in Topic 3.

DOE is interested in the challenges that those with testing needs face when searching for and engaging with these facilities. Challenges may include funding of testing expenses, contracting, scheduling of short- and long-term testing amidst multiple clients, and confidentiality of test articles and results. DOE is also interested in the comparative value and difficulty of testing technology at a single integrated facility versus a network of facilities with different, but complementary, testing capabilities.

**Question 2.1:** What is your experience with hydropower technology testing? Please identify the testing facilities you have accessed and the test outcomes you obtained. What challenges did you face in accessing these facilities and achieving outcomes?

**Question 2.2:** Are centralized multi-capable facilities a necessity for your development pathway or can dispersed testing facilities generally meet your requirements/expectations? How can facilities be coordinated efficiently to facilitate access to and cooperation among hydropower technology developers and stakeholders?

**Question 2.3:** Considering the hydropower technology landscape introduced in Topic 1, what gaps in testing availability are limiting your progress or industry progress?

**Question 2.4:** How adaptable are existing facilities to future hydropower needs (for example, solar-wind-hydropower hybrid technology, pumped storage technology, hydropower-battery hybrid technology, turbine aeration, or fish passage technology)?

### **Topic 3: Suitability and Availability of Federal Water Infrastructure to Support Hydropower Technology Testing**

The third topic of this RFI is the potential repurposing or co-purposing of federal water infrastructure for testing hydropower technologies. In this context, federal water infrastructure is defined as engineered facilities having a primary purpose other than testing and experimentation—dams (powered and non-powered), navigation locks, irrigation systems, and other federal water control facilities. Using federal water infrastructure for testing would leverage prior federal funding for development and operation facilities and may be less expensive than capital investments required for a new federal testing facility for hydropower technology. The question prompts included below are provided as a guide to respondents.

**Important:** *It is NOT necessary for respondents to answer all questions. Respondents need only identify their response as pertaining to Topic 3, answering only those questions they choose.*

The compatibility of such facilities will need evaluated to ensure existing mission objectives continue to be accomplished or, in the case of decommissioned facilities, ensuring that they can be restored to service with appropriate testing capabilities. Such repurposing or co-purposing of federal infrastructure would be a federal action and require environmental assessment and public input compliant with NEPA regulations. Ownership, control, liability, and regulatory jurisdictions for infrastructure, testing equipment, test articles, and operations are issues that will require further study (Topic 4 addresses business models for hydropower technology testing facilities).

Desirable features of federal water infrastructure for hydropower technology testing include abundant and predictable water availability, sufficient hydraulic head, flexibility to vary upstream and downstream water levels for testing, and the ability to accommodate a range of fluctuating and varied power inputs and outputs for testing. The interconnection of power to existing transmission or distribution systems will need explored of non-powered (non-generating) infrastructure. The addition of hydropower generation to existing USACE navigation and fishway facilities may provide insight into how new mission objectives can be combined with existing operations at federal facilities.

**Question 3.1:** Are you aware of federal water infrastructure that may be useful in testing hydropower technology? If so, please describe the facility and its desirable and unique features.

**Question 3.2:** What factors should DOE consider (for example, necessary modifications or upgrades, interconnections, water management, environmental assessment, regulatory jurisdiction) in selecting, conceptualizing, designing, and implementing hydropower technology testing at a federal water infrastructure facility?

**Question 3.3:** How would scheduling and testing needs best be coordinated between the primary mission and the testing mission of the infrastructure/facility?

### **Topic 4: Priorities, Roles, Business Models, and Access for DOE-Sponsored Hydropower Test Facilities**

The business model for a hydropower test facility, or a network of facilities, must describe the rationale, in terms of use cases, costs, and benefits, for creating and operating the facility to deliver value to stakeholders and the public. Use cases for a new test facility must be consistent with prioritized unmet needs for hydropower technology testing (i.e., those parts of the technology-objective matrix for which testing capabilities or access to capabilities are insufficient). Consistent with these defined use cases, the business model must address public and commercial benefits of the facility; costs of development,

operation, and maintenance of the facility; estimation of the initial and ongoing demand for testing services; estimation of capital and financial income to the facility from public and commercial sources; and timelines and lifetime for the facility. The question prompts included below are provided as a guide to respondents.

**Important:** *It is NOT necessary for respondents to answer all questions. Respondents need only identify their response as pertaining to Topic 4, answering only those questions they choose.*

Institutional roles for ownership, control, operation, outreach, and technical support will influence the business model for the test facility, as will the river system, power system, and regulatory contexts for the facility. In particular, DOE must discern and define its role within the hydropower test facility activities, which may include selecting users and enabling user access, assessing and ensuring efficacy of testing through best practices and standards development, coordinating testing at the facility with testing external to the facility, and providing technical support and subject matter expertise to the facility.

**Question 4.1:** What metrics and rubrics should DOE use to prioritize testing needs that are unmet by existing testing facilities and capabilities?

**Question 4.2:** What factors (value proposition) do technology developers consider in decisions to engage a facility to test their hydropower technology?

**Question 4.3:** How can DOE ensure that hydropower technology testing facilities are available to many different users for many different needs?

**Question 4.4:** How should DOE sequence the development of a test facility (e.g., specification, site selection, conceptual design, environmental assessment, engineering design, construction/installation, commissioning, operation, decommissioning) to maximize the value of a public investment in hydropower technology testing facilities?

## **Topic 5: General Comments**

**Question 5.1:** What other information about hydropower technology and methodology innovation testing is important for DOE to know in planning and implementing hydropower R&D?

## **C.2 List of Respondents**

The respondents to the RFI included private and national laboratories, universities, hydropower developers and consultants, federal agencies, and foundations sponsoring hydropower.

The full list of respondents is as follows:

- Alden Research Laboratory
- Cadens LLC
- ERDC (USACE)
- Hydropower Foundation
- Mark McKinley
- Natel Energy
- NHA
- PNNL
- St. Anthony Falls Laboratory (University of Minnesota)

- TVA
- Tetramer Technologies
- University of California, Davis
- Willow Springs Water Bank

### C.3 RFI Key Takeaways

Takeaway	Where is addressed in the report
There is significant testing infrastructure at universities and national laboratories to conduct early stage technology testing, but more infrastructure is needed for full-scale mid-to-late stage testing.	Section 3.2, Theme 1
“Virtual” or distributed testing capabilities can facilitate in situ testing.	Section 3.2, Themes 2, 3, and 4
There is investment and interest in hydropower and pumped storage designs that leverage alternative water systems, such as urban water distribution systems, canals, and aquifers.	Section 2.2, Section 2.3, and Section 3
New hydropower infrastructure can facilitate colocation of energy resources such as electric vehicle charging, wind, and solar.	Outside the scope of this report
A testing network approach may help leverage existing testing capabilities.	Section 3.2 and Initiative 1 in Section 5
Improved testing comes with a need to improve testing standards and educate stakeholders about accepted standards.	Section 2, Section 3.2 Themes 2 and 3, and Section 5
Funding mechanisms, including the acceptance of risk during the financing/insuring processes, are helpful for promoting testing and development within the industry.	Section 3.2 and Initiative 1 in Section 5
New federal testing infrastructure may compete directly or indirectly with private providers, so the relationship with industry must be considered. However, federal infrastructure also provides the opportunity to build relationships with other stakeholders, such as the hydropower workforce, regulators, students, and universities.	Section 3.2, Initiative 1 in Section 5, and Section 6
The duration, availability, accessibility, and security of testing capabilities must be considered.	Section 3.2, Theme 3
Regional locations/capabilities would facilitate environmental testing in different ecosystems.	Section 3.2, Themes 1 and 2
Federal testing should help inform regulatory requirements and support conversations between stakeholders and regulators.	Section 5
Control of the environmental and hydraulic conditions is critical to the scope of testing capabilities.	Section 3.2, Themes 2 and 3

### C.4 Mentioned Technologies

- Variable frequency/speed technologies
- Permanent magnet generators and smart inverters for hydropower
- Small/micro turbines and pumps-as-turbines
- Artificial intelligence and adaptive management for improved operation
- Nano-bubble and aeration technologies
- Fish passage/exclusion technologies and fish-safe turbines
- Low-head pumped storage, hydropower turbines, and current energy converters
- Modular hydropower technologies
- Environmentally acceptable lubricants

## APPENDIX D. REVIEWER GENERAL COMMENTS AND RESPONSES

This appendix reports a list of the major comments raised by reviewers followed by the authors' relative responses. The names of reviewers are omitted to respect anonymity. The original comment is presented in italics followed by the authors' response in regular text. All the other editorial comments and content/structure improvement suggestions were implemented directly in the text and are not reported in this appendix.

### Reviewer #1

- *Lots of mention of validation of technologies and approaches, which is important, but we should also add demonstration of novel ideas. Demonstration and validation of hydropower technologies will be consistent with the terminologies used in other WPTO projects (e.g., Vision) and by industry (e.g., NHA's Waterpower Innovations Council)*

We do agree that demonstration is as important as validation of innovative components. However, demonstration targets TRLs 8 and 9 might be outside the scope of the report, which focuses more on the opportunities for testing (more mid-range TRLs.) We included some brief discussion under Initiative 1 (Section 5.2.1), where we stated, "Such a program should also consider whether support should be limited to technology development or whether site deployment could also be supported." Considering the reviewer's comment, we now added new language under Criterion G in Section 5.2.2, addressing this particular suggestions and other potential ancillary services that a new testing facility could provide. It is ultimately up to the final funding agency (e.g., DOE) to decide the extent of the investment and the potential program.

- *It is clear from the main report that the hydropower facility investment is focused on small hydropower development and not rehabilitation and retrofits of existing facilities, but that could be clearer in the Executive Summary.*

The focus of the report is on small hydropower developments intended as size of the project (head and flow), namely as a general characteristic, which includes new development as well as rehabilitation and retrofits. In fact, the premise of the report and the requirements/dimensions indicated for a potential full-scale testing facility are based on the trend of future hydropower development that will target low-head sites "from NSDs, NPD retrofits, and upgrades of the existing fleet" (Section 5.1). We indicate this in Sections 1.3.1 and 5.1. Considering the reviewer's comment, we added this specification in the Executive Summary, as well.

- *Additional detail for types of facilities that are needed for the hydropower testing network program would be helpful in the Executive Summary.*

The testing network program described in Initiative 1 is proposing to coordinate existing testing facilities (described more in Section 4.1). The Executive Summary should not include detailed information; however, we now specify that the existing facilities to be coordinated are highlighted in the report: national laboratories, universities, private testing centers, and federal agencies.

- *It's not clear who the audience for this report is. It is very detailed in some places and vague in others. In some of the places that attempt to provide a comprehensive review, things fall short. I'll pick on the environmental mitigation section that appears pretty lopsided.*

We recognize that some descriptions are more detailed than others. However, we believe that the technological areas where we added more discussion are indicative of more active research and emerging technologies.

Regarding the audience, as indicated in Section 1.1, the main audience/receiver of this report is WPTO. However, the report is intended to be a tool to receive and reflect/summarize feedback from the public (i.e., the hydropower stakeholders, including developers, owners, and researchers). Therefore, the same hydropower stakeholders who provided the initial feedback are also part of the audience. Considering the reviewer's comment, this is now clarified in Section 1.1 as follows: "Ultimately, the report reflects and summarizes feedback from hydropower stakeholders (e.g., developers, owners, researchers), which are therefore contributors and beneficiaries (i.e., part of the audience)."

## **Reviewer #2**

- *It appears that the testing needs (throughout the documents) summarized within the report are mainly based on high level and technical reports/publications. It is not clear if these testing needs have been verified by all parties interested in using the testing facilities (e.g., federal entities, private operators, OEMs, small companies that are not part of CEATI).*

This is a very good point. However, the conclusions were elaborated through both literature review and an RFI. The RFI was sent out to a diverse set of hydropower stakeholders, including academia, national labs, private organizations, federal agencies, plant owners and hydropower developers. The list of respondents and a summary of the responses is provided in Appendix C. Some of the responses indicated that "more infrastructure is needed for full-scale mid-to-late stage testing," whereas others indicated that "a testing network approach may help leverage existing testing capabilities."

## **Reviewer #3**

*USBR projects are authorized for specific purpose(s)—delivering benefits to customer and stakeholder groups across the western United States. Specifically, Reclamation project customers (e.g., water and power customers) collectively fund USBR project operations and maintenance activities, investments, original construction costs, and so on. Given current authorities, USBR is not authorized to repurpose federal, USBR projects or existing federal, USBR project works (e.g., federal, USBR hydropower facilities) for testing facility purposes—which the report implicitly recommends. USBR would not begin exploring this option without first coordinating with our customers, stakeholders, operating partners, and so on.*

*In all cases, USBR would not alter USBR project operations in a way that conflicted with authorized USBR project purposes, associated contracts, and related commitments.*

*With that said, opportunities may exist for the development of nonfederal testing facilities on USBR projects, provided all required authorizations are in place (which would require the nonfederal testing facility operate in harmony with the underlying USBR project).*

This is an extremely important point and we thank the reviewer for making this clarification. The comment refers to USBR projects, but we assume that this might be applicable to other federal facilities, as well, such as USACE. To address this point, we included clarifying text in Section 6.1, specifically: "In particular, USBR and USACE are not authorized to repurpose existing projects without first coordinating with the customers, operating partners, and other stakeholders that the project serves. Per Criterion F, the testing retrofit must not interfere with authorized purposes and existing operations.

Opportunities may exist to retrofit federal after consultation processes or as the authorized purposes change over time, so these USACE and USBR facilities were not excluded from the following analysis.”

- *I'm seeing references to testing of cybersecurity testing and novel instrumentation for hydropower systems, but is there any interest in the testing of data infrastructure solutions, models, algorithms, and related data tools in support of more proactive monitoring and diagnostics of hydropower assets?*

Proactive monitoring is technically covered under digital twin in Section 2.5. We are now adding the word *proactive* to the digital twin paragraph in Section 2.5.1.6 and a brief disclaimer paragraph to in Section 2 as follows: “The validation of models, algorithms, and related data tools is inherent in the testing of hydropower technologies. These data solutions are part of the prototyping processes as they predict and assess the performance of technologies during operation. This report focuses on physical testing capabilities toward the goal of identifying unmet testing that can be met with new testing infrastructure. Although not explicitly addressed in all the following sections, data and modeling efforts are a key piece of testing practice and should be considered as part of any proposed initiatives (Section 5).”

- *Climate change is noted on p. 23—climate change and drought (generally, changes in water availability) are additional, potential drivers for industry innovation.*

We added a clarifying sentence in Section 1.3.1 as follows: “particularly within the context of climate change, which is expected to alter water availability and variability.”

#### **Reviewer #4**

- *It may not fit within the boundaries of this report, but in addition, or as an alternative, to financing the construction of a full-scale test facility, it may be wise to suggest financing of a few field demonstration projects (deployments of actual small hydropower projects using new techniques or technology) that can be analyzed and benchmarked and provide proof of concept and proof of economics for future similar projects.*

Demonstration programs could also be very important and might align with the investments suggested in this report, but it is indeed out of the scope. This comment align with the first comment of Reviewer #1, so we refer the reader to that response. In particular, we added content under Criterion G in Section 5.2.2 to address this particular suggestions and other potential ancillary services that a new testing facility could provide. It is ultimately up to the final funding agency (e.g., DOE) to decide the extent of the investment and the potential program.

#### **Reviewer #5**

- *One of the main constraints on powering up NPDs is the civil works challenge.*

This is an important and very relevant observation. We added some language in Section 1.3.1 where we first introduced the constraints surrounding NPDs retrofit, and specifically: “Civil works necessary for the retrofit might be a serious challenge and structural safety will be a major concern, so innovative modular designs, advanced manufacturing, and alternative materials are needed to safely integrate new technologies and rehabilitate existing infrastructure. These innovations will require testing for the reliability/stability of the technology and the existing infrastructure. In addition, new technologies may require new ways to deploy the technology, which requires testing for the H&S of people during deployment.” We also discuss the opportunities associated with NPDs retrofit throughout Section 2 and in



particular when discussing emerging technologies for conveyances (Section 2.2.1) and structures (Section 2.3.1). Most of the opportunities associated with the civil works challenges could likely be addressed with the use of advanced manufacturing, which falls under Theme 4. In this regard, we added to Theme 4 the sentence, “Advanced materials and manufacturing could also help address the civil works challenge, which might undermine future NPDs retrofit projects.”

- *Initiative 1 utilizes existing expertise and assets while Initiative 2 builds a new facility. What crossover might there be? Perhaps a good program would be to partner with the Initiative 1 staff to have a hand in developing and operating the proposed new facility. Maybe a fellowship program where people can spend a couple years at the facility.*

Considering the reviewer’s comment, we added the following language in Section 5.2.1 under Initiative 1: “A testing program would facilitate the collaboration with and among private facilities, federal agencies and infrastructure, universities, national laboratories, and any federal testing centers proposed in Initiative 2. Potential collaboration examples include conferences, tours, and fellowships programs to educate and train future workforce.” The idea of workforce education is very interesting and relevant and it is also reiterated in the next comment; therefore, please refer to the next comment’s response for this comment, as well.

- *Not a lot of focus on workforce development. Could focus more on how the new center might be staffed to spread skills throughout the industry.*

Considering the reviewer’s comment, we added the following language in Section 5.5.2.2 under Initiative 2, Criterion G: “In addition, several other features could promote the value of the test facility outside of the envelope described by these criteria. For example, the test facility could serve as a hub for hydropower workforce development through education or training rotation programs for students and industry professionals. The test facility could also facilitate industry engagement and the dissemination of research through conferences, events, and or business incubation programs.”

- *Innovation ecosystem development. Could think through more clearly how the ecosystem of startups might coalesce around the new center. How would they feel comfortable about IP? Would they collaborate with each other, or just with the center? How would the center tie in with any nearby DOE labs? With the dam operator?*

This is a very interesting point and the reviewer raises important questions. However, it might be up to the final funding agency (e.g., DOE) and the selected stakeholder to answer to these questions. Considering the reviewer’s comment, we added the following language in Section 5.5.2.2 under Initiative 2, Criterion G: “The test facility could also facilitate industry engagement and the dissemination of research through conferences, events, and or business incubation programs. Coordination and development of these programs will depend on the guidance of WPTO and the stakeholders selected to design, own, and operate the test facility. The following section makes the case for developing the test facility at an existing federal facility, because it is expected to have the lowest cost and timeline for meeting the testing needs captured in this report. Although, other options exist for the development of these testing capabilities including construction of a greenfield facility, investment in field demonstration projects, expansion of existing laboratory facilities, and mobile testing infrastructure. The implementation of this initiative will depend on the strategic goals of WPTO as they relate to meeting the testing needs of the hydropower industry.

